

LOC		DIST		REVISIONS			
GP	00	REV	DATE	BY	CHK	APPV	
Z		REVISED PER ECO-06-010443	28AUG	JRP	SB		
Z1		REVISED PER ECO-09-021826	07JAN10	KK	AEG		

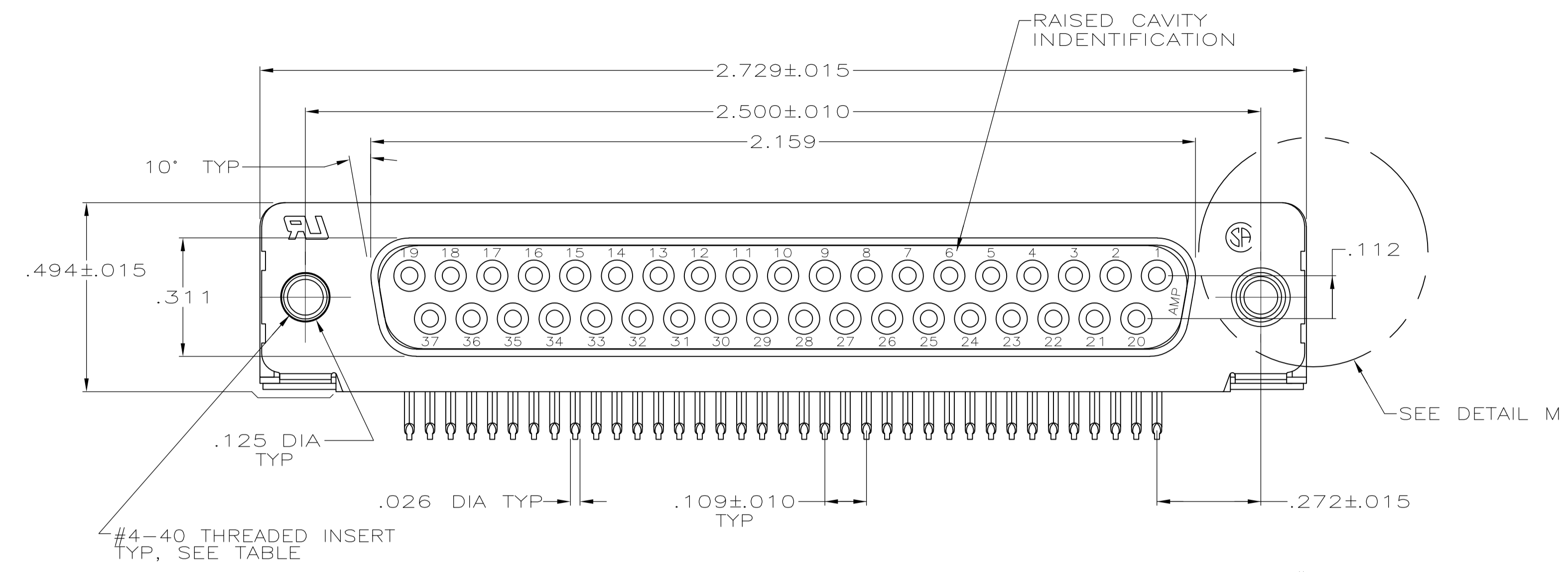

1. CONNECTOR MATES WITH ANY 37 POSN PLUG IN AMPLIMITE™ SERIES & COMPLIES WITH AMP SPEC 108-40005 WHERE APPLICABLE.
2. MOLDED PARTS: FLAME RETARDANT 94V-0 RATED THERMOPLASTIC, BLACK.  
SHELL: STEEL PER ASTM A109  
CONTACTS: PHOSPHOR BRONZE PER QQ-B-750  
EYELETS: BRASS  
SCREWLOCKS: ZINC  
INSERTS: ZINC
3. SHELL: TIN PLATED  
CONTACTS: SEE TABLE  
EYELETS: TIN PLATED  
SCREWLOCKS: CLEAR CHROMATE  
INSERTS: CLEAR CHROMATE
4. GOLD PLATING PER MIL-G-45204, NICKEL PLATING PER QQ-N-290, TIN PER MIL-T-10727.
5. GOLD FLASH FOR A DISTANCE OF .100 MIN FROM MATING END, TIN PLATED .000100-.000200 ON OPPOSITE END, ALL OVER .000050 NICKEL.
6. .000030 GOLD FOR A DISTANCE OF .100 MIN FROM MATING END, TIN PLATED .000100-.000200 ON OPPOSITE END, ALL OVER .000050 NICKEL.
7. .000015 MIN GOLD FOR A DISTANCE OF .100 MIN FROM MATING END, TIN PLATED .000100-.000200 ON OPPOSITE END, ALL OVER .000030 NICKEL.
8. OBSOLETE PARTS: OBSOLETE CIS STREAMLINING PER D.RENAUD/D.SINISI

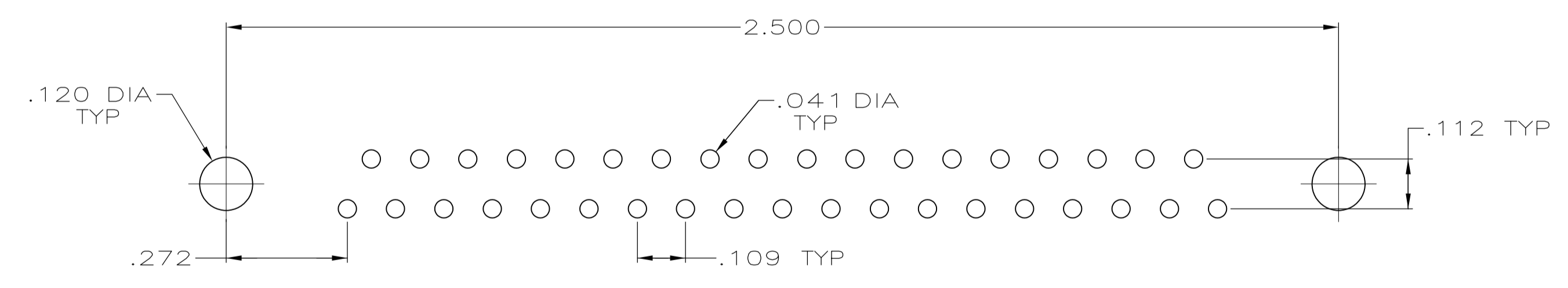
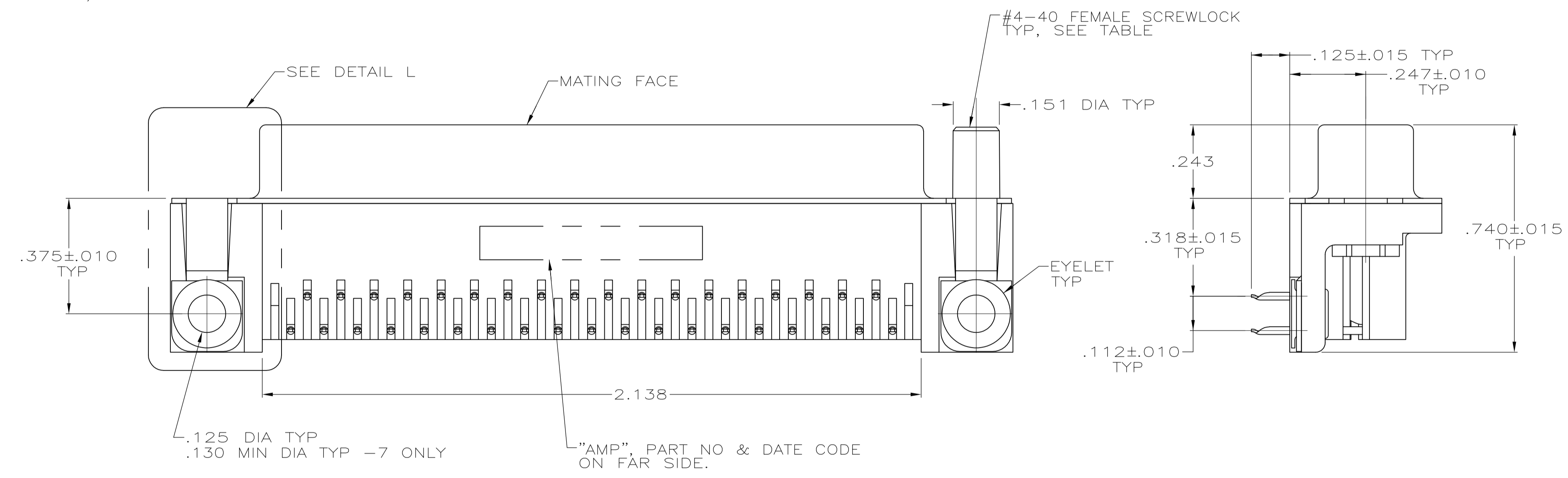

PC BOARD MOUNTING DIMENSIONS

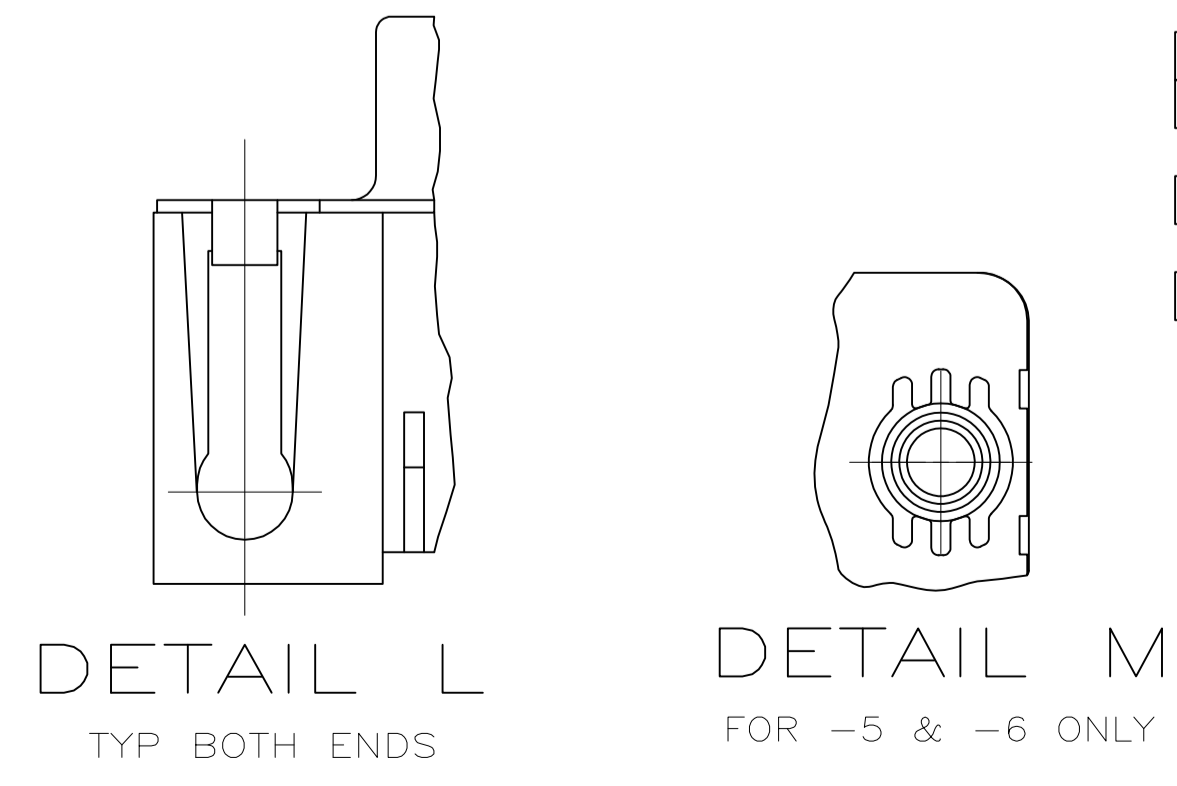

OBSOLETE	FEMALE SCREWLOCKS	CLINCH TABS (SEE DETAIL L)	6	1-745784-3
OBSOLETE	FEMALE SCREWLOCKS	CLINCH TABS (SEE DETAIL L)	5	1-745784-2
OBSOLETE	THREADED INSERTS	CLINCH TABS (SEE DETAIL L)	6	1-745784-1
OBSOLETE	THREADED INSERTS	CLINCH TABS (SEE DETAIL L)	5	1-745784-0
OBSOLETE	.125 DIA HOLE	CLINCH TABS (SEE DETAIL L)	6	745784-9
OBSOLETE	.125 DIA HOLE	CLINCH TABS (SEE DETAIL L)	5	745784-8
OBSOLETE	NONE	GROUNDING STRAPS	7	745784-7
SUPSD BY 5745784-6	FEMALE SCREWLOCKS	GROUNDING STRAPS	6	745784-6
SUPSD BY 5745784-6	FEMALE SCREWLOCKS	GROUNDING STRAPS	5	745784-5
SUPSD BY 745784-4	THREADED INSERTS	GROUNDING STRAPS	6	745784-4
SUPSD BY 745784-4	THREADED INSERTS	GROUNDING STRAPS	5	745784-3
OBSOLETE	NONE	GROUNDING STRAPS	6	745784-2
SUPSD BY 745784-4	NONE	GROUNDING STRAPS	5	745784-1

MOUNTING HARDWARE	SHELL VERSION	CONTACT FINISH	PART NUMBER
		4	

THIS DRAWING IS A CONTROLLED DOCUMENT.

DIMENSIONS: INCHES	TOLERANCES UNLESS OTHERWISE SPECIFIED:	DIN J GALLUCCI BG 1-23-91	tyco Electronics	Tyco Electronics Corporation Harrisburg, PA 17105-3608
0. PLC ± -	1. PLC ± -	CHK R. STONE 4-26-91	NAME	RCPT ASSY, SIZE 4, 37 POSN, RTANG, AMPLIMITE HD-20, WITH METAL SHELL, WITH OR WITHOUT SCREWLOCKS OR INSERTS
2. PLC ± -	3. PLC ± .005	APVD	PRODUCT SPEC	108-40025
4. PLC ± -	ANGLES ± -		APPLICATION SPEC	114-40010
MATERIAL	FINISH	WEIGHT	SIZE	CAGE CODE
			A1	00779
			DRAWING NO	745784
			RESTRICTED TO	
			CUSTOMER DRAWING	SCALE 4:1 SHEET 1 OF 1 REV Z1