



# RJ45 Integrated Connector

10 Base-T, Single Port, Through Hole, LEDs, Tap-up

MODEL NUMBER  
**TIC-L052-11**

- Meets IEEE 802.3 and ANSI X3.263
- Operating temperature: -40°C to +85°C
- Storage Temperature: -40°C to +85°C

Package Information			
Weight		Quantity	
weight/pcs (g)	weight/carton (kg)	quantity/tray (pcs)	quantity/carton (pcs)
7.2	3.4	50	250

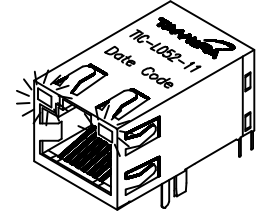

Electrical Specification @ 25°C						
Insertion Loss (dB Max)	Return Loss (dB Min)	CMRR (dB Min)	Crosstalk (dB Min)	OCL (μH Min)		Hipot (Vrms)
1-10 MHz	1-10 MHz	1-100 MHz	1-10 MHz	100KHz		1 minute
				(2-3)	(4-5)	
-1	-18	-30	-40	45	230	1500
						100

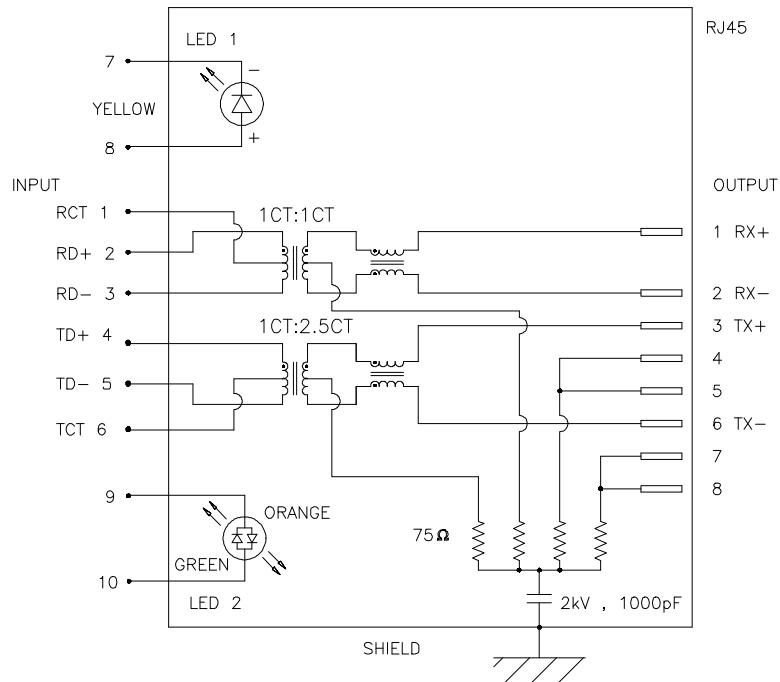

PREPARED BY:

D. Rund

ENGINEER:

L. Le

QUALITY CONTROL:

D. Kelley

APPROVED:

J. Coleman

DWG CONTROL NO.  
P-A1-13067  
ACAD\TIC\A1130671.DWG

REV  
PRE

RJ45  
INTEGRATED CONNECTOR

**TAMURA CORPORATION OF AMERICA**  
43352 BUSINESS PARK DRIVE, TEMECULA, CA. 92590-6624  
(909) 699-1270 FAX 9096769482

**TIC-L052-11**  
MODEL SPECIFICATION

DIM: mm(In) SCL: NONE SH: 1 OF 2

PROPRIETARY NOTICE: THIS DRAWING PRINT OR DOCUMENT AND SUBJECT MATTER DISCLOSED HEREIN ARE PROPRIETARY ITEMS TO WHICH TAMURA RETAINS THE EXCLUSIVE RIGHT OF DISSEMINATION, REPRODUCTION, MANUFACTURE AND SALE. THIS DRAWING, PRINT OR DOCUMENT IS SUBMITTED IN CONFIDENCE FOR CONSIDERATION BY THE RECIPIENT ALONE UNLESS PERMISSION FOR FURTHER DISCLOSURE IS EXPRESSLY GRANTED IN WRITING.



# RJ45 Integrated Connector

10 Base-T, Single Port, Through Hole, LEDs, Tap-up

MODEL NUMBER  
**TIC-L052-11**

Mechanical Material Specification									
Contact							Plastic Part		Shell
RJ Contact				RJ and LED Joint Contact			RJ Housing	Set Housing & Spacer Insert	Back
Contact Material	Contact Area	Solder Tail Area	Under-plating	Contact Material	Finish	Under-plating			
Phosphor Bronze	Gold	Tin/Lead (9:1)	Nickel	Brass	Tin/Lead (9:1)	Nickel	Thermoplastic, PC, Transparent	Thermoplastic PA6T, Black	Stainless SUS 304-1/2H
0.30 mm thick	30 μ" Min.	100 μ" Min.	50 μ" Min.	0.30mm thick	100 μ" Min.	50 μ" Min.	UL 94V-0	UL 94V-0	0.20 mm thick

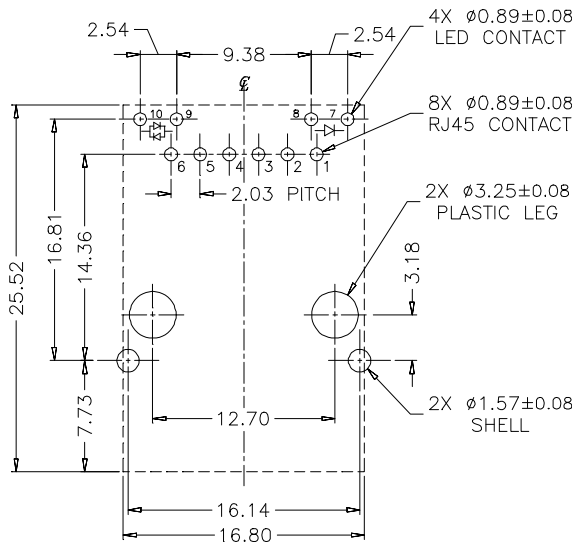

RECOMMENDED PCB LAYOUT  
COMPONENT SIDE  
PCB THICKNESS : 1.60mm  
ALL DIMENSION TOLERANCE ARE ±0.05  
UNLESS OTHERWISE SPECIFIED

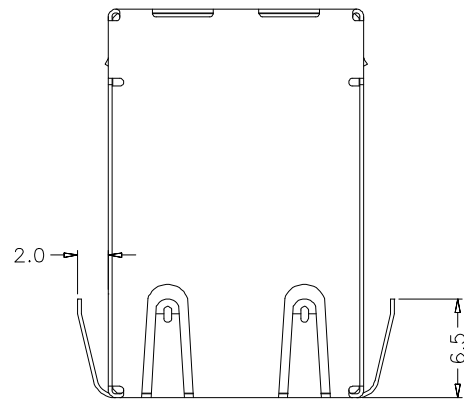

GENERAL TOLERANCE  
.XX ±0.13  
.X ±0.25

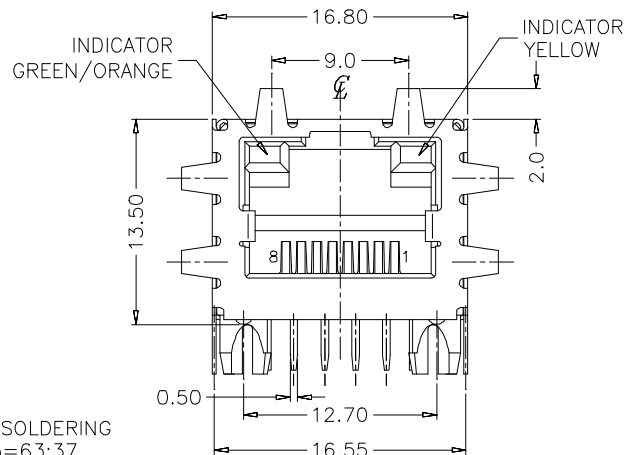
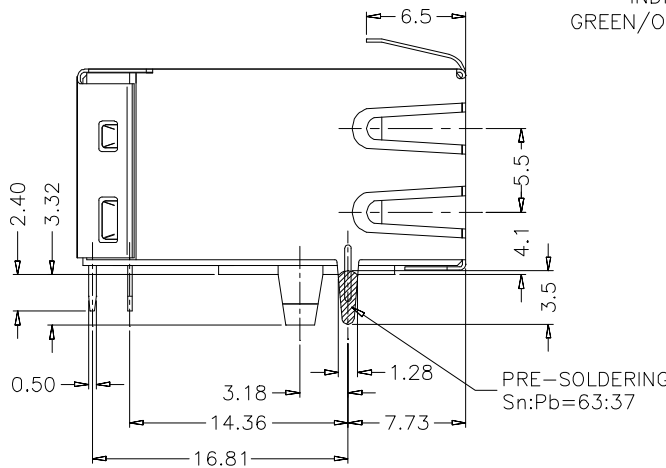

PREPARED BY:

D. Rund

ENGINEER:

L. Le

QUALITY CONTROL:

D. Kelley

APPROVED:

J. Coleman

DWG CONTROL NO.  
P-A1-13067  
ACAD\TTC\A1130672.DWG

REV  
PRE

RJ45  
INTEGRATED CONNECTOR

**TAMURA CORPORATION OF AMERICA**  
43352 BUSINESS PARK DRIVE, TEMECULA, CA. 92590-6624  
(909) 699-1270 FAX 9096769482

**TIC-L052-11**

MODEL SPECIFICATION

DIM: mm(In) SCL: NONE SH: 2 OF 2

PROPRIETARY NOTICE: THIS DRAWING PRINT OR DOCUMENT AND SUBJECT MATTER DISCLOSED HEREIN ARE PROPRIETARY ITEMS TO WHICH TAMURA RETAINS THE EXCLUSIVE RIGHT OF DISSEMINATION, REPRODUCTION, MANUFACTURE AND SALE. THIS DRAWING, PRINT OR DOCUMENT IS SUBMITTED IN CONFIDENCE FOR CONSIDERATION BY THE RECIPIENT ALONE UNLESS PERMISSION FOR FURTHER DISCLOSURE IS EXPRESSLY GRANTED IN WRITING.