

CUSTOMER HOTLINE 1 800 722-1111

REDUCED FOR PACKAGING

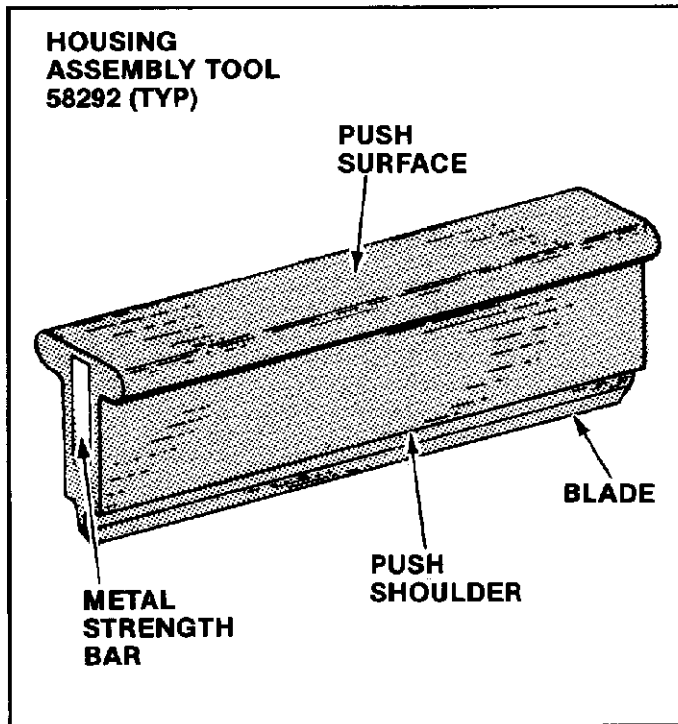

**Fig. 1**

## 1. INTRODUCTION

AMP Housing Assembly Tool with base number 58292 is designed to aid in the assembly of AMP PACE\* and ECONOMATE\* I connector housings to printed circuit (pc) boards and panels. The dash numbers of the tool designate the number of dual contact positions and the centerline size (.100, .125, and .156) of the connector. Each tool is designed for specific connector housings and should only be used to assemble housings specified in Figure 5. Read these instructions carefully before using the tool.

**NOTE** All dimensions on this sheet are in inches.

## 2. DESCRIPTION (Figure 1)

The tool, which is used in conjunction with a suitable manual applicator assembly, is a one-piece plastic device with an integral metal strength bar. The blade of the tool fits into the center of the connector card slot, and the push shoulders of the tool rest on the upper surfaces of the connector housing. The pressure of the machine ram on the push surface of the tool completes the assembly of the housing to AMP ACTION PIN\* contacts inserted in the pc board or panel.

## 3. APPLICATION PROCEDURE

Using a suitable work station which includes a board support fixture to protect the ACTION PIN contact posts during the assembly process, proceed as follows:

1. Ensure that proper housing and housing assembly tool are selected.

**CAUTION** Use of improper tool or housing will result in damage to housing and contacts.

2. Place AMP PACE or ECONOMATE I connector housing loosely over corresponding ACTION PIN contacts already installed in pc board or panel. See Figure 2.

**CAUTION** Do NOT press housing onto contacts without using housing assembly tool.

3. Ensure that contacts are not stubbed on housing and are fitted into correct contact positions in housing.

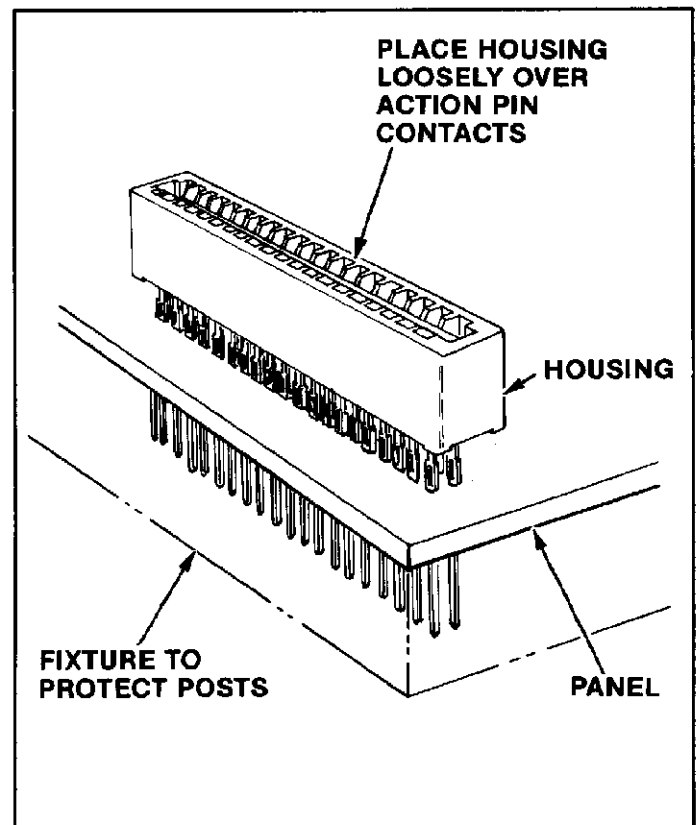

**Fig. 2**

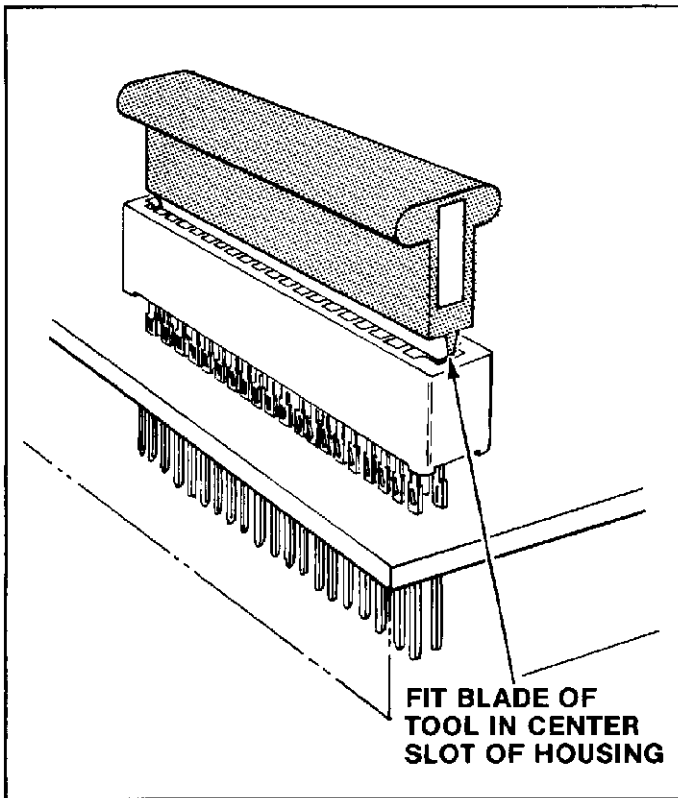

Fig. 3

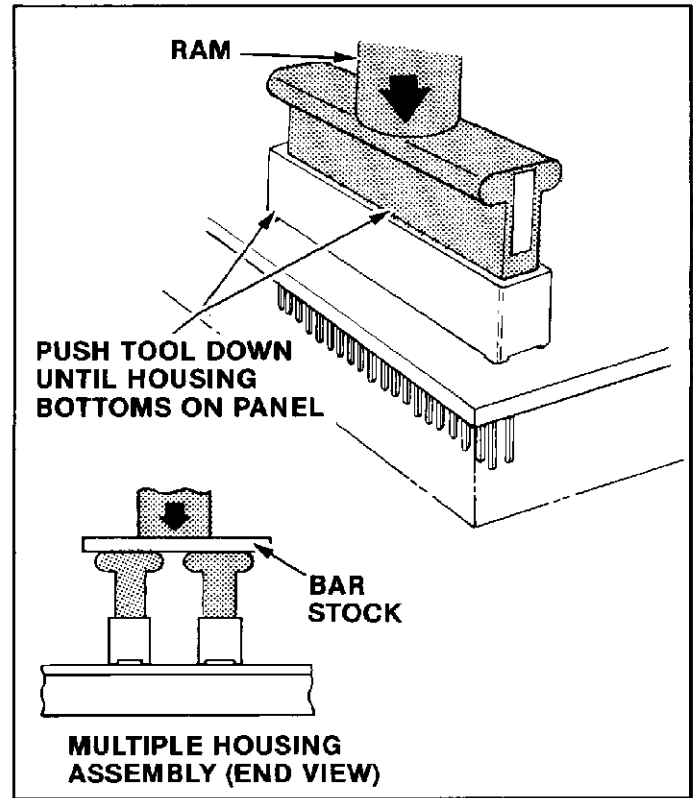

Fig. 4

4. Fit blade of housing tool into center of housing card slot (Figure 3).
5. Position pc board or panel so that assembled tool and housing are centered under the machine ram.
6. Apply pressure (approximately 6 lb per dual contact position) to push surface of housing tool by lowering ram until housing bottoms on pc board or panel. See Figure 4.

**NOTE** *Two or more connector housings can be assembled simultaneously by using additional housing assembly tools and a piece of bar stock to distribute the pressure of the machine ram. Refer to Figure 4.*

7. Retract machine ram and carefully remove housing tool by lifting straight out of connector card slot.

This completes the application procedure. Examine installed housing carefully for any damaged contacts before returning the pc board or panel to service.

**4. MAINTENANCE**

Little maintenance is required for the tools other than to ensure that they have not become worn or damaged through use. Tools should conform to the dimensions shown in Figure 5. Tools that have become worn or damaged should be replaced. For additional tools, contact your local AMP representative or send a request to

AMP Incorporated  
 P.O. Box 3608  
 Harrisburg, PA 17105-3608

or a wholly-owned subsidiary of AMP Incorporated.

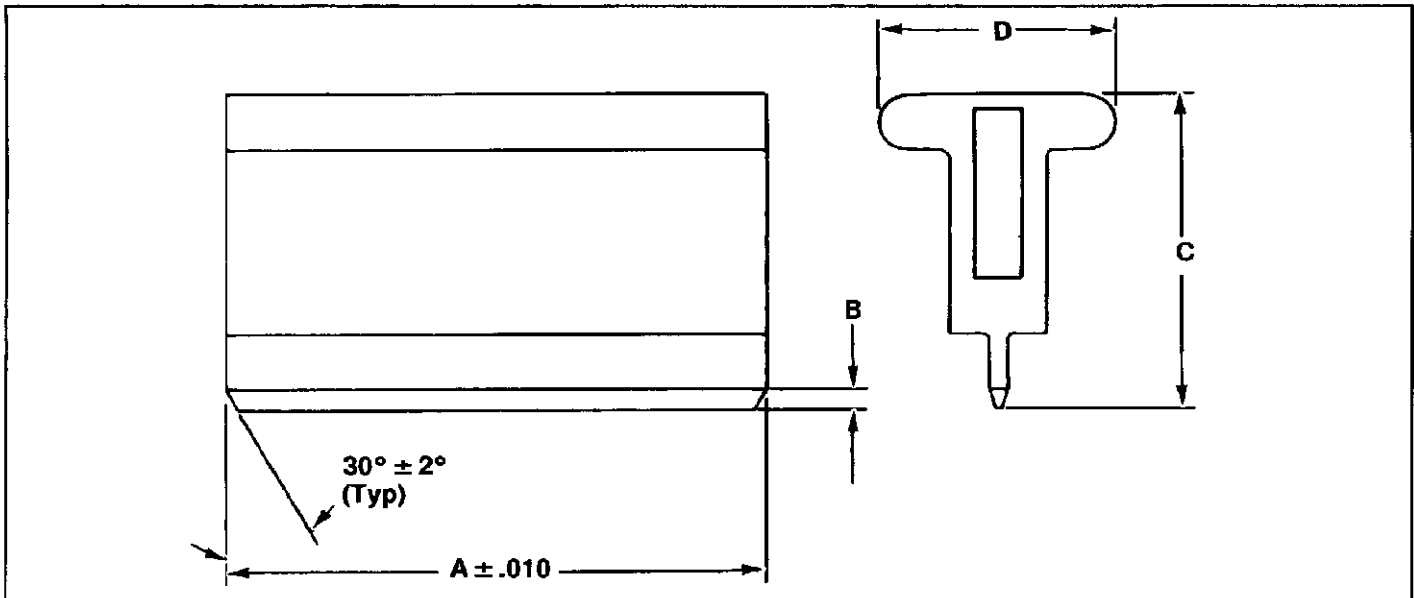

ENGINEERING APPROVAL		DATE		TOOL SPECIFICATIONS					
George Hoover		4-30-87		PART NO.	WEIGHT (Approx)	DIMENSIONS			
				58292	1 oz/in.	A	B	C	D
				Chart	.062	1.38	1.00		
TOOL PART NO.	DUAL POSITIONS			A (Length)	TOOL PART NO.	DUAL POSITIONS			A (Length)
	.100	.125	.156			.100	.125	.156	
58292-1	15			1.589	3-58292-0	44	35	28	4.485
58292-2	16			1.689	3-58292-1	45	36		4.589
58292-3	17			1.789	3-58292-2	46		29	4.665
58292-4	18			1.889	3-58292-3		37		4.735
58292-5	19	15		1.985	3-58292-4	47		30	4.789
58292-6	20	16		2.089	3-58292-5	48	38		4.860
58292-7	21			2.189	3-58292-6	49	39	31	4.985
58292-8	22	17		2.235	3-58292-7	50	40	32	5.089
58292-9	23	18		2.360	3-58292-8	51	41		5.189
1-58292-0	24	19	15	2.481	3-58292-9	52		33	5.289
1-58292-1	25	20	16	2.589	4-58292-0	53	42		5.360
1-58292-2	26	21		2.689	4-58292-1	54	43	34	5.445
1-58292-3	27		17	2.789	4-58292-2	55	44	35	5.589
1-58292-4	28	22		2.860	4-58292-3	56	45		5.689
1-58292-5	29	23	18	2.949	4-58292-4	57		36	5.757
1-58292-6	30	24	19	3.089	4-58292-5	58	46	37	5.860
1-58292-7	31	25		3.189	4-58292-6	59	47		5.985
1-58292-8	32		20	3.261	4-58292-7	60	48	38	6.069
1-58292-9	33	26	21	3.360	4-58292-8	61	49	39	6.189
2-58292-0	34	27		3.485	4-58292-9		50	40	6.360
2-58292-1	35	28	22	3.573	5-58292-0		51	41	6.485
2-58292-2	36	29	23	3.689	5-58292-1		52		6.610
2-58292-3	37			3.789	5-58292-2		53	42	6.693
2-58292-4	38	30	24	3.860	5-58292-3		54	43	6.849
2-58292-5	39	31	25	3.985	5-58292-4		55		6.985
2-58292-6	40	32		4.089	5-58292-5		56		7.110
2-58292-7	41	33	26	4.189	5-58292-6		57		7.235
2-58292-8	42			4.289	5-58292-7		58		7.360
2-58292-9	43	34	27	4.353	5-58292-8		59		7.485
					5-58292-9		60		7.610

Fig. 5