

LEGEND  = KEY PRODUCT CHARACTERISTICS

REVISION HISTORY

REV	DESCRIPTION	DATE	BY	ECN
0	FIRST ISSUE	10/12/2010	M.H	8984
1	ADD NEW P/Ns	12/06/2012	M.H	9132

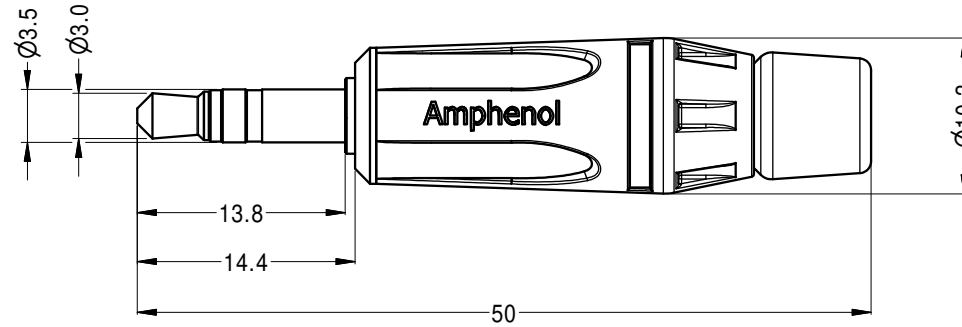
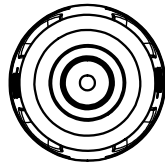

PART NUMBER		
CAT NUMBER	SHELL FINISH	CONTACT FINISH
KS3P	NICKEL COATING	NICKEL PLATING
KS3P-AU	NICKEL COATING	GOLD PLATING
KS3PB	BLACK COATING	NICKEL PLATING
KS3PB-AU	BLACK COATING	GOLD PLATING

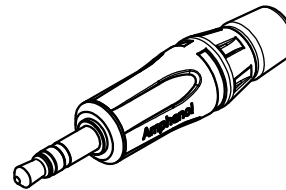

ISO VIEW ( 1 : 1 )

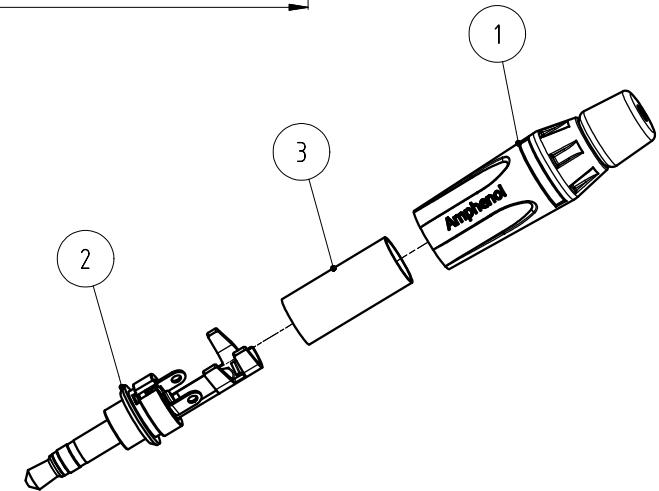

EXPLORED VIEW ( 1 : 1 )

ITEM	PART NUMBER	DESCRIPTION	QTY
3	51270077-521	INSULATE PVC TUBE CLEAR	1
2	51560089-121/321	STEREO INSERT ASSY GOLD/NICKEL PLATING	1
1	50440041-300/400	DIECAST SHELL NICKEL/BLACK FINISH	1

UNLESS OTHERWISE SPECIFIED TOLERANCE TO BE		THIS DOCUMENT IS THE PROPERTY OF AMPHENOL AUSTRALIA PTY. LTD. NO PART THEREOF MAY BE REPRODUCED AND USED WITHOUT THE PRIOR WRITTEN CONSENT OF THE OWNER	
LINEAR	ANGULAR	MATERIAL:	DRN: T.Z DATE: 10-12-10
X ± 0.5 X.X ± 0.25 X.XX ± 0.1	X' ± 1 X.X' ± 30' X.XX' ± 15'	SEE PARTS LIST & TABLE	CKD: M.H DATE: 12-06-12
BREAK ALL SHARP EDGES AND REMOVE ALL BURRS		FINISH: SEE TABLE	APP'D: P.M DATE: 12-06-12
DO NOT SCALE		DIMENSIONS IN MILLIMETRES	SCALE: 2:1 SIZE: A4

<b>Amphenol</b> Amphenol Australia Pty.Ltd, 2 Fiveways Blvd, Keysborough, VIC 3173	
TITLE: <b>3.5mm STEREO PHONE PLUG CUSTOMER DRAWING</b>	PART No: <b>SEE TABLE</b>
CAD FILE: 55010722000121	DRAWING NO. 55010722-000-1 SHEET 1/2