

THIS DRAWING IS UNPUBLISHED. RELEASED FOR PUBLICATION 20  
 © COPYRIGHT 20 BY - ALL RIGHTS RESERVED.

REVISIONS					
P	LTR	DESCRIPTION	DATE	DWN	APVD
N		REVISED DESIGN ECO-11-004745	31MAR2011	NCL	MG
NI		REVISED PER ECO-20-012432	16SEP2020	AP	DO

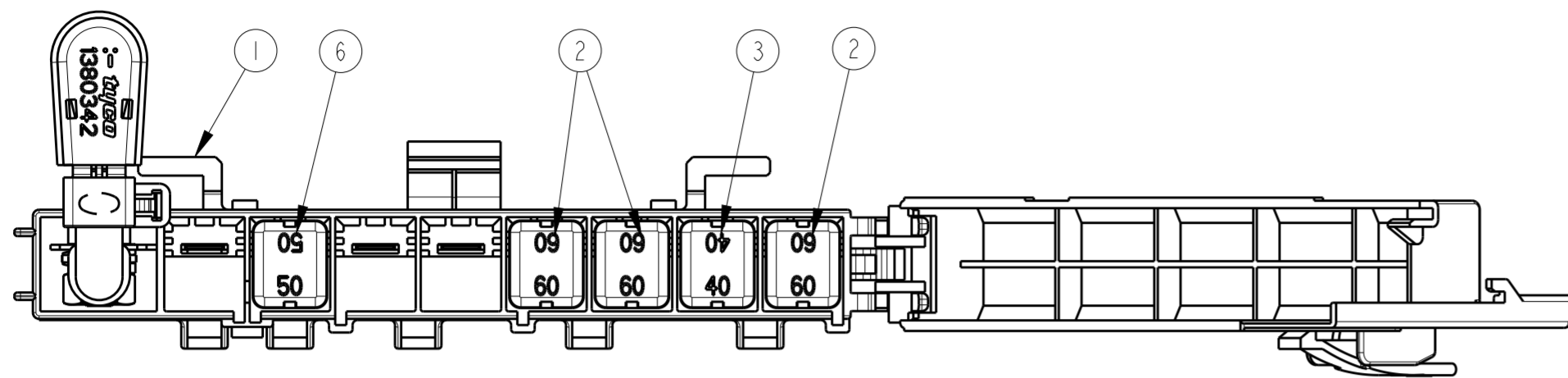

CONFIGURAÇÕES - CONFIGURATION



TE PN 1380296-1 FORD PN 2S65-14517-BD  
 SCALE 1:1

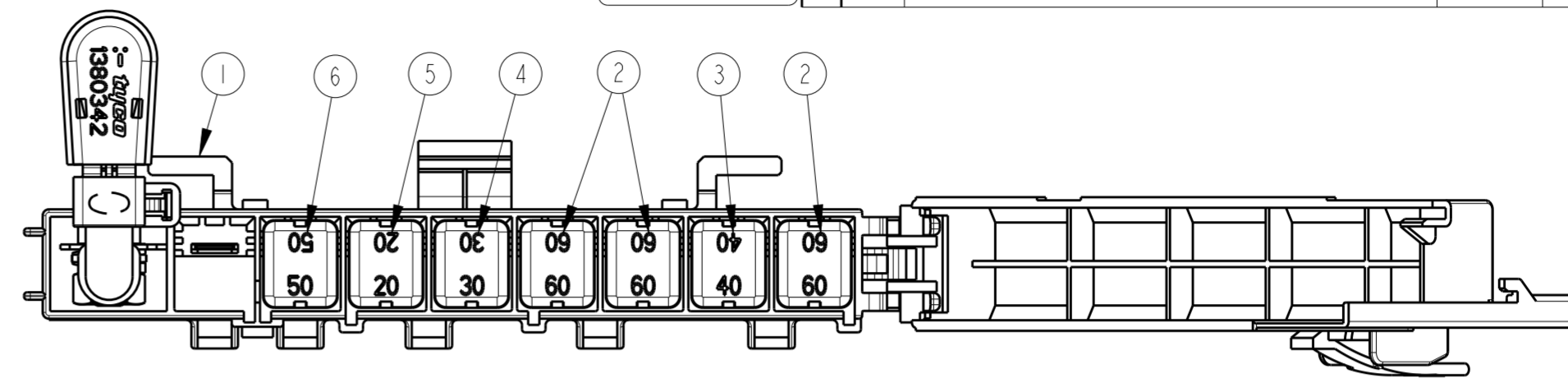

TE PN 1380296-2 FORD PN 2S65-14517-CD  
 SCALE 1:1

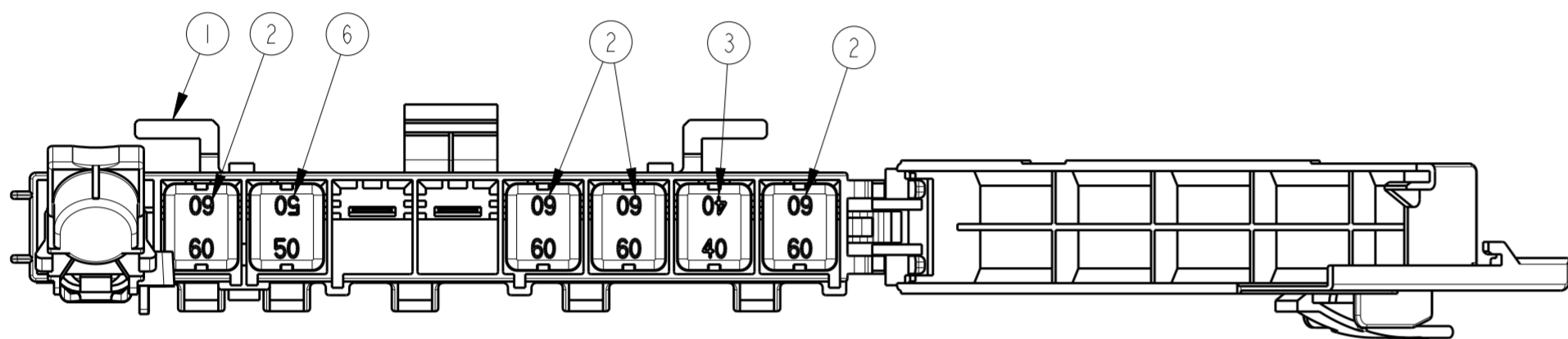

TE PN 1380296-3 FORD PN 2S65-14517-DF  
 SCALE 1:1

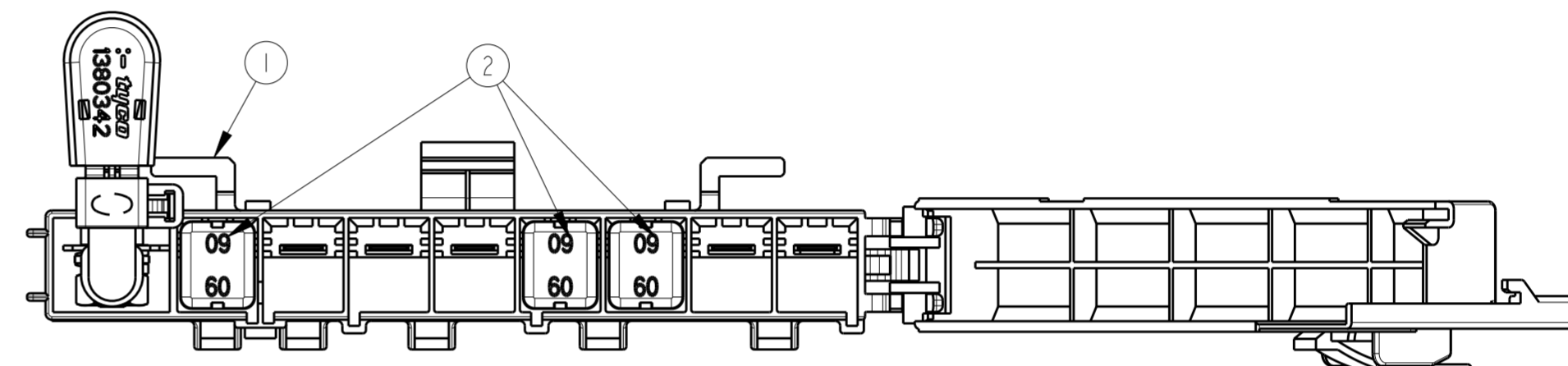

TE PN 1380296-4 FORD PN 2S65-14517-AD  
 SCALE 1:1

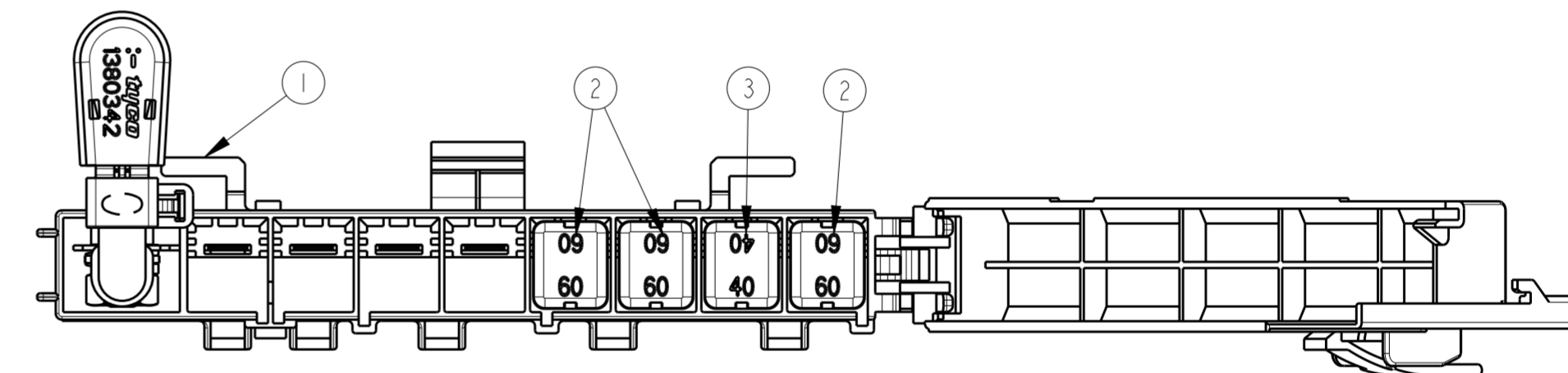

TE PN 1380296-5 FORD PN 2S65-14517-EA  
 SCALE 1:1

P/N Assy	P/N Label	Color of Label
1380296-1	0-1480657-3	AZUL / BLUE
1380296-2	0-1480657-2	BRANCO / WHITE
1380296-3	0-1480657-4	VERDE / GREEN
1380296-4	0-1480657-2	BRANCO / WHITE
1380296-5	0-1480657-5	ROSA / ROSE
1380296-6	0-1480657-2	BRANCO / WHITE
1380296-7	0-1480657-6	LILAC / LILÁS
1380296-8	0-1480657-7	LARANJA / ORANGE
1380296-9	0-1480657-8	VERMELHO / RED

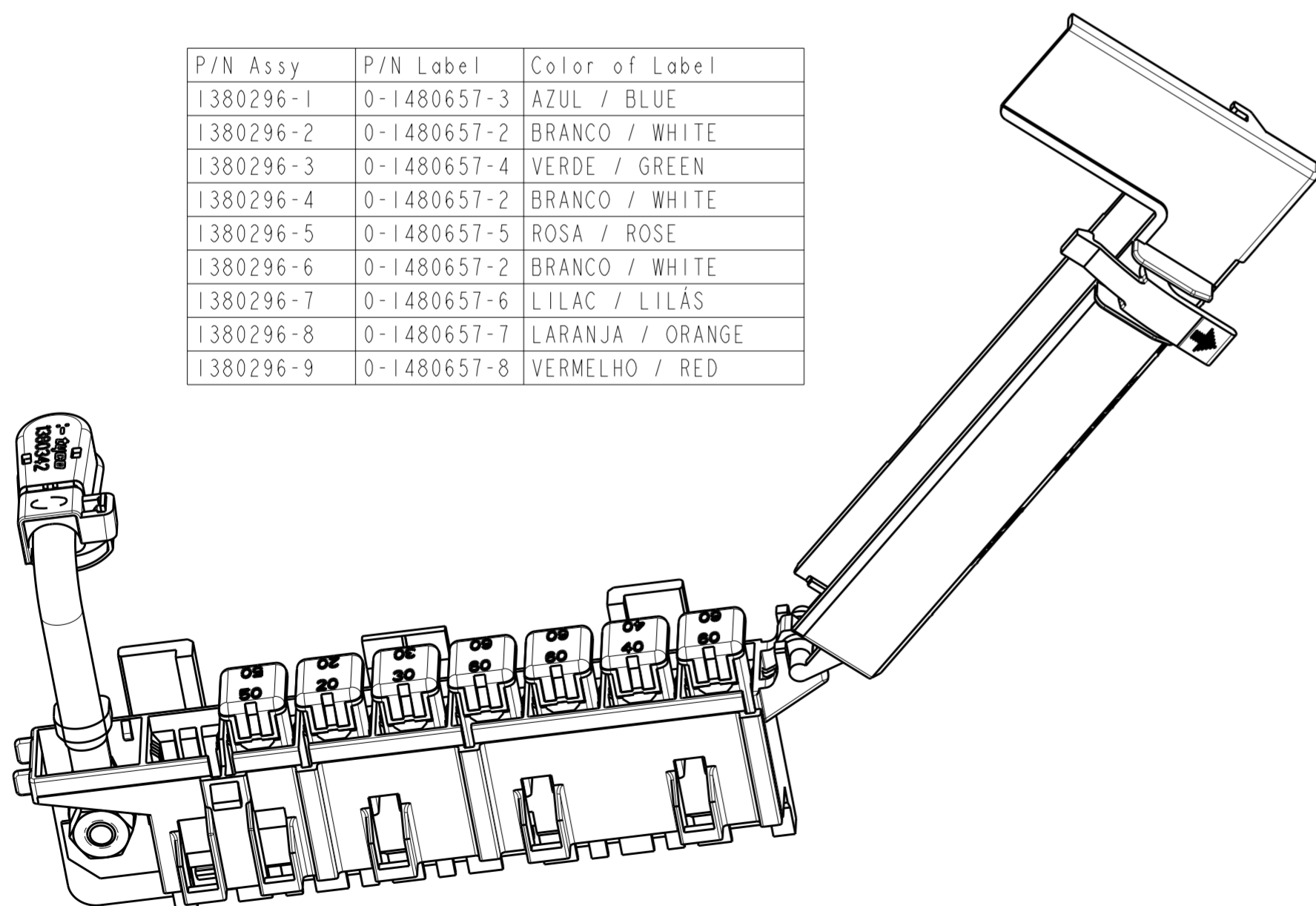

1380296-2  
 PERSPECTIVE VIEW  
 SCALE 1:1

REQ. PER ASSY	ITEM	DESCRIPTION	MATERIAL	FINISH
-	1	JCASE FUSE 50 A		
-	5	JCASE FUSE 20 A		
-	4	JCASE FUSE 30 A		
-	3	JCASE FUSE 40 A		
4	2	JCASE FUSE 60 A		
-	1	MAXI FUSE BOX ASSY 80 mm		
-	1	MAXI FUSE BOX ASSY 65 mm		
-9	1	1380296		

THIS DRAWING IS A CONTROLLED DOCUMENT.

DIMENSIONS: mm	TOLERANCES UNLESS OTHERWISE SPECIFIED: 0 PLC ± 1 PLC ± 2 PLC ± 3 PLC ± 4 PLC ± ANGLES ± FINISH	DWN M.L. OGAWA 15AUG2001 CHK P.L. FARIA 15AUG2001 APVD J.A. MARSON 22AUG2001	NAME JCASE ASSEMBLY MAXI FUSE BOX
MATERIAL		SIZE A2	CAGE CODE -
		DRAWING NO. C-1380296	RESTRICTED TO
		Customer Drawing	SCALE 1:2 SHEET 1 OF 2 REV NI

STE TE Connectivity

THIS DRAWING IS UNPUBLISHED. RELEASED FOR PUBLICATION 20  
 © COPYRIGHT 20 BY - ALL RIGHTS RESERVED.

REVISIONS				
P	LTR	DESCRIPTION	DATE	APVD
-		SEE SHEET 1	-	-

CONFIGURAÇÕES - CONFIGURATIONS

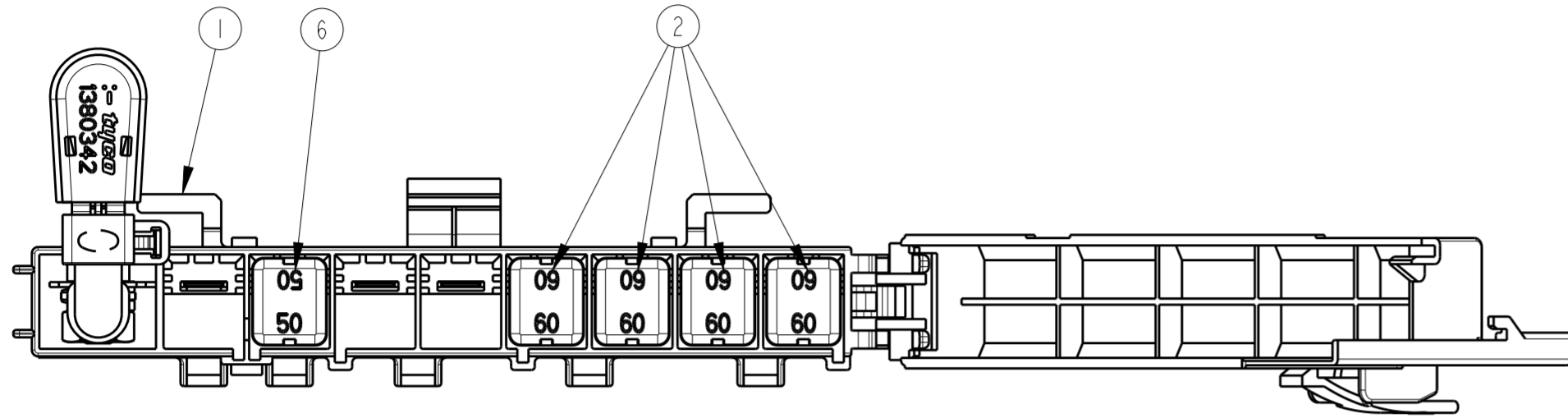

TE PN FORD PN  
 1380296-6 6S65-14517-BA  
 SCALE 1:1

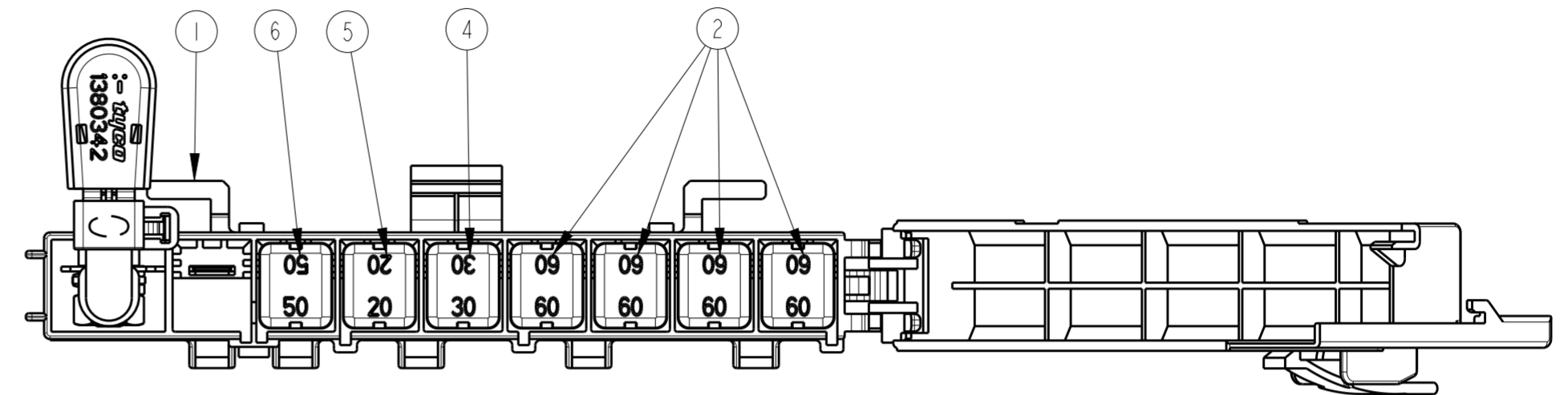

TE PN FORD PN  
 1380296-7 6S65-14517-CA  
 SCALE 1:1

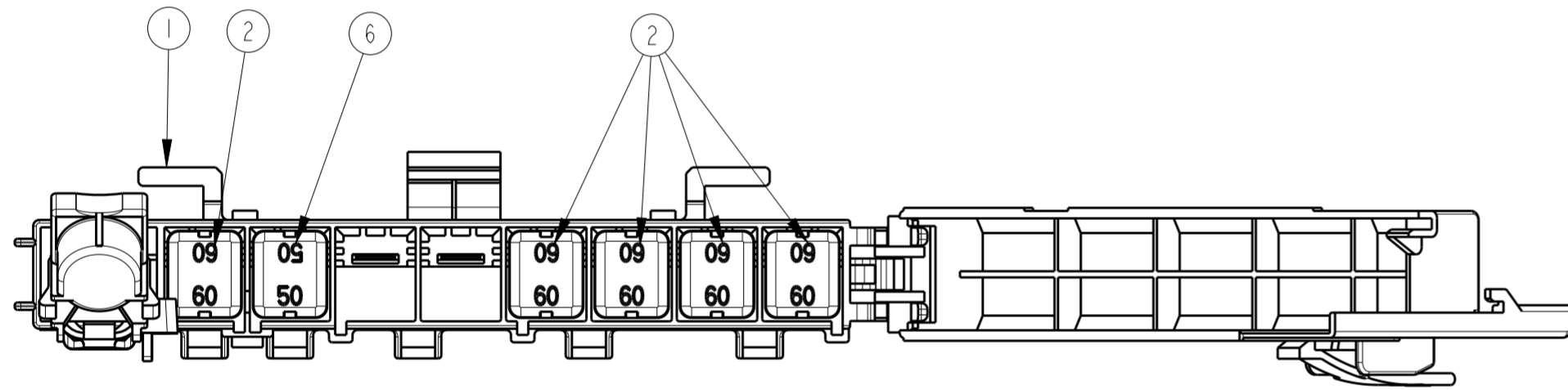

TE PN FORD PN  
~~1380296-8~~ 6S65-14517-DB  
 SCALE 1:1

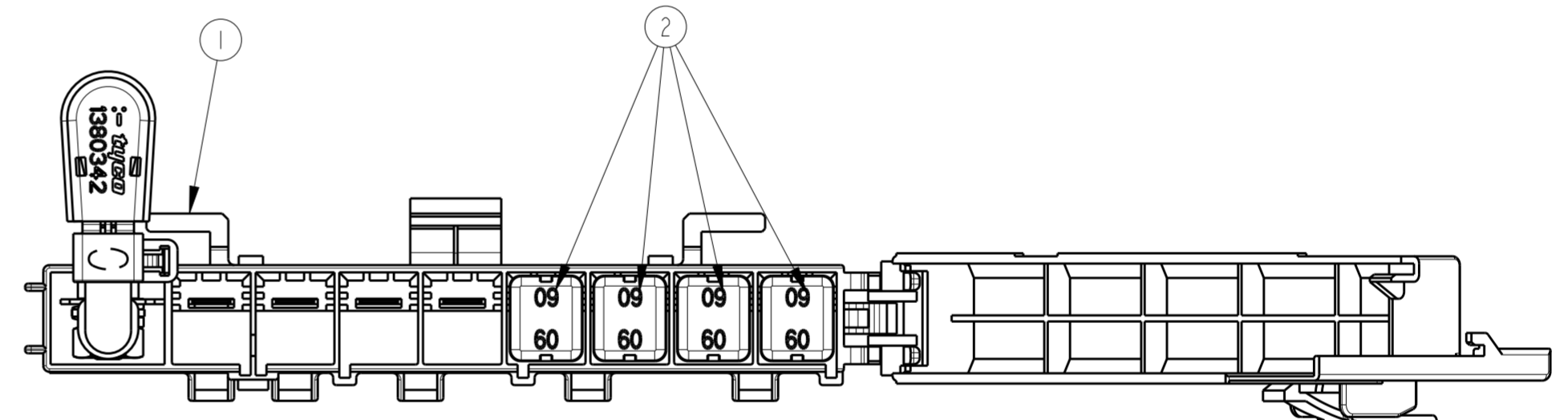

TE PN FORD PN  
 1380296-9 6S65-14517-EA  
 SCALE 1:1

THIS DRAWING IS A CONTROLLED DOCUMENT.		DWN M. L. OGAWA 15AUG2001	 TE Connectivity
DIMENSIONS: mm		CHK P. L. FARIA 15AUG2001	
TOLERANCES UNLESS OTHERWISE SPECIFIED:		APVD J. A. MARSON 22AUG2001	NAME JCASE ASSEMBLY MAXI FUSE BOX
0 PLC ± 1 PLC ± 2 PLC ± 3 PLC ± 4 PLC ± ANGLES ± FINISH -		PRODUCT SPEC -	SIZE A2
MATERIAL -		APPLICATION SPEC -	CAGE CODE -
		WEIGHT -	DRAWING NO. G-1380296
		Customer Drawing	RESTRICTED TO -
		SCALE 1:1	SHEET 2 OF 2
			REV NI