

THIS DRAWING IS UNPUBLISHED. RELEASED FOR PUBLICATION 20
 © COPYRIGHT 20 BY - ALL RIGHTS RESERVED.

REVISIONS				
P	LTR	DESCRIPTION	DATE	APVD
G		REVISED PER ECR-17-013826	20SEP2017	T.S E.T
G1		ADD P/N 6376608-4	06MAR2018	A.W R.B
G2		ADD P/N 6376608-3	18/OCT2018	A.W R.B

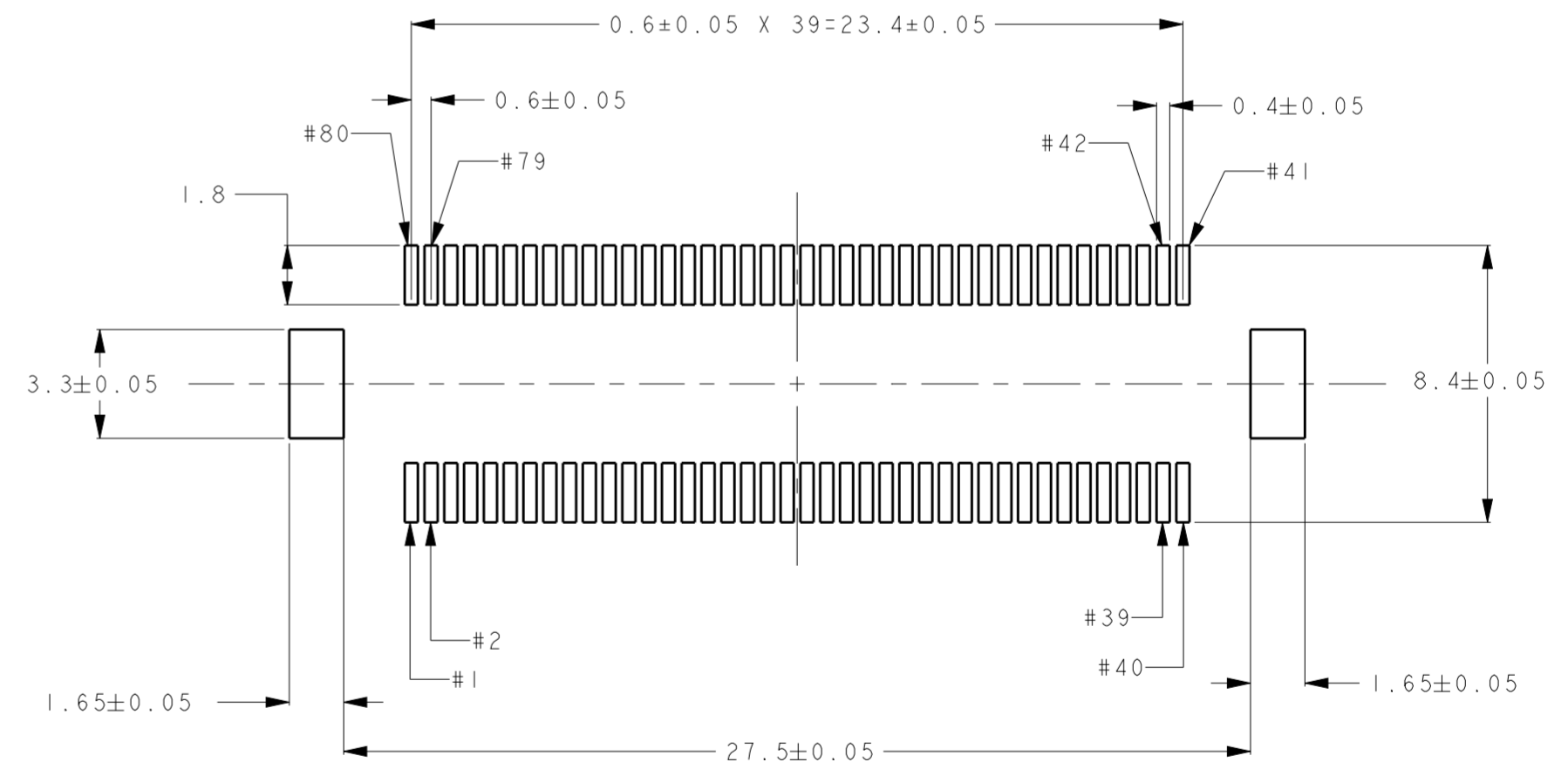
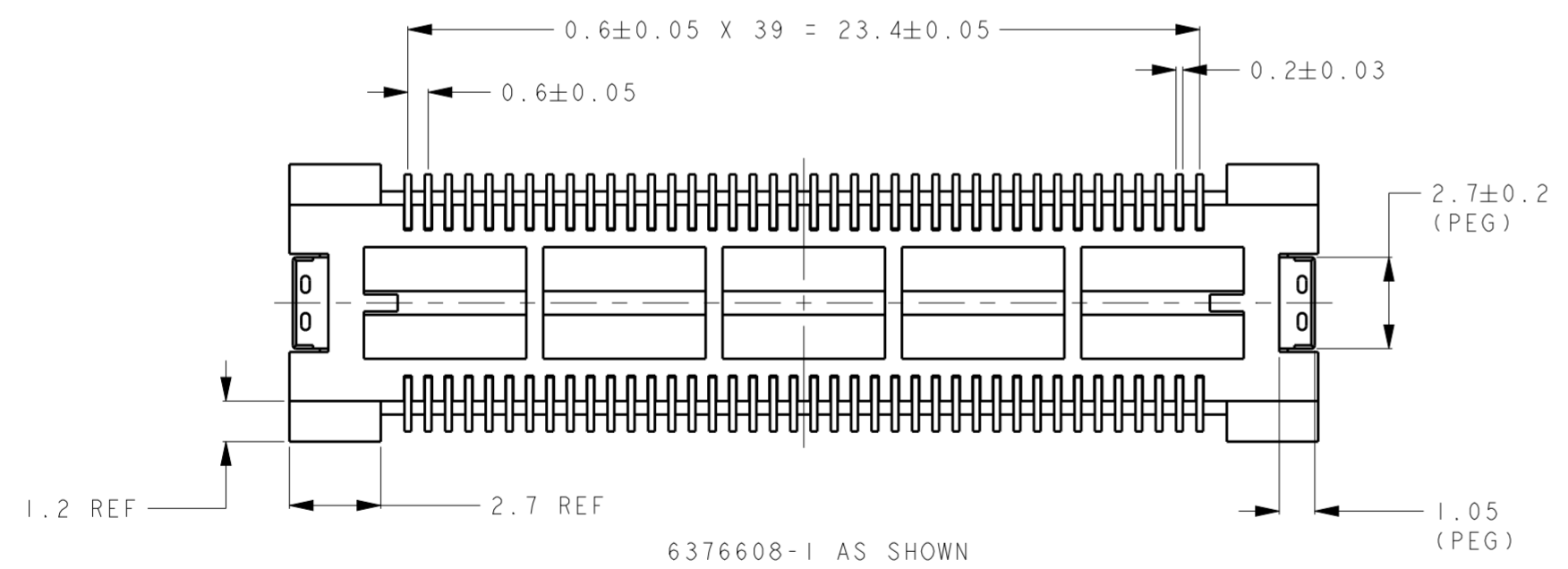
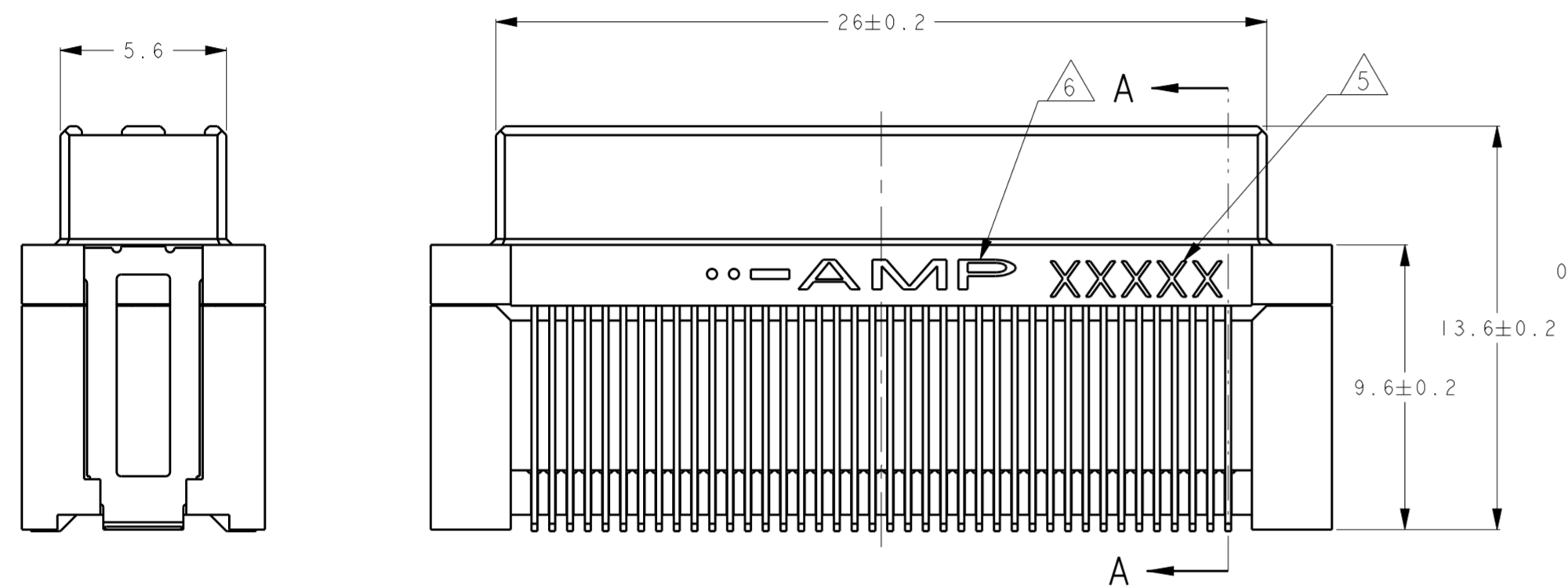
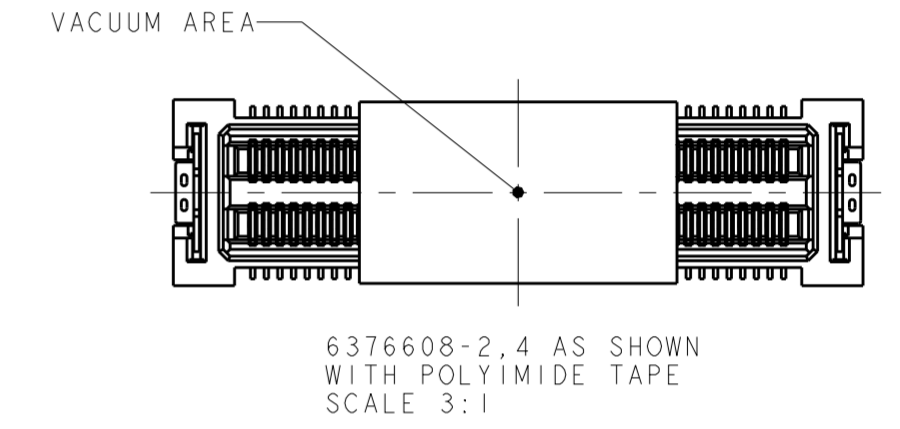
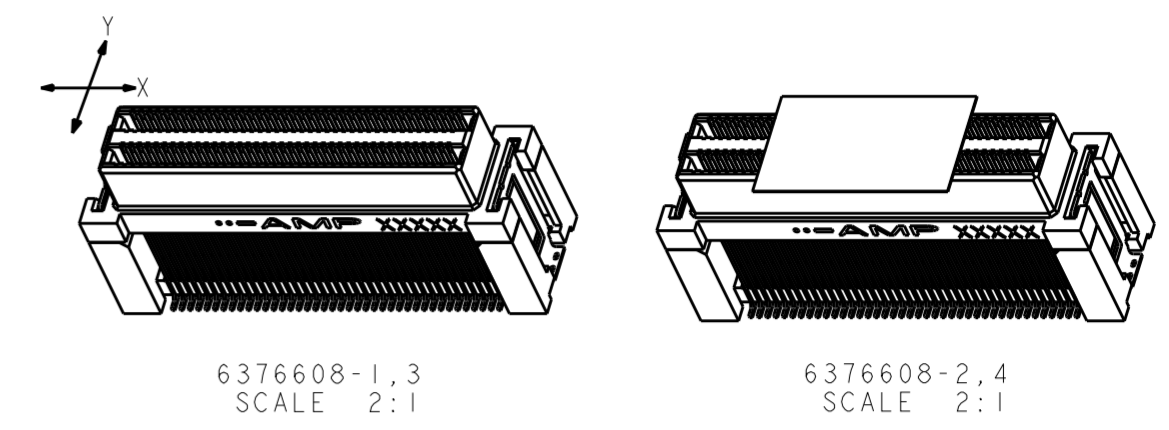
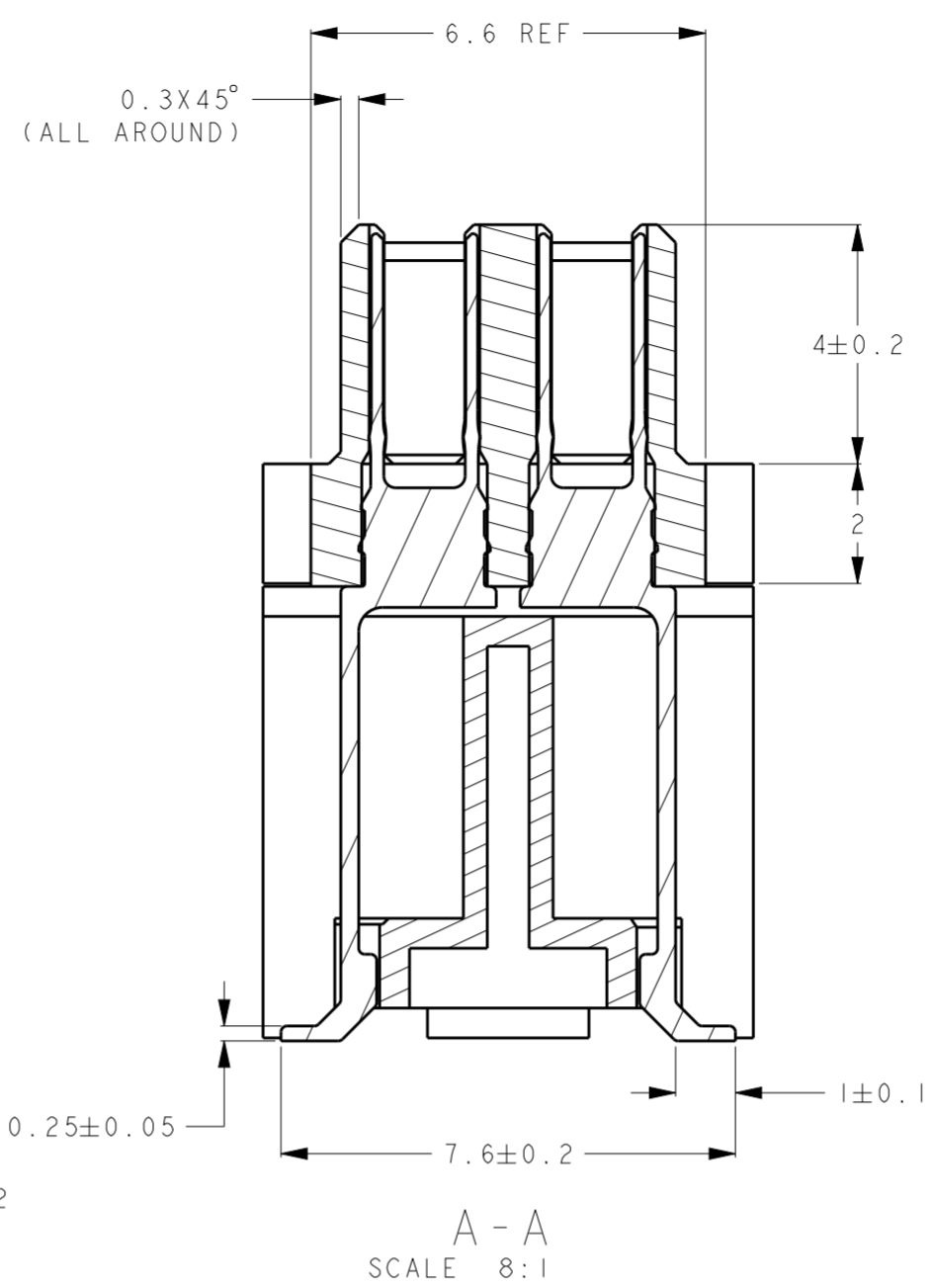
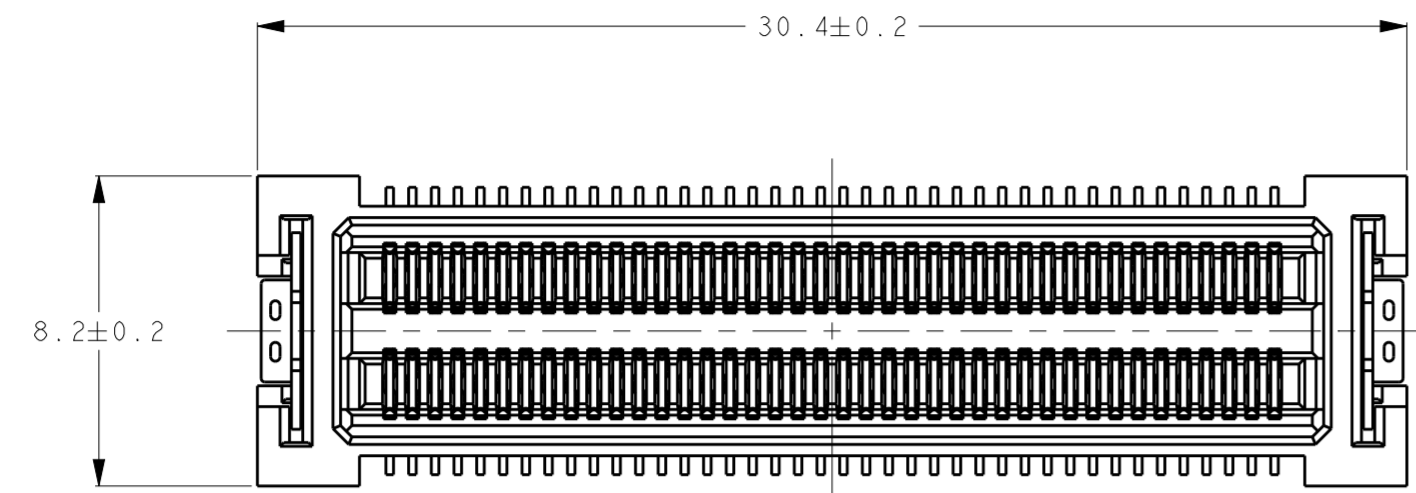

- 1 MATERIAL : HOUSING; LCP
; CONTACT; COPPER ALLOY
- 2 FINISH : UNDER Ni PL. 0.8µmMIN
CONTACT AREA: Au PL. 0.3µmMIN
SOLDERING AREA: Au FLASH
- 3. COPLANARITY 0.1MAX.
- 4. SHOULD BE PUT 45 CONNECTORS IN HARD TRAY. (SEE SHEET 2)
- 5 DATE CODE IS MARKED TO CHINA PRODUCTION PRODUCT.
THE FACE SIDE AND BACK SIDE IS NOT ASKED.
- 6 **-AMP** : MADE IN JAPAN
--AMP : MADE IN CHINA
- 7 FLOATING AMOUNT X, Y DIRECTION ±0.3mm MAX.
- 8 CONNECTORS AND TRAY SHALL BE COVERED BY PLASTIC BAG
WITH ENCLOSED DESICCANT

6376608-1 AS SHOWN

RECOMMENDED PCB LAYOUT

DESCRIPTION	PACKAGE	PART NO
WITH POLYIMIDE TAPE	TAPE REEL	-- 6376608-4
	HARD TRY	-- 6376608-2
W/O POLYIMIDE TAPE	HARD TRAY	8 6376608-3
	HARD TRAY	-- 6376608-1

THIS DRAWING IS A CONTROLLED DOCUMENT.

DIMENSIONS: mm	TOLERANCES UNLESS OTHERWISE SPECIFIED: 0 PLC ±0.3 1 PLC ±0.25 2 PLC ±0.2 3 PLC ± 4 PLC ± ANGLES ±3° FINISH	DWN K.Sakai 23JAN2006 CHK E.Takemasa 23JAN2006 APVD M.Kimura 23JAN2006	TE Connectivity NAME REC ASSEMBLY MICRO-STACK CONNECTOR 0.6mm PITCH 80P
MATERIAL SEE NOTE 1	SEE NOTE 2	PRODUCT SPEC 108-5724 APPLICATION SPEC	
CUSTOMER DRAWING		WEIGHT 3.0g	SIZE A2 CAGE CODE 0779 DRAWING NO G-6376608 RESTRICTED TO
		SCALE 5:1	SHEET 1 OF 3 REV G2

THIS DRAWING IS UNPUBLISHED. RELEASED FOR PUBLICATION 20
 © COPYRIGHT 20 BY - ALL RIGHTS RESERVED.

REVISIONS				
P	LTR	DESCRIPTION	DATE	APVD
-		SEE SHEET 1	-	-

- 1: AS SHOWN

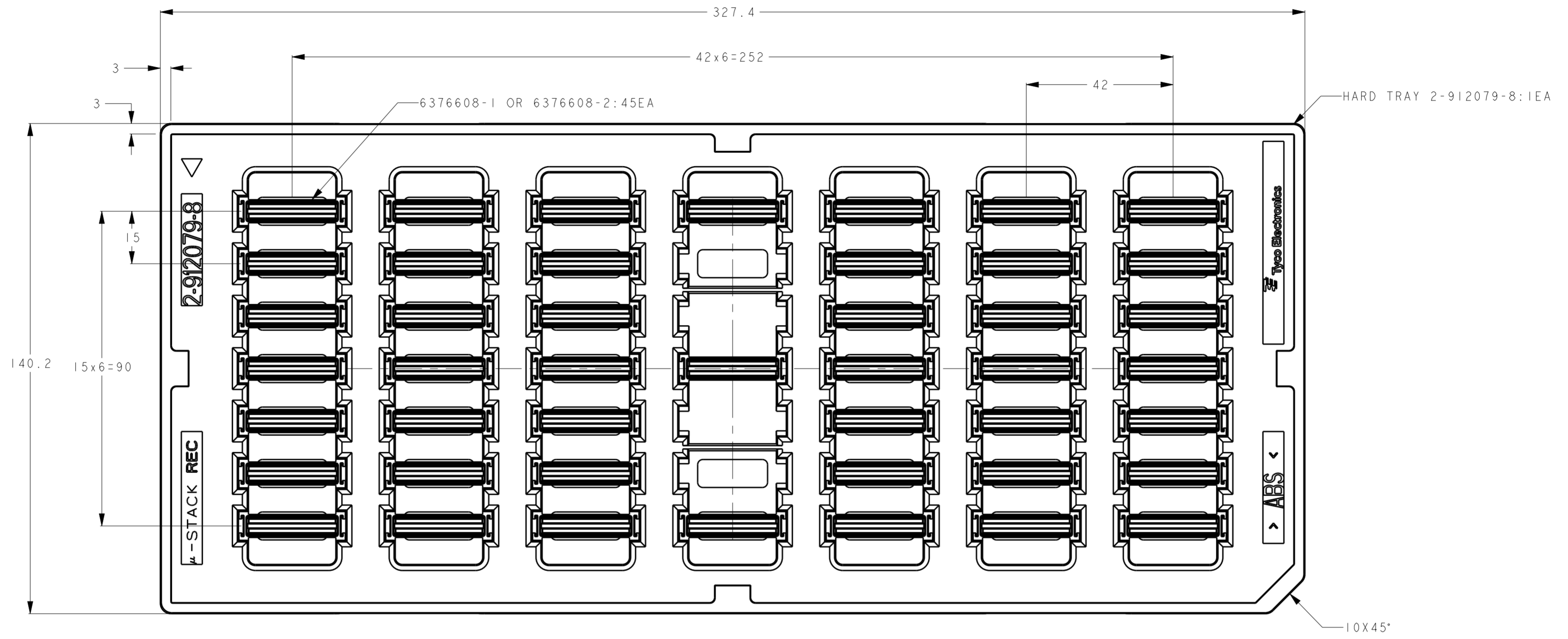

HARD TRAY PACKING SPEC

45	BLACK
CONN QTY	HARD TRAY COLOR

THIS DRAWING IS A CONTROLLED DOCUMENT.		DWN K. Sakai 23JAN2006	TE Connectivity
DIMENSIONS: mm		CHK E. Takemasa 23JAN2006	
		APVD M. Kimura 23JAN2006	
TOLERANCES UNLESS OTHERWISE SPECIFIED: 0-PLC ± 1 1-PLC ± 0.3 2-PLC ± 0.25 3-PLC ± 0.2 4-PLC ± 0.1 ANGLES ± 3° FINISH -		PRODUCT SPEC 108-5724 APPLICATION SPEC - WEIGHT 3.0g CUSTOMER DRAWING	
NAME		REC ASSEMBLY MICRO-STACK CONNECTOR 0.6mm PITCH 80P	
SIZE	CAGE CODE	DRAWING NO	RESTRICTED TO
A2	0779	C-6376608	
SCALE 1:1		SHEET 2 OF 3	REV G2

THIS DRAWING IS UNPUBLISHED. RELEASED FOR PUBLICATION 20
 © COPYRIGHT 20 BY - ALL RIGHTS RESERVED.

REVISIONS				
P	LTR	DESCRIPTION	DATE	APVD
-		SEE SHEET 1	-	-

- 4: AS SHOWN

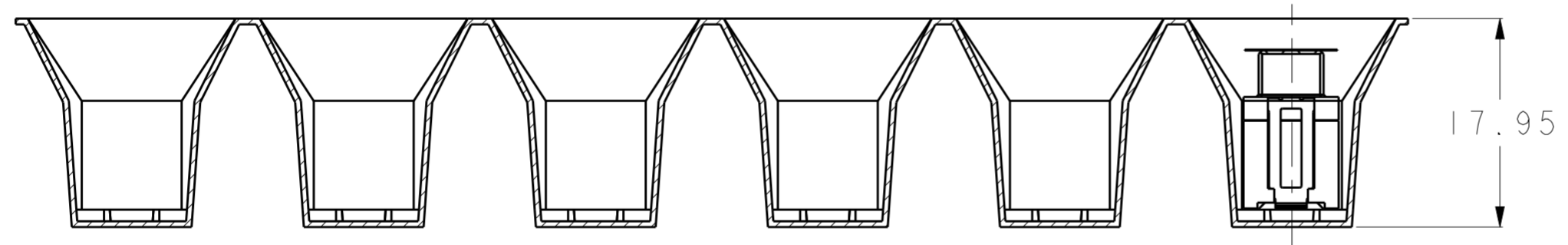
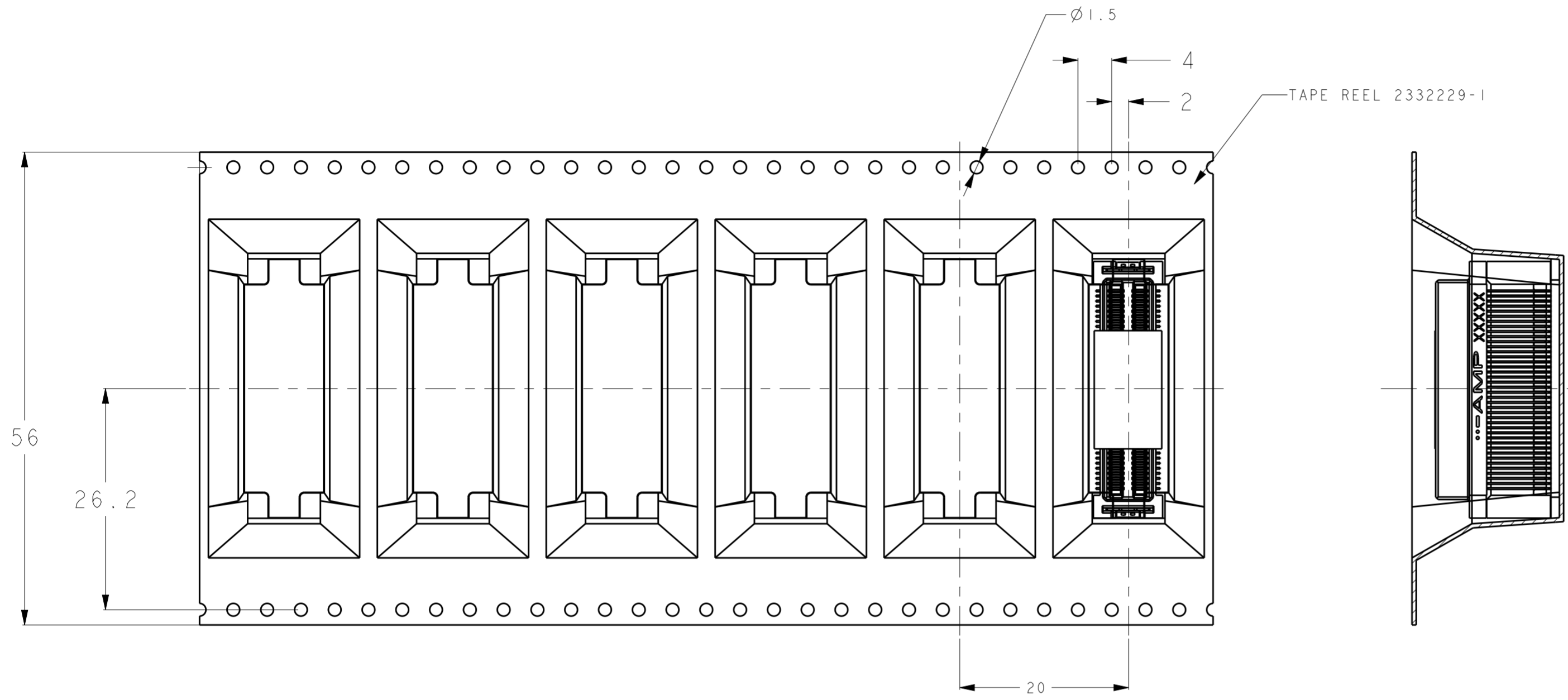

TAPE REEL PACKING SPEC.

160/R	WHITE
CONN QTY	TAPE REEL COLOR

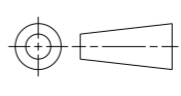
THIS DRAWING IS A CONTROLLED DOCUMENT.		DWN K. Sakai 23JAN2006	 TE Connectivity
DIMENSIONS: mm		CHK E. Takemasa 23JAN2006	
		APVD M. Kimura 23JAN2006	
TOLERANCES UNLESS OTHERWISE SPECIFIED: 0-PLC ± 1 1-PLC ± 0.3 2-PLC ± 0.25 3-PLC ± 0.2 4-PLC \pm ANGLES $\pm 3^\circ$ FINISH -		PRODUCT SPEC 108-5724 APPLICATION SPEC - WEIGHT 3.0g CUSTOMER DRAWING	
NAME REC ASSEMBLY MICRO-STACK CONNECTOR 0.6mm PITCH 80P		SIZE A2	CAGE CODE 0779
DRAWING NO C-6376608		RESTRICTED TO	
SCALE 1:1		SHEET 3 OF 3	REV G2