

PART NUMBER	REV	TERMINATOR	FEED TYPE	DESCRIPTION
1529212-1	A	BENCH & LEADMAKER	MECH POST FEED	HDI APPLICATOR
7-1529212-1	A	BENCH & LEADMAKER	MECH POST FEED	-1 AND SPARE PARTS
7-1529212-7	A	-	-	SPARE PARTS KIT

LOC	DIST	REV	DATE	BY	APPD
A	66	A	25JAN2007	LJL	MC

CRIMP DATA FCI / BERG TERMINAL TYCO CRIMP SPECS

TERMINAL NAME: MINI PV RECEPTACLE, CRIMP TO WIRE

CRIMP	SIZE	TYPE	RANGE
WIRE	1.07 [.042 IN]	F	32-28 AWG
INSUL	1.57 [.062 IN]	O	0.71-1.37 [.028-.054 IN]

WIRE STRIP LENGTH 4.06 [.160 IN] APPL INSTRUCTIONS 408-8323 & 408-8490

TERMINAL FCI DRG 47212 FEED 15.25 [.600 IN]
 APPL SPEC DUPONT DRG. TA-146

TERMINALS APPLIED

TYCO TERM PN	MANUF TERM PN		
1949232-1	47564-000	-	-
1949232-2	47564-001	-	-
1949232-3	47564-002	-	-

WIRE SIZE	CRIMP HEIGHT	REF SETTING
28 AWG	0.71 ±0.05 [.028 ±.002 IN]	C 5
30 AWG	0.69 ±0.05 [.027 ±.002 IN]	C 7
32 AWG	0.66 ±0.05 [.026 ±.002 IN]	C 9

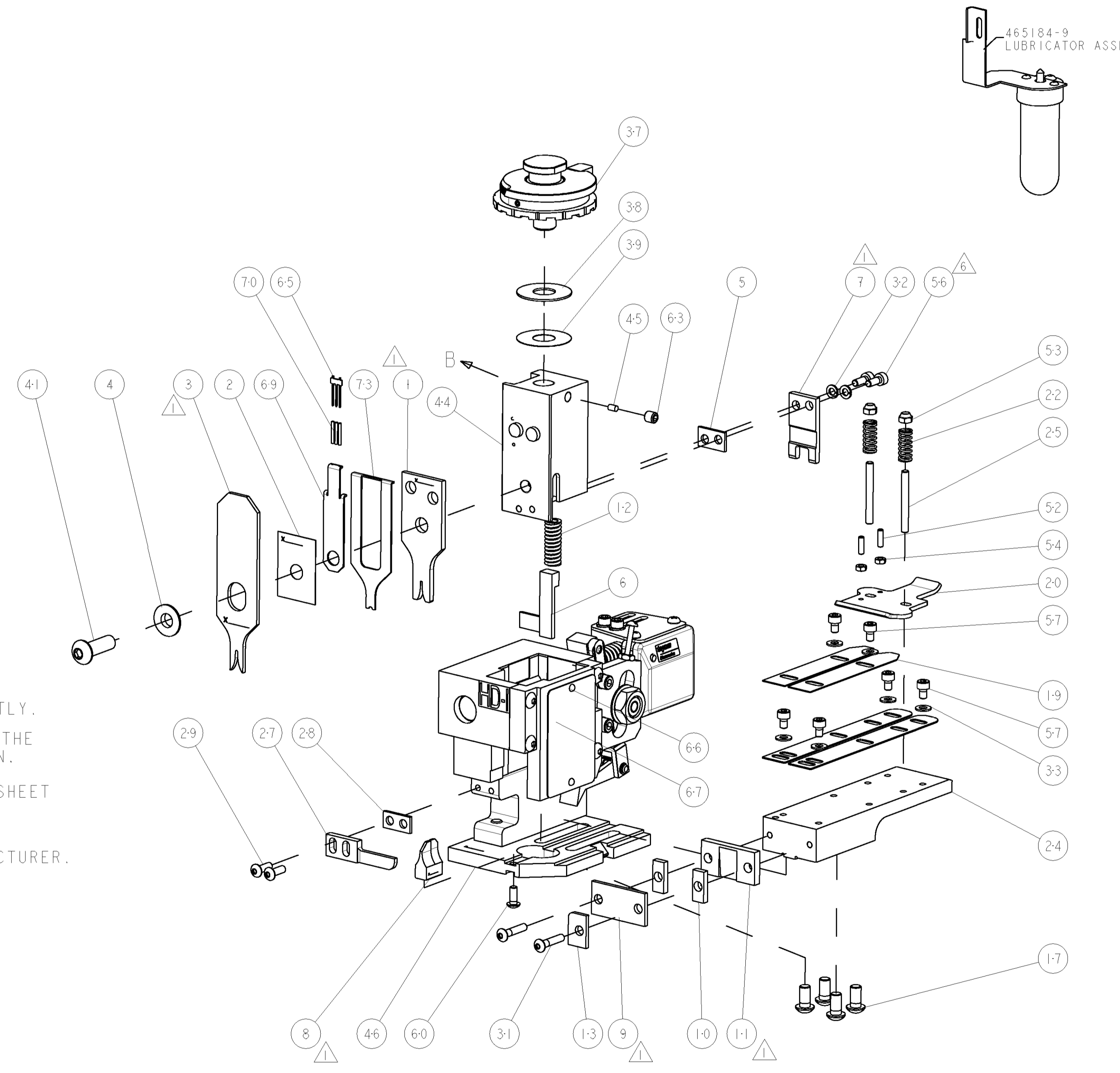

- 1 RECOMMENDED SPARE PARTS
- 2. GREASE RAM, CAM, CAM FOLLOWER AND FEED ROD LIGHTLY.
- 3 CERTAIN TERMINALS REQUIRE LUBRICATION. REFER TO THE APPLICATOR INSTRUCTION SHEET FOR MORE INFORMATION.
- 4. LUBRICATE DAILY PER THE APPLICATOR INSTRUCTION SHEET SUPPLIED WITH THE APPLICATOR.
- 5 ALL CRIMP WIDTHS CALCULATED BY TYCO ELECTRONICS, CRIMP HEIGHTS AS RECOMMENDED BY TERMINAL MANUFACTURER.
- 6 CUT TO LENGTH AT ASSEMBLY.

*** WARNING**

ON INSTALLATION, SET WIRE DISC TO LARGEST WIRE SIZE SETTING. USE OF SETTINGS BELOW MIN. REQUIRED CRIMP HEIGHT SETTING WILL CAUSE DAMAGE TO CRIMP TOOLING.

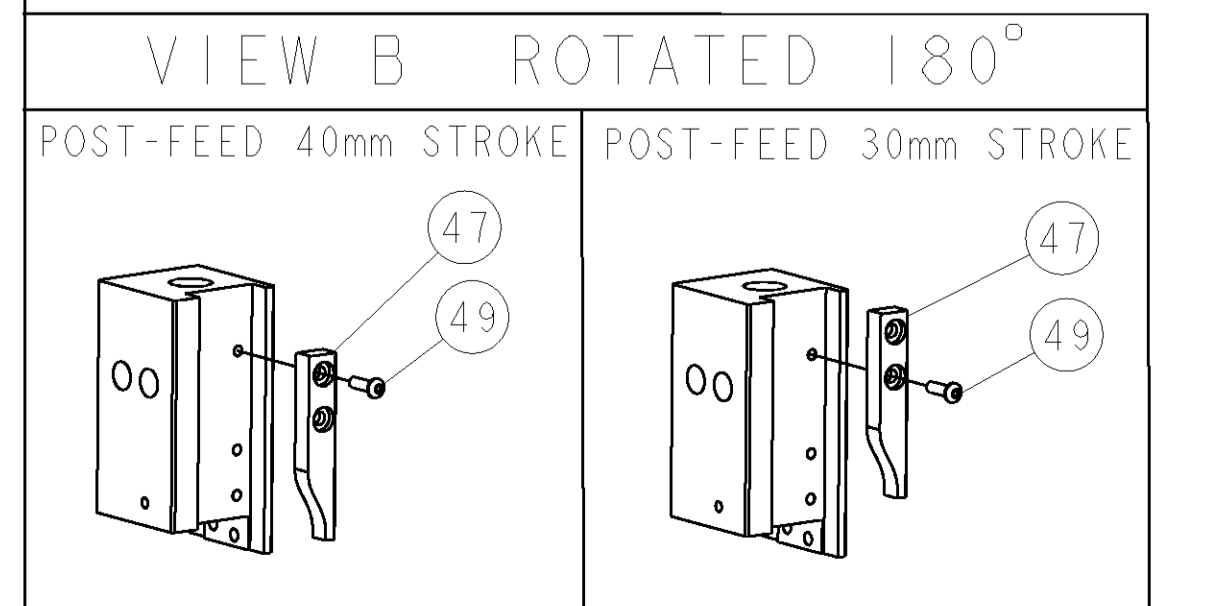

-	1	1	1490525-2	DEPRESSOR, WIRE	73
-	1	1	1338705-4	DOCUMENTATION PACKAGE	71
-	3	3	1-23147-4	SPRING, COMPRESSION	70
-	1	1	1490524-2	DEPRESSOR, SPACER	69
-	1	1	461264-5	PLATE, IDENTIFICATION	67
-	2	2	21017-2	SCREW, DRIVE	66
-	1	1	1424350-1	HOLDER, PIN, WIRED	65
-	1	1	3-18031-0	SCR, SET, CUP POINT M6 X 6.0	63
-	1	1	18024-7	SCR, BTN SKT HD CAP (M4 X 10.0)	60
-	6	6	18023-9	SCR, SKT HD CAP M4 X 6.0	57
-	2	2	1-18023-1	SCR, SKT HD CAP M4 X 10.0	56
-	2	2	18029-1	NUT, HEX, REG M3	54
-	2	2	986965-1	NUT, LOCK, HEX, TORQUE (M4)	53
-	2	2	2-18032-2	SCR, SET, FLT POINT M3 X 10.0	52
-	1	1	18024-3	SCR, BTN SKT HD CAP (M3 X 10.0)	49
-	1	1	1338676-1	CAM, UNIVERSAL POST-FEED	47
-	1	1	1338662-1	SUB ASSY, APPLICATOR FRAME	46
-	1	1	690191-1	PLUG, NYLON	45
-	1	1	1320998-1	RAM	44
-	1	1	2-18024-6	SCR, BTN SKT HD CAP (M8 X 25.0)	41
-	1	1	690125-1	SHIM SUB-ASSY	39
-	1	1	469367-7	SHIM	38
-	1	1	879103-3	FINE ADJUST HEAD ASSEMBLY	37
-	6	6	18027-2	WASHER, FLAT, REG M4	33
-	2	2	18025-2	WASHER, SPRG LOCK, REG M4	32
-	2	2	1-18024-0	SCR, BTN SKT HD CAP (M4 X 20.0)	31
-	2	2	18024-8	SCR, BTN SKT HD CAP (M4 X 12.0)	29
-	1	1	3-690451-2	SPACER, STRIPPER	28
-	1	1	240639-1	STRIPPER (MACHINING)	27
-	2	2	1320906-1	STUD, THREADED	25
-	1	1	1320995-1	PLATE, STRIP GUIDE	24
-	2	2	4-22281-1	SPRING, DRAG	22
-	1	1	1338665-1	DRAG	20
-	2	2	1338664-1	GUIDE, UPPER STRIP	19
-	2	2	1338663-9	GUIDE, LOWER STRIP	18
-	4	4	1-18024-8	SCR, BTN SKT HD CAP (M6 X 12.0)	17
-	1	1	3-690481-2	SPACER, HOLD DOWN	13
-	1	1	23846-1	SPRING, DIE	12
-	1	1	240644-1	PLATE, REAR SHEAR	11
-	2	2	2-240645-7	SPACER, SHEAR PLATE	10
-	1	1	2-240642-2	PLATE, FRONT SHEAR	9
-	1	2	1-1633383-0	ANVIL, COMBINATION	8
-	1	1	7-240651-4	BLADE, SLUG	7
-	1	1	3-455892-8	HOLD DOWN, TERMINAL	6
-	1	1	3-240641-3	SPACER	5
-	1	1	238009-8	BLOCK, FL CRIMPER SPACER	4
-	1	2	1-4904741-3	CRIMPER, INSUL O PREMIUM	3
-	1	1	455888-1	SPACER, CRIMPER	2
-	1	2	1-456401-0	CRIMPER, WIRE PREMIUM	1

ITEM NO	PART NO	DESCRIPTION			
-77	-71	-1	PART NO	DESCRIPTION	ITEM NO

DATE	21DEC2006	BY	L LOFTHOUSE
CHK		NAME	M CLIFFORD
DATE	21DEC2006	PRODUCT SPEC	
APPL		APPLICATION SPEC	
MATERIAL		WEIGHT	
FINISH		CUSTOMER DRAWING	

TYCO Electronics Tyco Electronics Harrisburg, PA 17105-3608

PRODUCT NAME: FINE ADJUST END FEED HDI APPLICATOR

SCALE: 3:5 SHEET 1 OF 1 REV A