

PART NUMBER	REV	FIRST USED
680708-1	A	122500-1
680708-2	A	565435-5
680708-3	A	354500-1

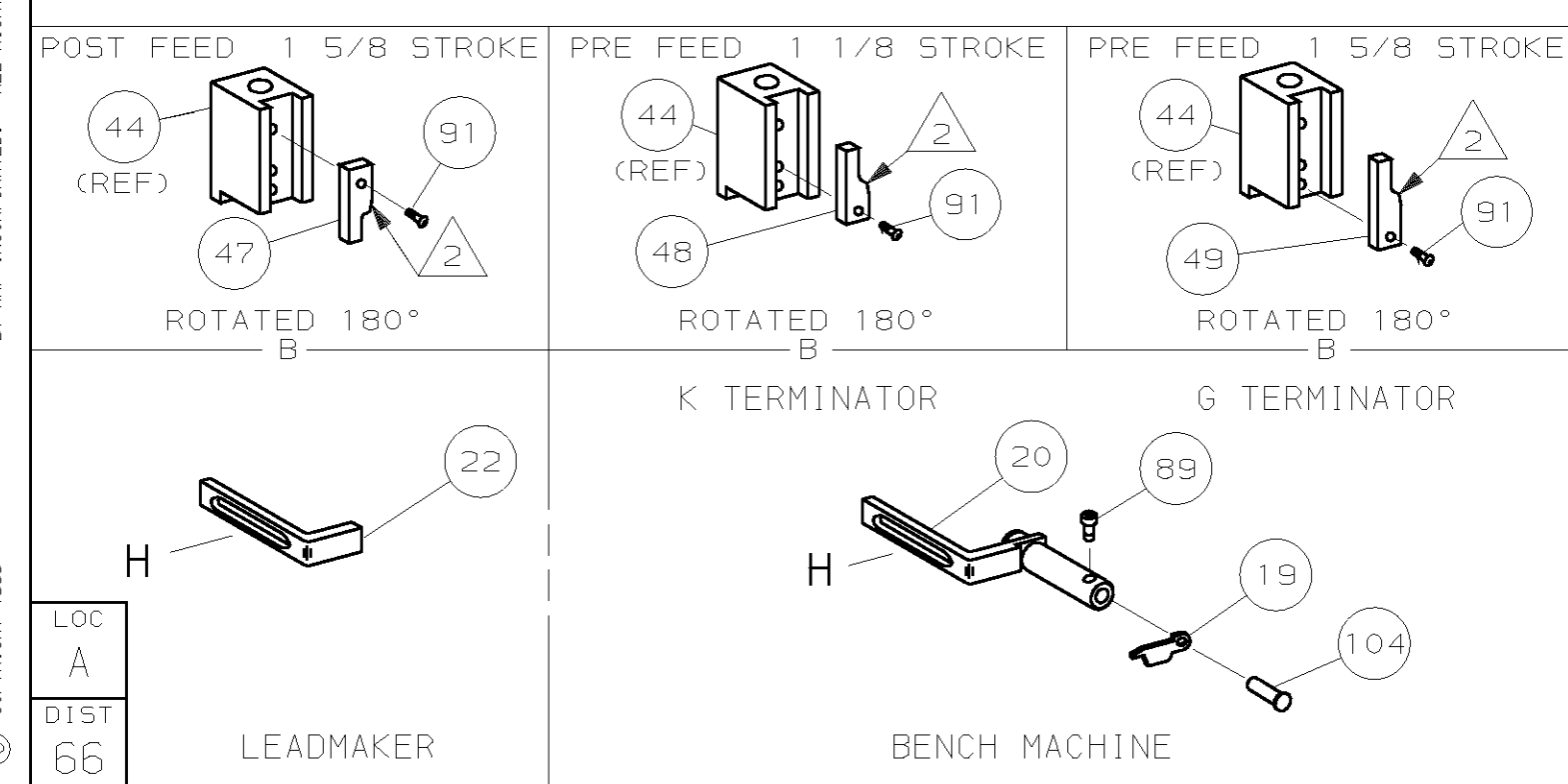
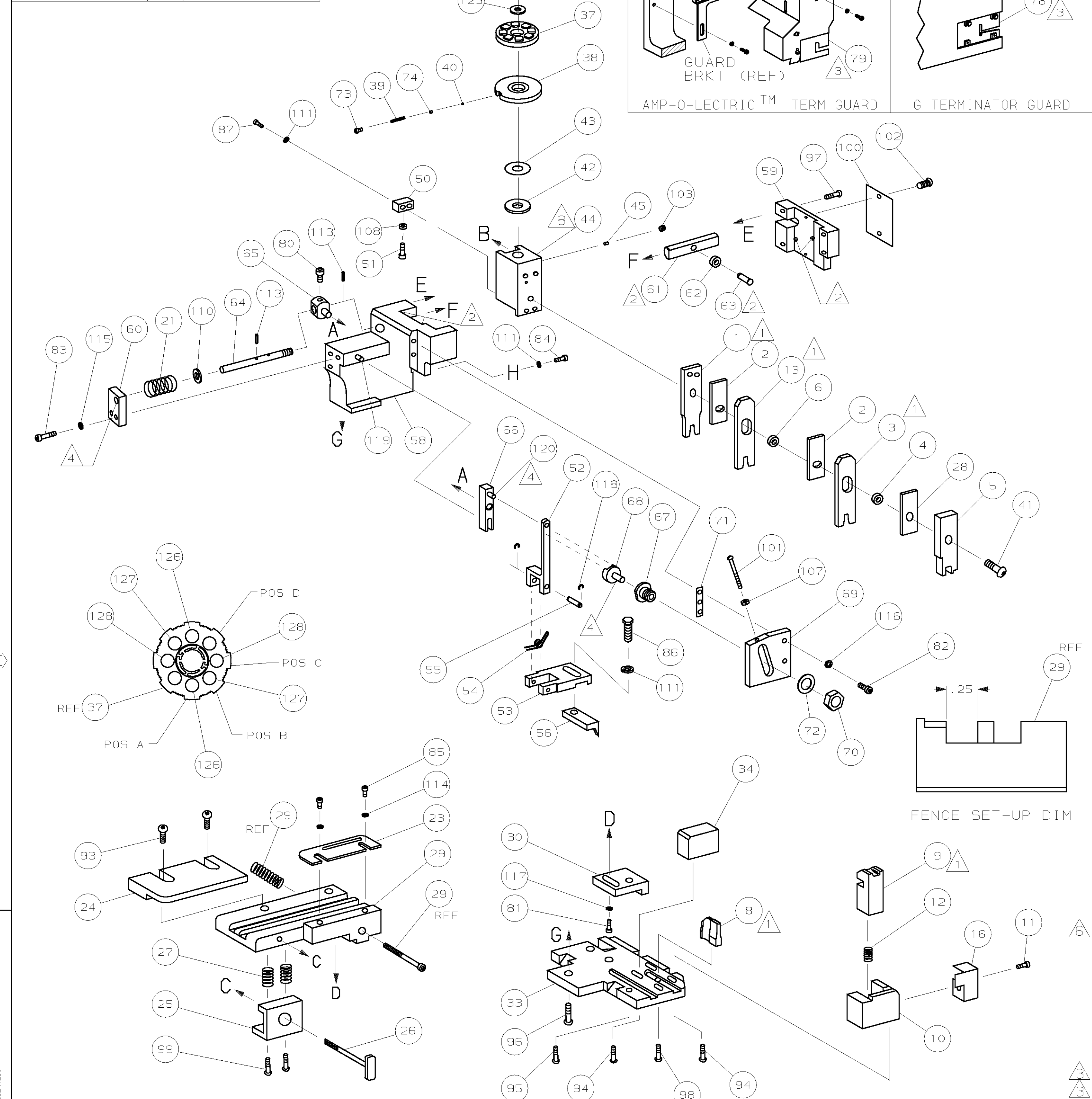

- 1 RECOMMENDED SPARE PARTS.
- 2 GREASE LIGHTLY.
- 3 GUARD MUST BE IN PLACE WHEN OPERATING APPLICATOR IN A BENCH MACHINE.
- 4 LUBRICATE DAILY USING NO. 20 MACHINE OIL.
- 5. ITEMS WITH QTY OF REF SPECIFIED (EXCEPT ITEMS 78 AND 79) ARE USED ON ITEM 46.
- 6 CUT TO LENGTH AT ASSY
- 7 GUIDE OFF STABILIZER BARREL.
- 8 PRESS SPRING PIN INTO RAM, FLUSH WITH WIRE CRIMPER, AT ASSEMBLY.

TERMINAL NAME: .140 Ø SOCKET			
927818	CRIMP DATA (AMP TERMINAL)		
PAD LTR	CRIMP HEIGHT	WIRE SIZE	
A	.056 ±.002 [1.42 ±0.05mm]	1 mm ²	
B	.052 ±.002 [1.33 ±0.05mm]	0.75 mm ²	
C	.049 ±.002 [1.24 ±0.05mm]	0.5 mm ²	
D	NOT	USED	
CRIMP	SIZE	TYPE	RANGE
WIRE	.080 [2.03mm]	F	0.5mm ² -1mm ²
INSUL	.130 [3.30mm]	F	2.0-2.7mm

QTY	REF	REF	REF	REF	REF	DESCRIPTION	ITEM NO
2	2	2	-	C	2-354779-9	PIN, WIRE DISC (.3135)C	129
2	2	2	-	C	2-354779-3	PIN, WIRE DISC (.3105)B	127
2	2	2	-	C	1-354779-4	PIN, WIRE DISC (.3060)A	126
1	1	1	-	A	986950-1	WASHER, FLAT PRECISION	125
1	1	1	-	A	217238-1	GENERAL INSTRUCTION PACKAGE	124
1	1	1	-	-	4088040	SF APPL INST 408-8040	123
REF	REF	REF	-	A	1-21030-1	PIN, DOWEL (Ø.187x.50) LEVER	120
REF	REF	REF	-	A	1-21030-6	PIN, DOWEL (Ø.187x1.25) HOUSING	119
REF	REF	REF	-	A	21045-3	RING, RET "C" (Ø.187) FD FING PIN	118
1	1	1	-	A	21024-5	WASHER, LOCK (#10) ADJ BLOCK	117
REF	REF	REF	-	A	21024-5	WASHER, LOCK (#10) ADJ PLATE	116
REF	REF	REF	-	A	21024-5	WASHER, LOCK (#10) FEED GDE ROD	115
2	2	2	-	A	21024-2	WASHER, LOCK (#4) FRONT STP GUIDE	114
REF	REF	REF	-	A	5-21028-1	PIN, 5LT 5PR (Ø.125x.50) ADJ ROD	113
4	4	4	-	A	21024-4	WASHER, LOCK (#8) STRIPPER	111
REF	REF	REF	-	A	21899-4	WASHER, FLAT (Ø5/16) SCREW ADJ	110
1	1	1	-	A	21018-5	NUT, HEX (NO. 6) HOLDDOWN	108
REF	REF	REF	-	A	21068-5	NUT, HEX (6-32) FEED ADJ	107
1	1	1	-	A	992031-1	PIN, CLEVIS	104
1	1	1	-	A	21009-2	SCR, 5LT 5ET (1/4-20x.25 LW) RAM	103
2	2	2	-	A	21017-2	SCR, DRIVE (#2x.19) ID PLATE	102
REF	REF	REF	-	A	6-23715-5	SCR, PAN HD (6-32x1.50) FEED ADJ	101
1	1	1	-	B	461264-1	PLATE, IDENTIFICATION	100
2	2	2	-	A	3-21002-0	SCR, BHC (10-32x.88) DRAG	99
1	1	1	-	A	22733-8	SCR, BHC (8-32x.38 LW) ANVIL	98
REF	REF	REF	-	A	2-21002-9	SCR, BHC (10-32x.75) CAP	97
REF	REF	REF	-	A	2-22733-8	SCR, BHC (1/4-20x.62) HOUSING	96
REF	REF	REF	-	A	2-21002-7	SCR, BHC (10-32x.50) 5G ADJ BLOCK	95
4	4	4	-	A	2-21002-2	SCR, BHC (8-32x.50) TERM H DWN	94
2	2	2	-	A	2-21002-3	SCR, BHC (8-32x.62) R STP GDE	93
1	1	1	-	A	1-21002-7	SCR, BHC (6-32x.38) CAM	91
1	1	-	-	A	7-21000-9	SCR, SHC (4-40x.19) STRIPPER	89
2	2	2	-	A	2-21000-7	SCR, SHC (8-32x.48) DEP-HOLD	87
1	1	1	-	A	2-22603-0	SCR, HEX HD (8-32x.31) FEED FINGER	86
2	2	2	-	A	1-21000-3	SCR, SHC (4-40x.25) F ST GUIDE	85
1	1	1	-	A	2-21000-7	SCR, SHC (8-32x.50) STRIPPER	84
REF	REF	REF	-	A	3-21000-7	SCR, SHC (10-32x.75) FEED ROD 6D	83
REF	REF	REF	-	A	3-21000-6	SCR, SHC (10-32x.62) FD ADJ BLK	82
1	1	1	-	A	3-21000-4	SCR, SHC (10-32x.38) 5G ADJ BL	81
REF	REF	REF	-	A	3-21000-4	SCR, SHC (10-32x.38) PIVOT BLK	80
-	REF	-	-	B	455749-1	GUARD, WINDOW	79
REF	-	-	-	B	679532-1	INSERT, GUARD	78
1	1	1	-	A	690603-1	SPRING, ASSIST	74
1	1	1	-	A	23030-1	SCR, SHC (6-32x.25 SL) INS DISC	73
REF	REF	REF	-	A	458109-1	WASHER, SPECIAL	72
REF	REF	REF	-	A	690517-1	SPACER	71

QTY	REF	REF	REF	REF	REF	DESCRIPTION	ITEM NO
1	1	1	-	A	690603-1	SPRING, ASSIST	74
1	1	1	-	A	23030-1	SCR, SHC (6-32x.25 SL) INS DISC	73
REF	REF	REF	-	A	458109-1	WASHER, SPECIAL	72
REF	REF	REF	-	A	690517-1	SPACER	71

QTY	REF	REF	REF	REF	REF	DESCRIPTION	ITEM NO
-1						LEADMAKER	
-2						BENCH MODEL K	
-3						BENCH MODEL G	
REF	REF	REF	-	B	22594-8	NUT, HEX (1/2-20)	70
REF	REF	REF	-	B	240628-1	PLATE, ADJUSTMENT	69
REF	REF	REF	-	B	240626-1	SHAFT, PIVOT	68
REF	REF	REF	-	B	240633-1	BUSHING	67
REF	REF	REF	-	A	455680-1	LEVER, INTERMEDIATE	66
REF	REF	REF	-	B	240629-1	BLOCK, PIVOT	65
REF	REF	REF	-	A	240632-2	SCREW, ADJ FEED ROD	64
REF	REF	REF	-	B	240659-3	PIN, CAM ROLLER	63
REF	REF	REF	-	B	240658-1	ROLLER, CAM	62
REF	REF	REF	-	B	454398-2	ROD, FEED	61
REF	REF	REF	-	A	454178-1	GUIDE, FEED ROD	60
REF	REF	REF	-	C	454220-1	CAP, RAM	59
REF	REF	REF	-	D	454485-1	HOUSING	58
1	1	1	-	B	1-694433-6	PAWL, FEED	56
REF	REF	REF	-	B	240624-1	PIN, FEED FINGER	55
REF	REF	REF	-	B	691499-1	SPRING, FEED FINGER	54
REF	REF	REF	-	B	690541-1	HOLDER, FEED FINGER	53
REF	REF	REF	-	A	455679-2	LEVER, TERMINAL FEED ARM	52
1	1	1	-	A	811242-2	BUMPER, HOLDDOWN	51
1	1	1	-	A	690753-1	SPACER, TONKER	50
1	-	-	-	B	690602-6	CAM, PRE-FEED 1 5/8 ST	49
-	1	-	-	B	690602-5	CAM, PRE-FEED 1 1/8 ST	48
-	-	1	-	B	690501-4	CAM, POST-FEED 1 5/8 ST	47
1	1	1	-	B	459456-2	APPLICATOR, BASIC (SUBASSY)	46
1	1	1	-	A	690191-1	PLUG, NYLON	45
1	1	1	-	C	819307-4	RAM	44
1	1	1	-	A	690125-1	WASHER, LAMINATED	43
1	1	1	-	A	690124-1	WASHER, RAM	42
1	1	1	-	A	690686-2	BOLT, CRIMPER (5/16x1.00)	41
1	1	1	-	A	23241-6	BALL, STEEL	40
1	1	1	-	A	690170-1	SPRING, COMPRESSION	39
1	1	1	-	C	690142-1	DISC, INSULATION	38
1	1	1	-	D	354777-1	WIRE DISC, PLASTIC	37
1	1	1	-	A	22480-5	WASHER, SPRING	36
1	1	1	-	B	690212-1	POST, RAM	35
1	1	1	-	B	690786-1	SUPPORT, TERMINAL	34
REF	REF	REF	-	D	455675-1	PLATE, BASE	33
1	1	1	-				32
1	1	1	-				31
REF	REF	REF	-	B	455689-1	BLOCK, STRIP GUIDE ADJ	30
1	1	1	-	C	318756-1	STRIP GUIDE PLATE ASSY	29
1	1	1	-	C	1-455888-5	SPACER, FRONT SHEAR DEP	28
2	2	2	-	A	1-22284-0	SPRING, DRAG	27
1	1	1	-	B	690546-1	LEVER, DRAG RELEASE	26
1	1	1	-	B	240792-1	DRAG, TERMINAL	25
1	1	1	-	D	6-690504-9	GUIDE, STRIP (REAR)	24
1	1	1	-	A	690438-1	GUIDE, STRIP (FRONT)	23
-	-	1	-	B	690472-2	STRIPPER	22
REF	REF	REF	-	A	4-22284-9	SPRING, FEED RETURN	21
1	1	-	-	A	679218-1	STRIPPER WIRE STOP ASSY	20
1	1	-	-	B	458949-1	STRIPPER	19
1	1	1	-	B	318563-1	GUARD, CHIP, FRONT	16
1	1	1	-				15
1	1	1	-	C	9-456135-4	CRIMPER, STABILIZER	14
1	1	1	-	A	5-22280-0	SPRING, SHEAR	12
1	1	1	-	B	690461-1	STOP, SHEAR	11
1	1	1	-	C	690459-1	HOLDER, SHEAR (FRONT)	10
1	1	1	-	C	454276-1	SHEAR, FLOAT (FRONT)	9
1	1	1	-	C	1213557-1	ANVIL	8
1	1	1	-				7
1	1	1	-	B	238011-2	SPACER, BLOCK CRIMPER	6
1	1	1	-	C	1-455889-4	DEPRESSOR, SHEAR (FRONT)	5
1	1	1	-	B	238011-7	SPACER, BLOCK CRIMPER	4
1	1	1	-	C	456134-5	CRIMPER, INSULATION	3
2	2	2	-	C	455888-4	SPACER, CRIMPER	2
1	1	1	-	C	1-456405-4	CRIMPER, WIRE	1