

PART NUMBER CODING
SBH51-LP E-D _-S _-BK

TERMINATION
M= SURFACE MOUNT W/O GUIDE POSTS
P= SURFACE MOUNT W/ GUIDE POSTS

NUMBER OF POSITIONS
(CONTACTS PER ROW, 03 THRU 50)

PLATING
.000030" - .000050" NICKEL UNDERPLATE,
P= GOLD FLASH OVERALL
S= .000010" GOLD OVERALL

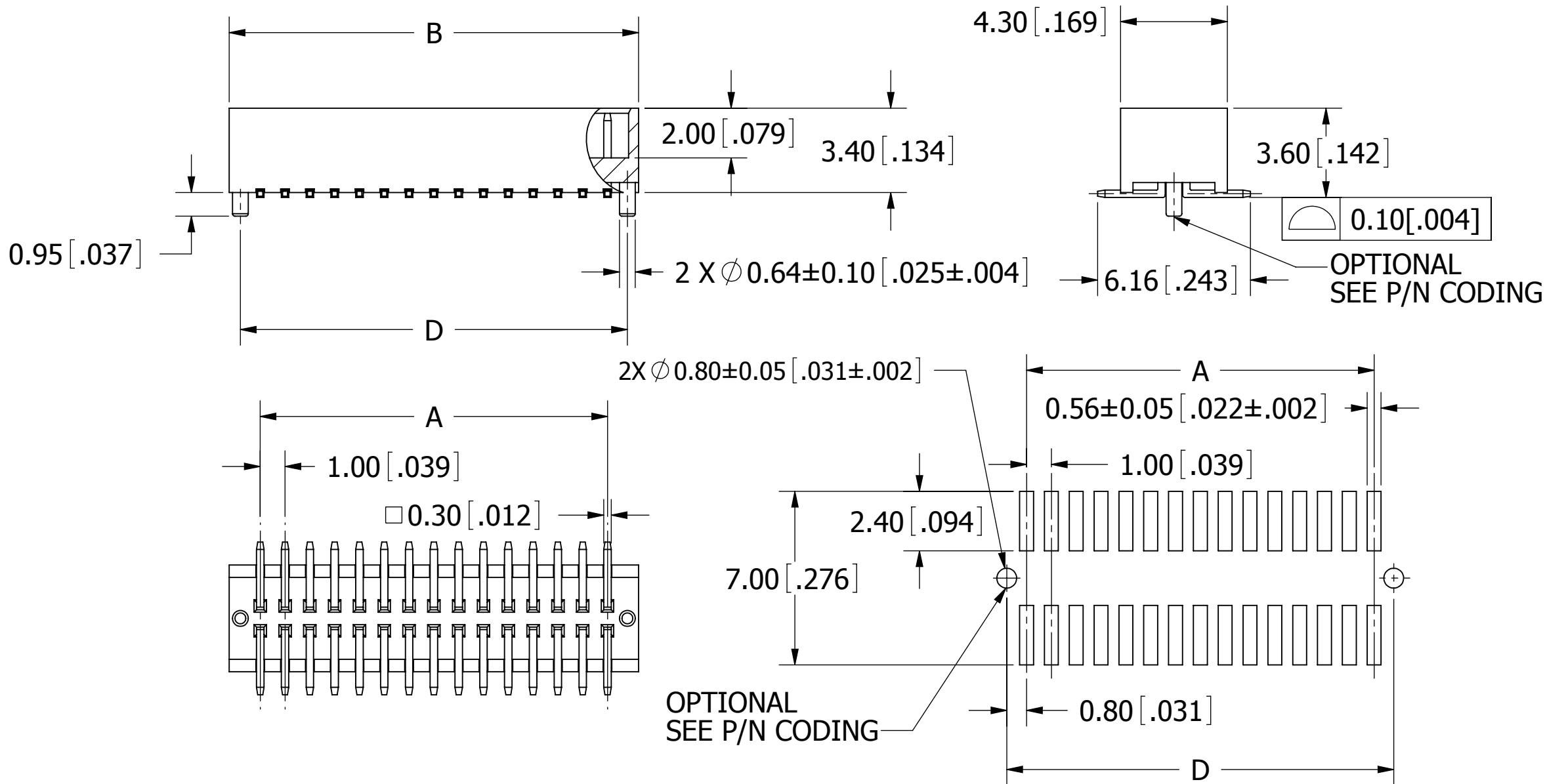
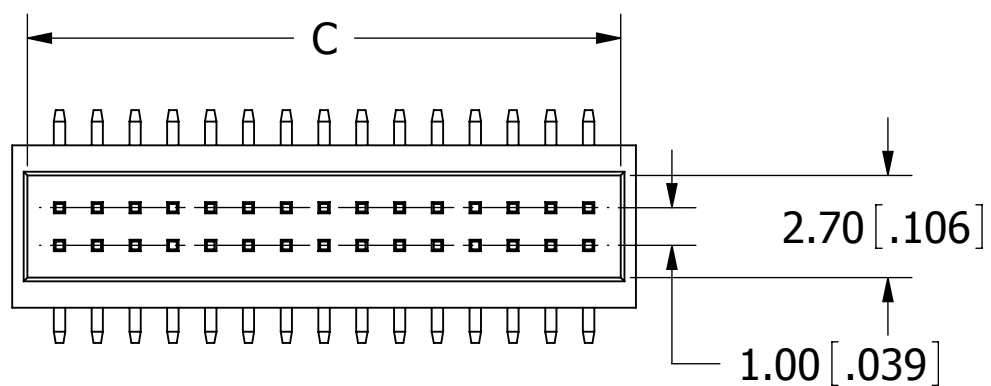
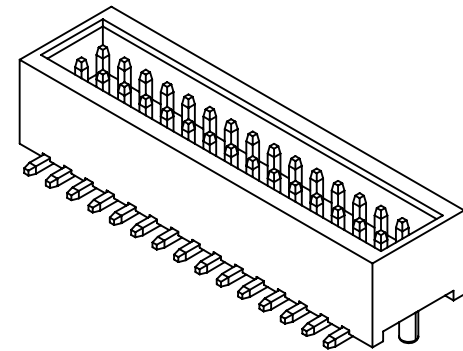

RECOMMENDED PCB LAYOUT

- NOTES:
- INSULATOR MATERIAL: LCP, UL 94V-0, BLACK.
 - CONTACT MATERIAL: PHOSPHOR BRONZE.
 - CONTACT PLATING: SEE PART NUMBER CODING.
 - CURRENT RATING: 1 AMP PER CONTACT.
 - INSULATOR RESISTANCE: 1000 MEGA OHMS MIN.
 - CONTACT RESISTANCE: 20 MILLIOHMS MAX.
 - DIELECTRIC WITHSTANDING: 300V AC.
 - OPERATING TEMPERATURE: -40° C TO +125° C.
 - *PROCESSING TEMP.: 230° C FOR 60 SECS MAX.
(260° C FOR 10 SECS MAX.)
 - MATES WITH SFM210 SERIES.

*INDICATED TEMPERATURE AND TIME IS FOR COMPONENT INSULATOR. HIGHER PROCESSING TEMPERATURES MAY BE USED, PROVIDED HEAT IS APPLIED FROM BACK SIDE OF PCB, AND INSULATOR DOES NOT EXCEED INDICATED TEMPERATURE AND TIME.

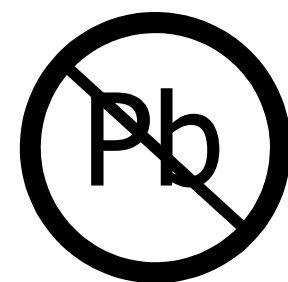

RoHS COMPLIANT

REVISIONS				
REV.	ECO. NO	DESCRIPTION	DATE	BY
A	2364	INITIAL RELEASE	06/08/2011	LH

PART NUMBER	POSITIONS/ CONTACTS	A		B		C		D		
		INCH	MM	INCH	MM	INCH	MM	INCH	MM	
SBH51-LP_E-D03-S_-BK	03/06	0.079	2.00	0.079	4.50	0.177	3.70	0.146	3.60	0.142
SBH51-LP_E-D04-S_-BK	04/08	0.118	3.00	0.118	5.50	0.217	4.70	0.185	4.60	0.181
SBH51-LP_E-D05-S_-BK	05/10	0.157	4.00	0.157	6.50	0.256	5.70	0.224	5.60	0.220
SBH51-LP_E-D06-S_-BK	06/12	0.197	5.00	0.197	7.50	0.295	6.70	0.264	6.60	0.260
SBH51-LP_E-D07-S_-BK	07/14	0.236	6.00	0.236	8.50	0.335	7.70	0.303	7.60	0.299
SBH51-LP_E-D08-S_-BK	08/16	0.276	7.00	0.276	9.50	0.374	8.70	0.343	8.60	0.339
SBH51-LP_E-D09-S_-BK	09/18	0.315	8.00	0.315	10.50	0.413	9.70	0.382	9.60	0.378
SBH51-LP_E-D10-S_-BK	10/20	0.354	9.00	0.354	11.50	0.453	10.70	0.421	10.60	0.417
SBH51-LP_E-D11-S_-BK	11/22	0.394	10.00	0.394	12.50	0.492	11.70	0.461	11.60	0.457
SBH51-LP_E-D12-S_-BK	12/24	0.433	11.00	0.433	13.50	0.531	12.70	0.500	12.60	0.496
SBH51-LP_E-D13-S_-BK	13/26	0.472	12.00	0.472	14.50	0.571	13.70	0.539	13.60	0.535
SBH51-LP_E-D14-S_-BK	14/28	0.512	13.00	0.512	15.50	0.610	14.70	0.579	14.60	0.575
SBH51-LP_E-D15-S_-BK	15/30	0.551	14.00	0.551	16.50	0.650	15.70	0.618	15.60	0.614
SBH51-LP_E-D16-S_-BK	16/32	0.591	15.00	0.591	17.50	0.689	16.70	0.657	16.60	0.654
SBH51-LP_E-D17-S_-BK	17/34	0.630	16.00	0.630	18.50	0.728	17.70	0.697	17.60	0.693
SBH51-LP_E-D18-S_-BK	18/36	0.669	17.00	0.669	19.50	0.768	18.70	0.736	18.60	0.732
SBH51-LP_E-D19-S_-BK	19/38	0.709	18.00	0.709	20.50	0.807	19.70	0.776	19.60	0.772
SBH51-LP_E-D20-S_-BK	20/40	0.748	19.00	0.748	21.50	0.846	20.70	0.815	20.60	0.811
SBH51-LP_E-D21-S_-BK	21/42	0.787	20.00	0.787	22.50	0.886	21.70	0.854	21.60	0.850
SBH51-LP_E-D22-S_-BK	22/44	0.827	21.00	0.827	23.50	0.925	22.70	0.894	22.60	0.890
SBH51-LP_E-D23-S_-BK	23/46	0.866	22.00	0.866	24.50	0.965	23.70	0.933	23.60	0.929
SBH51-LP_E-D24-S_-BK	24/48	0.906	23.00	0.906	25.50	1.004	24.70	0.972	24.60	0.969
SBH51-LP_E-D25-S_-BK	25/50	0.945	24.00	0.945	26.50	1.043	25.70	1.012	25.60	1.008
SBH51-LP_E-D26-S_-BK	26/52	0.984	25.00	0.984	27.50	1.083	26.70	1.051	26.60	1.047
SBH51-LP_E-D27-S_-BK	27/54	1.024	26.00	1.024	28.50	1.122	27.70	1.091	27.60	1.087
SBH51-LP_E-D28-S_-BK	28/56	1.063	27.00	1.063	29.50	1.161	28.70	1.130	28.60	1.126
SBH51-LP_E-D29-S_-BK	29/58	1.102	28.00	1.102	30.50	1.201	29.70	1.169	29.60	1.165
SBH51-LP_E-D30-S_-BK	30/60	1.142	29.00	1.142	31.50	1.240	30.70	1.209	30.60	1.205
SBH51-LP_E-D31-S_-BK	31/62	1.181	30.00	1.181	32.50	1.280	31.70	1.248	31.60	1.244
SBH51-LP_E-D32-S_-BK	32/64	1.220	31.00	1.220	33.50	1.319	32.70	1.287	32.60	1.283
SBH51-LP_E-D33-S_-BK	33/66	1.260	32.00	1.260	34.50	1.358	33.70	1.327	33.60	1.323
SBH51-LP_E-D34-S_-BK	34/68	1.299	33.00	1.299	35.50	1.398	34.70	1.366	34.60	1.362
SBH51-LP_E-D35-S_-BK	35/70	1.339	34.00	1.339	36.50	1.437	35.70	1.406	35.60	1.402
SBH51-LP_E-D36-S_-BK	36/72	1.378	35.00	1.378	37.50	1.476	36.70	1.445	36.60	1.441
SBH51-LP_E-D37-S_-BK	37/74	1.417	36.00	1.417	38.50	1.516	37.70	1.484	37.60	1.480
SBH51-LP_E-D38-S_-BK	38/76	1.457	37.00	1.457	39.50	1.555	38.70	1.524	38.60	1.520
SBH51-LP_E-D39-S_-BK	39/78	1.496	38.00	1.496	40.50	1.594	39.70	1.563	39.60	1.559
SBH51-LP_E-D40-S_-BK	40/80	1.535	39.00	1.535	41.50	1.634	40.70	1.602	40.60	1.598
SBH51-LP_E-D41-S_-BK	41/82	1.575	40.00	1.575	42.50	1.673	41.70	1.642	41.60	1.638
SBH51-LP_E-D42-S_-BK	42/84	1.614	41.00	1.614	43.50	1.713	42.70	1.681	42.60	1.677
SBH51-LP_E-D43-S_-BK	43/86	1.654	42.00	1.654	44.50	1.752	43.70	1.720	43.60	1.717
SBH51-LP_E-D44-S_-BK	44/88	1.693	43.00	1.693	45.50	1.791	44.70	1.760	44.60	1.756
SBH51-LP_E-D45-S_-BK	45/90	1.732	44.00	1.732	46.50	1.831	45.70	1.799	45.60	1.795
SBH51-LP_E-D46-S_-BK	46/92	1.772	45.00	1.772	47.50	1.870	46.70	1.839	46.60	1.835
SBH51-LP_E-D47-S_-BK	47/94	1.811	46.00	1.811	48.50	1.909	47.70	1.878	47.60	1.874
SBH51-LP_E-D48-S_-BK	48/96	1.850	47.00	1.850	49.50	1.949	48.70	1.917	48.60	1.913
SBH51-LP_E-D49-S_-BK	49/98	1.890	48.00	1.890	50.50	1.988	49.70	1.957	49.60	1.953
SBH51-LP_E-D50-S_-BK	50/100	1.929	49.00	1.929	51.50	2.028	50.70	1.996	50.60	1.992

UNLESS OTHERWISE SPECIFIED: DIMENSIONS ARE IN MM(INCHES)	DRAWN	DATE	NAME	
		06/08/2011	LH	
TOLERANCES: ANGULAR: .X=± .3 [.01] .XX=± .20 [.008] .XXX=± .100 [.0040]	THE INFORMATION HEREIN CONTAINS PROPRIETARY INFORMATION OF SULLINS ELECTRONICS AND IS NOT TO BE REPRODUCED, USED OR DISCLOSED TO OTHERS FOR ANY PURPOSE EXCEPT AS SPECIFICALLY AUTHORIZED IN WRITING BY AN OFFICER OF SULLINS ELECTRONICS.			TITLE BOX HEADER, 1.00mm [.039"] CC/RS, SMT
INTERPRET DIMENSIONS AND TOLERANCING PER: ASME Y14.5M-2009				PART NUMBER SBH51-LP_E-D _-S _-BK
	SIZE C	CAGE CODE 54453	DWG. NO. 11775	REV A
	SCALE: 5:1			SHEET 1 OF 1