

Number of contacts

# 5-21



Mixed shells with pre-mounted signal solder cup contacts

Identification	No. of contacts <sup>1)</sup>	Part number			
		male connectors		female connectors	
		Performance level 3	S4 <sup>2)</sup>	Performance level 3	S4 <sup>2)</sup>
	5W1	09 69 111 7051	09 69 111 5051	09 69 101 7051	09 69 101 5051
	11W1	09 69 211 7111	09 69 211 5111	09 69 201 7111	09 69 201 5111
	21W1	09 69 311 7211	09 69 311 5211	09 69 301 7211	09 69 301 5211

Male connectors

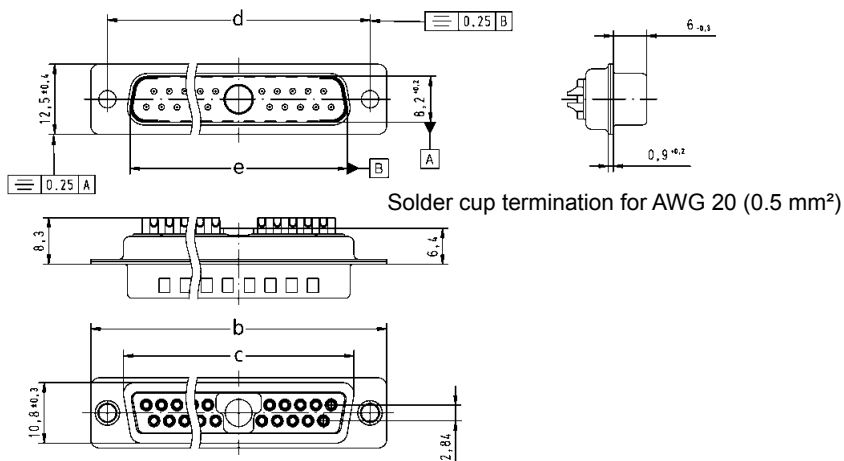

Female connectors

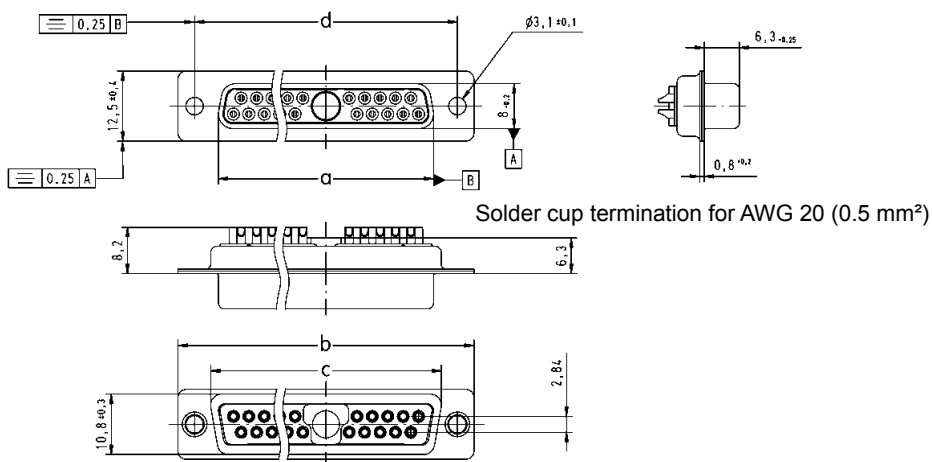

	a	b	c	d	e
5W1	16.4	30.8	19.3	25.00	16.9
11W1	24.7	39.1	27.5	33.30	25.2
21W1	38.5	53.0	41.3	47.04	38.9

Dimensions in mm

<sup>1)</sup> Explanations see page 05.51  
<sup>2)</sup> S4 = 0.76 µm Au or PdNi equivalent  
 Board drillings see pages 05.78 ff

Order special contacts separately. See pages 05.69 ff