

NOTES 1. The dimension in parentheses are for reference.

2. Lead co-planarity including reinforced chucking metals shall be 0.1 max.

3. To be delivered with tape and reel packages.

4. Note that preventive hole for sink mark or slit could be added for improvement.

5. The quality remains good, even with the dark spots, which could occasionally occur on molded plastic.

6. This product satisfies halogen free requirements defined as 900ppm maximum chlorine, 900ppm maximum bromine, and 1500ppm maximum total of chlorine and bromine.

7. Shows hook part of the chucking metal.

FORM HCO011-5-7

2

3

4

5

6

7

8

F

E

D

C

B

A

1

2

3

4

5

6

7

8

9

10

11

12

13

14

15

16

17

18

19

20

21

22

23

24

25

26

27

28

29

30

31

32

33

34

35

36

37

38

39

40

41

42

43

44

45

46

47

48

49

50

51

52

53

54

55

56

57

58

59

60

61

62

63

64

65

66

67

68

69

70

71

72

73

74

75

76

77

78

79

80

81

82

83

84

85

86

87

88

89

90

91

92

93

94

95

96

97

98

99

100

101

102

103

104

105

106

107

108

109

110

111

112

113

114

115

116

117

118

119

120

121

122

123

124

125

126

127

128

129

130

131

132

133

134

135

136

137

138

139

140

141

142

143

144

145

146

147

148

149

150

151

152

153

154

155

156

157

158

159

160

161

162

163

164

165

166

167

168

169

170

171

172

173

174

175

176

177

178

179

180

181

182

183

184

185

186

187

188

189

190

191

192

193

194

195

196

197

198

199

200

201

202

203

204

205

206

207

208

209

210

211

212

213

214

215

216

217

218

219

220

221

222

223

224

225

226

227

228

229

230

231

232

233

234

235

236

237

238

239

240

241

242

243

244

245

246

247

248

249

250

251

252

253

254

255

256

257

258

259

260

261

262

263

264

265

266

267

268

269

270

271

272

273

274

275

276

277

278

279

280

281

282

283

RECOMMENDED FPC (20:1)
 (Exposed conductor area thickness: t=0.12±0.02)

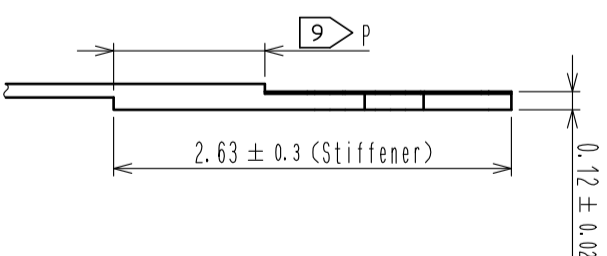
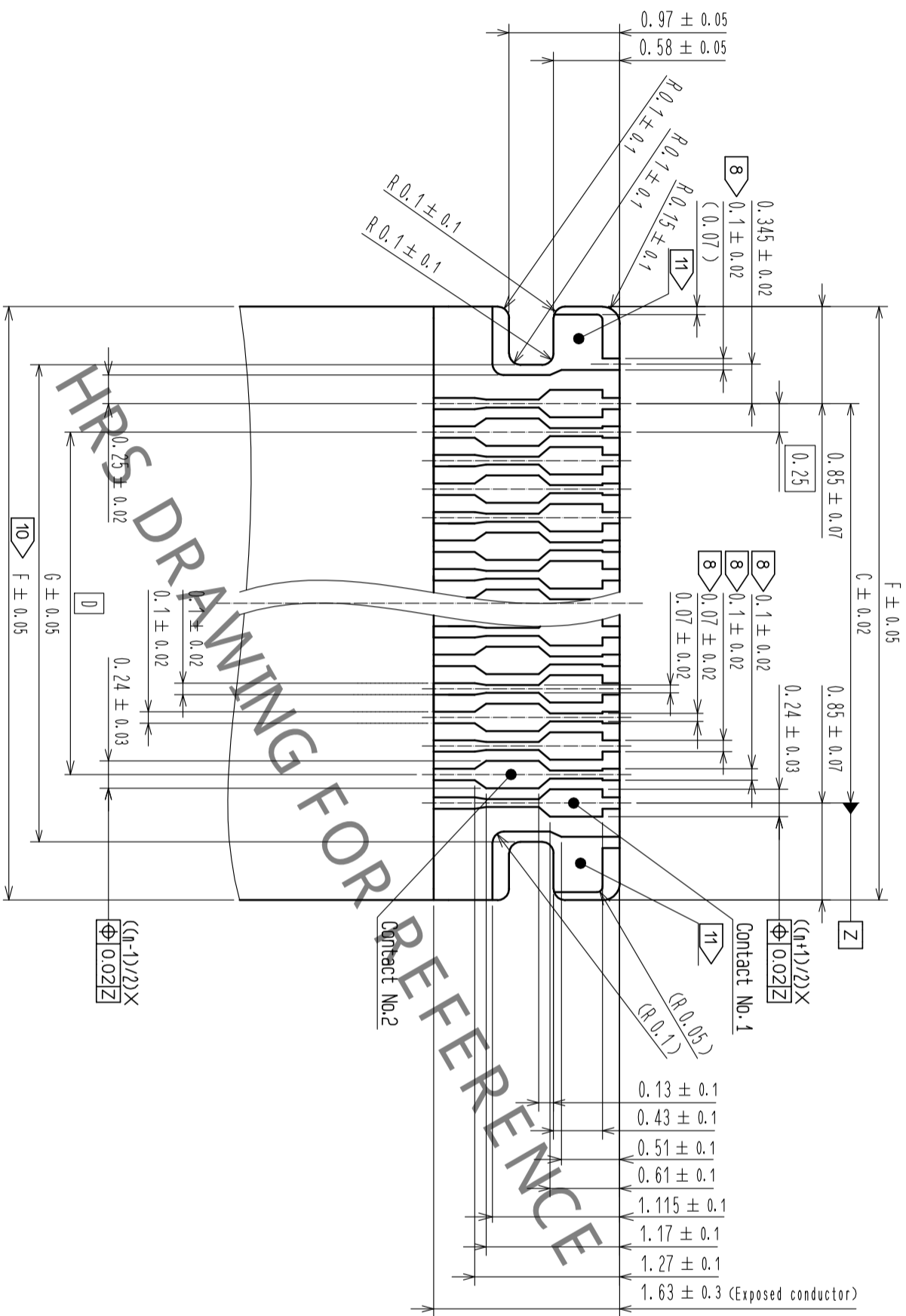

FPC CONFIGURATION (REFERENCE EXAMPLE)
 (FREE)

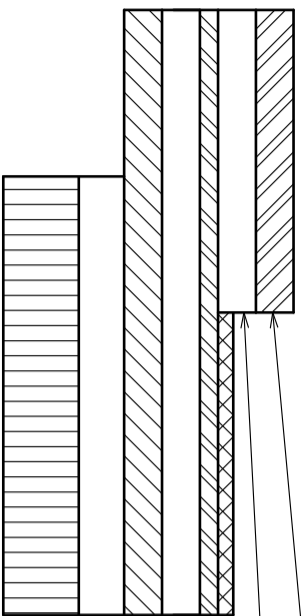

MATERIAL NAME	MATERIAL	THICKNESS (μm)
Covering film layer.	Polyimide 1mil	25
Cover adhesive		25
Surface treatment	1μm to 6μm nickel underplated 0.2μm gold plated	(4)
Copper foil	Cu 1/2 oz	18
Base adhesive	Heat-hardened adhesive	No adhesion material
Base film	Polyimide 1mil	25
Reinforcement material adhesive	Heat-hardened adhesive	30
Stiffener	Polyimide 2mil	50

NOTES 8 Shows recommended dimension when lead for plating is required.

9 Dimension P must be 0.5mm minimum.

10 Indicated tolerance is applicable to the exposed conductor.

11 Both end side of contact pad on FPC can not be used for signal transmission.

12 Recommended puncher direction: From conductor side to stiffener side.

<RECOMMENDED FPC>

HR5	DRAWING NO.	EDC-375451-00-00
	PART NO.	FH64MA-**-S-0.25SHW
	CODE NO.	CL580-

EMBOSSED CARRIER TAPE DIMENSION
 (5:1)

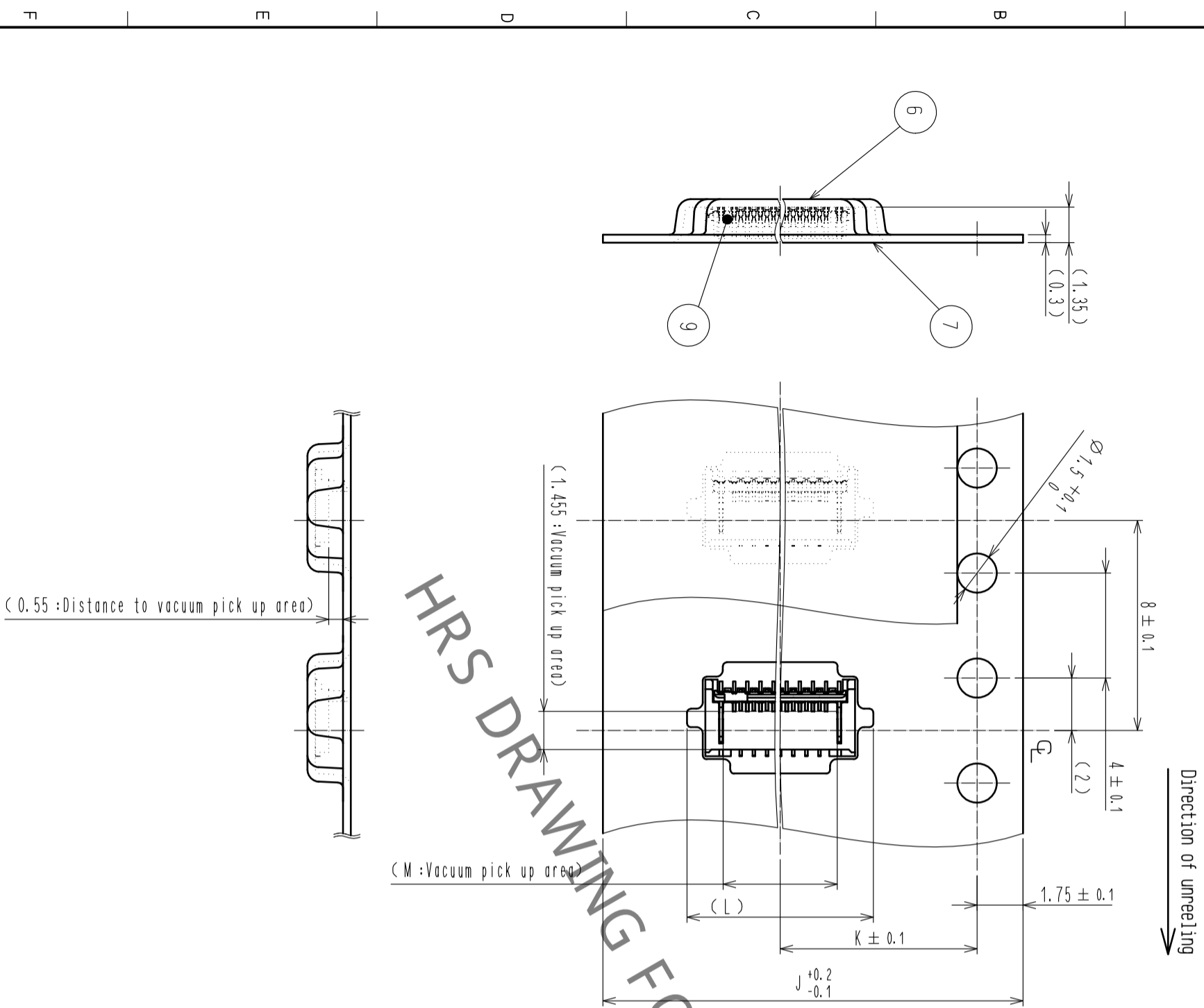

REEL DIMENSION
 (FREE)

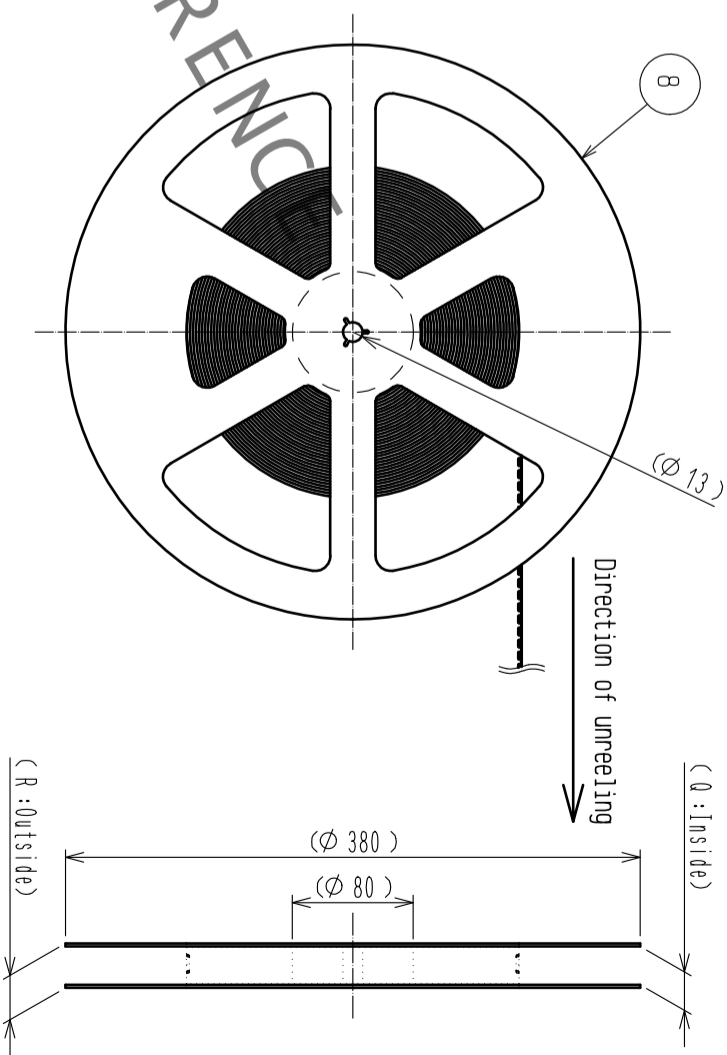

LEADER, TRAILER DIMENSION
 (FREE)

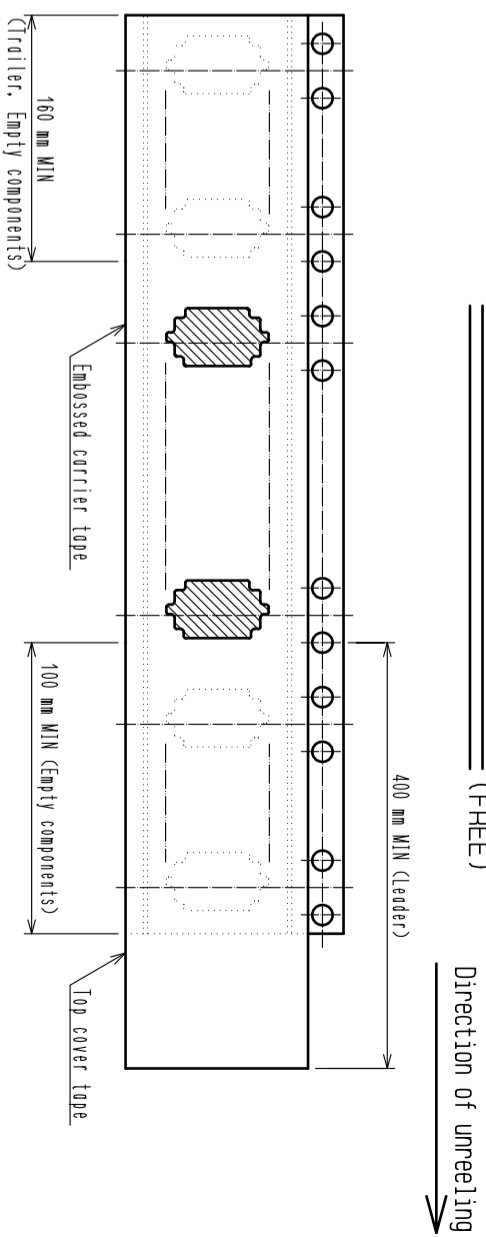

- NOTES 13. Per reel : 5000 connectors.
 14. Refer to JIS C 0806 and IEC 60286-3
 (Packaging of components for automatic handling.)

< PACKING SPECIFICATIONS >

HRS	DRAWING NO.	EDC-375451-00-00
	PART NO.	FH64MA-**-S-0.25SHW
	CODE	CL580-

PART NUMBER	CODE NUMBER	NUMBER OF CONTACTS	DIMENSION OF CONNECTOR, PCB MOUNTING PATTERN, STENCIL PATTERN, FPC										DIMENSION OF DRAWING FOR PACKING					
			A	B	C	D	E	F	G	J	K	L	M	Q	R			
FH64MA-5S-0.25SHW	CL580-4643-0-00	5	3.2	2	1	0.5	2.73	2.7	1.68	16	7.5	4.6	1.86	17.4	21.4			
FH64MA-7S-0.25SHW	CL580-4610-0-00	7	3.7	2.5	1.5	1	3.23	3.2	2.18	16	7.5	5.1	2.36	17.4	21.4			
FH64MA-9S-0.25SHW	-	9	4.2	3	2	1.5	3.73	3.7	2.68	16	7.5	5.6	2.86	17.4	21.4			
FH64MA-11S-0.25SHW	CL580-4612-0-00	11	4.7	3.5	2.5	2	4.23	4.2	3.18	16	7.5	6.1	3.36	17.4	21.4			
FH64MA-13S-0.25SHW	-	13	5.2	4	3	2.5	4.73	4.7	3.68	16	7.5	6.6	3.86	17.4	21.4			
FH64MA-15S-0.25SHW	CL580-4608-0-00	15	5.7	4.5	3.5	3	5.23	5.2	4.18	16	7.5	7.1	4.36	17.4	21.4			
FH64MA-17S-0.25SHW	-	17	6.2	5	4	3.5	5.73	5.7	4.68	16	7.5	7.6	4.86	17.4	21.4			
FH64MA-19S-0.25SHW	CL580-4616-0-00	19	6.7	5.5	4.5	4	6.23	6.2	5.18	16	7.5	8.1	5.36	17.4	21.4			
FH64MA-21S-0.25SHW	-	21	7.2	6	5	4.5	6.73	6.7	5.68	24	11.5	8.6	5.86	25.4	29.4			
FH64MA-23S-0.25SHW	-	23	7.7	6.5	5.5	5	7.23	7.2	6.18	24	11.5	9.1	6.36	25.4	29.4			
FH64MA-25S-0.25SHW	CL580-4642-0-00	25	8.2	7	6	5.5	7.73	7.7	6.68	24	11.5	9.6	6.86	25.4	29.4			
FH64MA-31S-0.25SHW	-	31	9.7	8.5	7.5	7	9.23	9.2	8.18	24	11.5	11.1	8.36	25.4	29.4			
FH64MA-35S-0.25SHW	-	35	10.7	9.5	8.5	8	10.23	10.2	9.18	24	11.5	12.1	9.36	25.4	29.4			
FH64MA-37S-0.25SHW	-	37	11.2	10	9	8.5	10.73	10.7	9.68	24	11.5	12.6	9.86	25.4	29.4			
FH64MA-41S-0.25SHW	-	41	12.2	11	10	9.5	11.73	11.7	10.68	24	11.5	13.6	10.86	25.4	29.4			

HRS DRAWING FOR REFERENCE

※ CONTACT POSITIONS WITHOUT CODE NUMBERS ARE CURRENTLY UNDER PLANNING.
PLEASE CONTACT HIROSE FOR DETAILED INFORMATION ABOUT PRODUCT VARIATION.

<DIMENSION TABLE>

DRAWING NO.	EDC-375451-00-00
PART NO.	FH64MA-**-S-0.25SHW
CODE NO.	CL580-



This connector features small and thin, requiring delicate and careful handling.
 To prevent connector/FPC breakage and contact failure (mating failure, FPC pattern breakage, etc.),
 read through the instructions shown below and handle the connector properly.

Connector Part Nomenclature

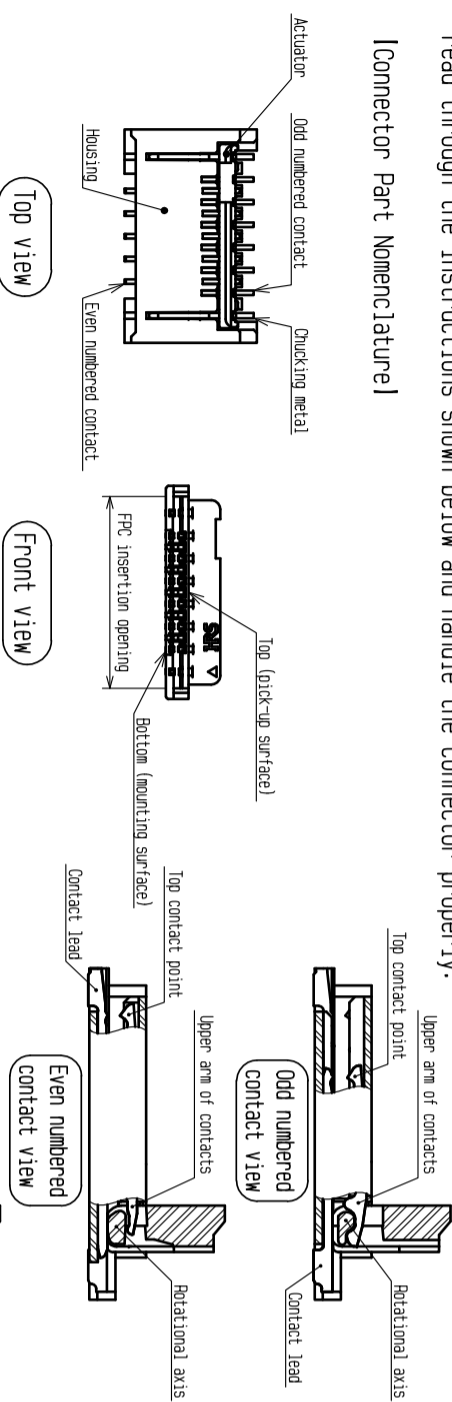

Operation and Precautions

1. Initial condition

Actuator does not have to be operated before inserting FPC, as the connector is delivered with the actuator opened.

[Caution]

- Do not close the actuator before inserting FPC. Closing the actuator without FPC could make the contact gap smaller, which could increase the FPC insertion force. (Example1)
- Do not insert FPC or operate actuator before mounting. (Example1)

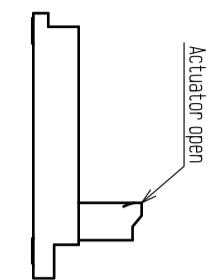

Example1

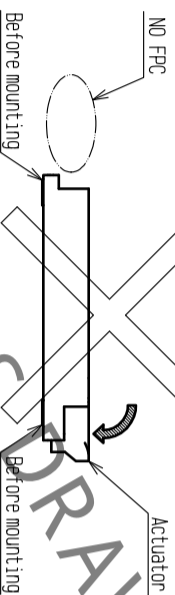

DRAWING FOR REFERENCE

3. FPC insertion check

Make sure that the FPC tabs are located in proper position as shown in the figure below after FPC insertion. (Example5)

[Caution]

- Do not insert the FPC at an angle and/or stop it before insertion is completed. (Example6) (Example7)

Examples

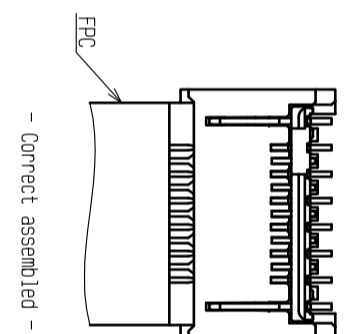

Example5

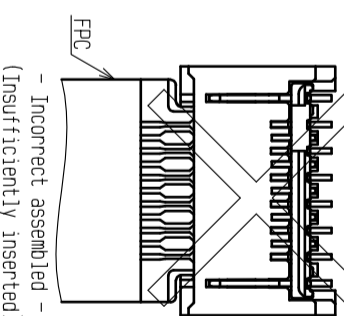

Example6

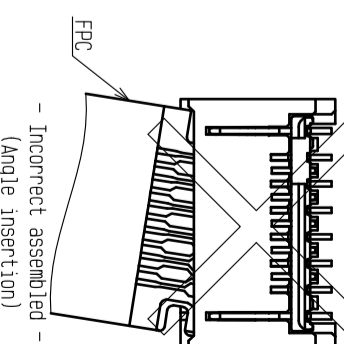

Example7

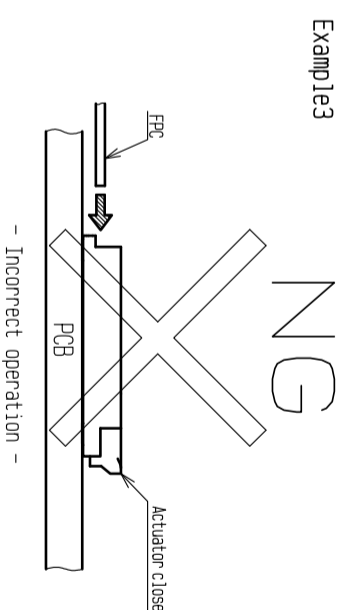

Example3

Example4

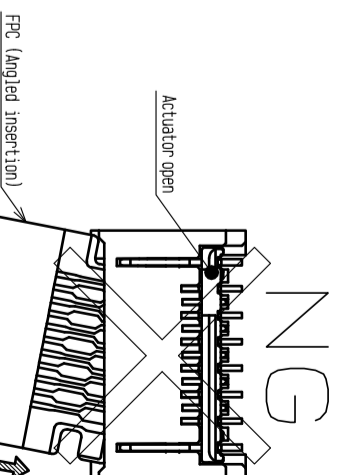
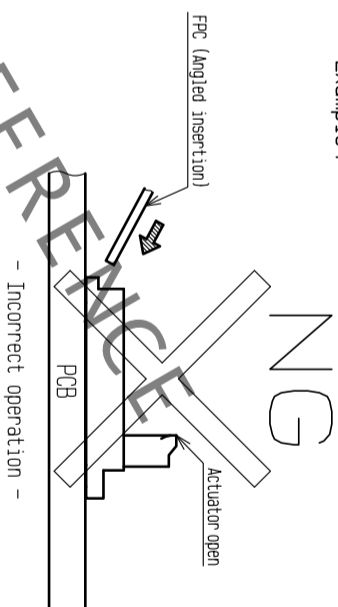

2. How to insert FPC

Insert the FPC into the connector opening horizontally to the PCB plane. Insert it properly to the very end. (Example2)

[Caution]

- Do not insert the FPC with the actuator closed. (Example3)
- Do not twist the FPC to up and down, right and left or an angle. (Example4)

Example2

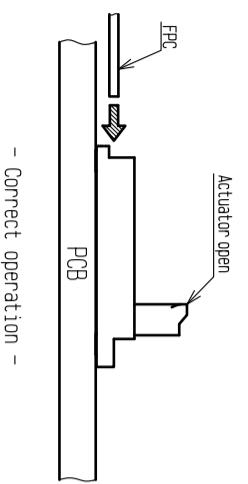

OK

OK

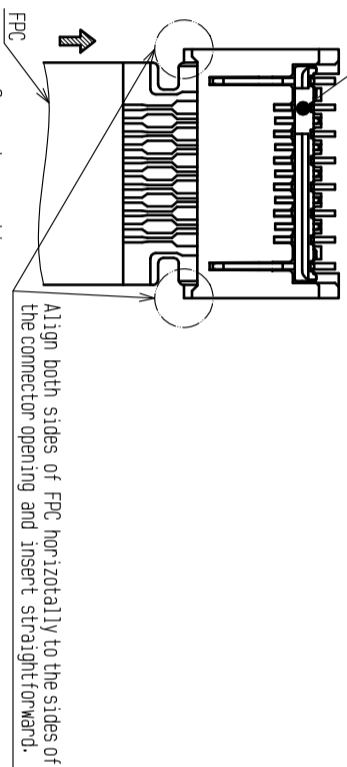

OK

Align both sides of FPC horizontally to the sides of the connector opening and insert straightforward.

INSTRUCTION MANUAL (1)

HR5	
DRAWING NO.	EDC-375451-00-00
PART NO.	FH64MA-**-S-0.25SHW
CODE NO.	CL580-

4. How to lock

The actuator rotates around the rotational axis as shown below.
 Apply load to rotate the actuator by 90 degree after inserting the FPC. (Example18)

- [Caution]
- To close the actuator, operate at the center of the actuator. (Example19)
 - To close the actuator, do not operate the actuator at one end only. (Example10)
 - The actuator rotates 90 degrees max. Do not try to rotate the actuator further towards the opening direction or apply any extra force to the actuator while it is fully open. (Example11)
 - Do not apply extra force to the connector while the upper rotating the actuator as the illustration shows. (Example 12, 13)
 - Do not operate the actuator while the upper contact arm is pressed down. (Example14)
 - Do not pick the actuator to lift. (Example15)
 - operate the actuator by hand without using sharp tool such as Tweezers. (Example16)
 - Do not apply excess force to the housing during the operation. (Example17)

Example18 [Actuator movable range] (Side view)

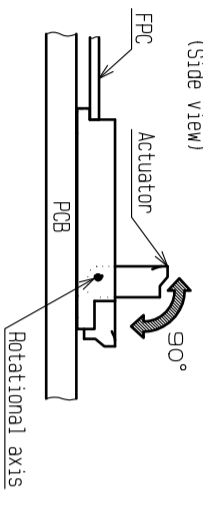

Example9 OK

Close the actuator at the center

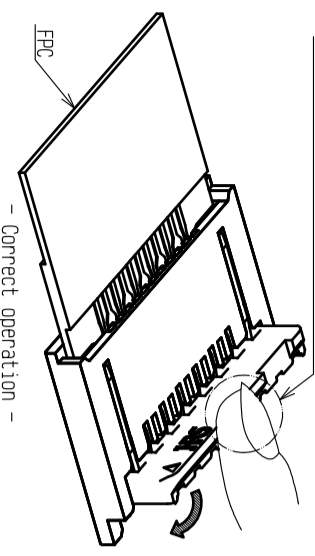

- Correct operation -

Example11 NNG

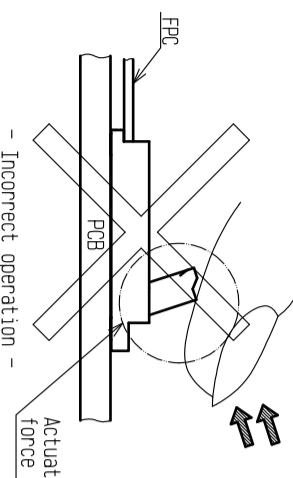

- Incorrect operation -

Example13 NNG

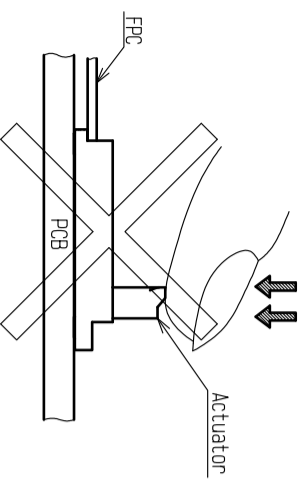

- Incorrect operation -

Example10 NNG

Do not operate the actuator at one end only

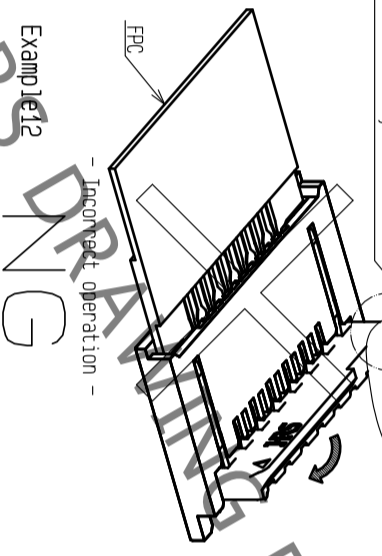

- Incorrect operation -

Example12 NNG

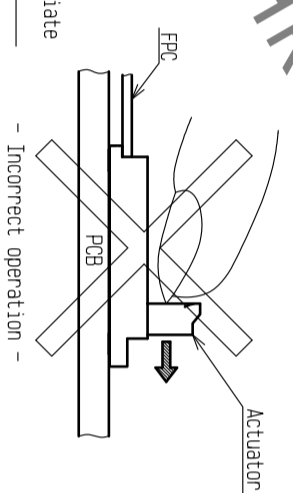

- Incorrect operation -

Example14 NNG

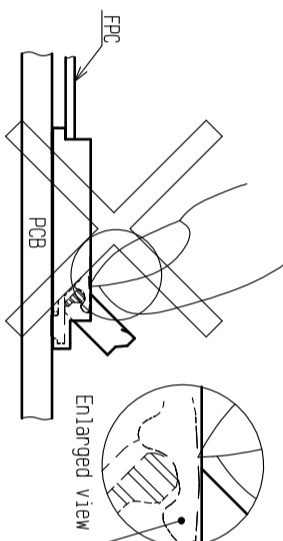

- Incorrect operation -

Example15 NNG

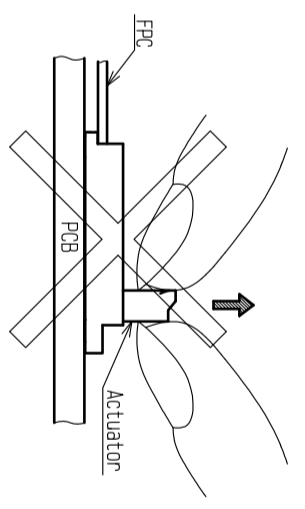

- Incorrect operation -

Example16 NNG

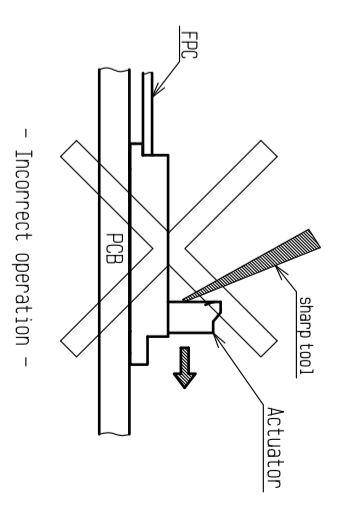

- Incorrect operation -

Example17 NNG

Do not apply excess force to the housing during the operation.

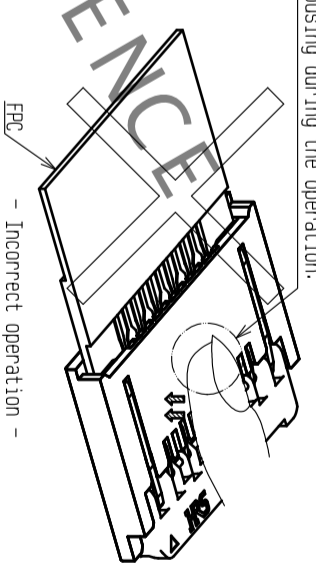

- Incorrect operation -

5. Mating confirmation of the FPC

Visually confirm the FPC positioning after closing the actuator. (Example18)

[Caution]

-Do not insert the FPC at an angle and/or stop it before insertion is completed. (Example19)(Example20)

Example18 OK

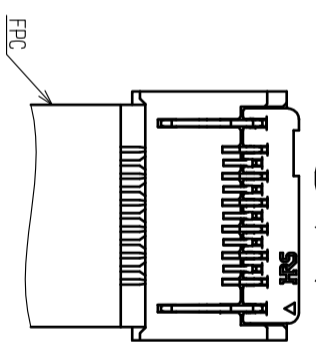

- Correct assembled -

Example19 NNG

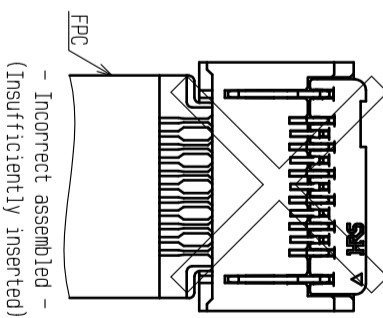

- Incorrect assembled - (Insufficiently inserted)

Example20 NNG

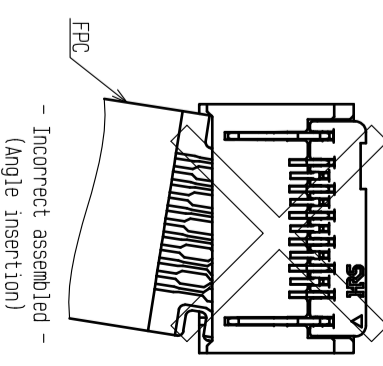

- Incorrect assembled - (Angle insertion)

< INSTRUCTION MANUAL (2) >

HRS

DRAWING NO.	EDC-375451-00-00
PART NO.	FH64MA-**-S-0.25SHW
CODE	CL580-

6. How to unlock

Slowly flip up the actuator to release the lock. (Example21)

[Caution]

- To open the actuator, operate at the center of the actuator. (Example22)
- To open the actuator, do not operate the actuator at one end only. (Example23)
- The actuator rotates 90 degrees max.
- Do not try to rotate the actuator further towards the opening direction or apply any extra force to the actuator while it is fully open. (Example24)
- Open the actuator right above.
- Do not attempt to open further or to open it by applying horizontal force as this may cause its damage. (Example25)
- Do not pick the actuator to lift. (Example26)
- Operate the actuator by hand without using sharp tool such as Tweezers. (Example27)
- Do not apply excess force to the housing during the operation. (Example28)
- Please note that the connector is back flip style connector, and the opening for FPC insertion and the actuator face the opposite direction. Do not try to lift the actuator at the FPC insertion opening side. (Example29)

Example21

OK

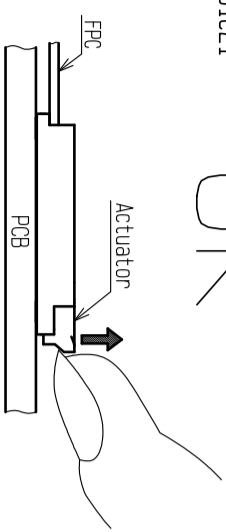

Example22

OK

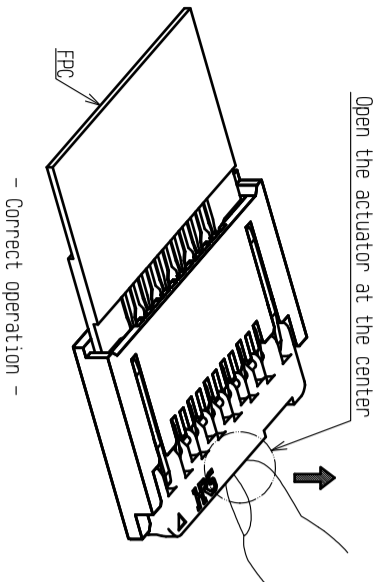

Example23

Do not operate the actuator at one end only

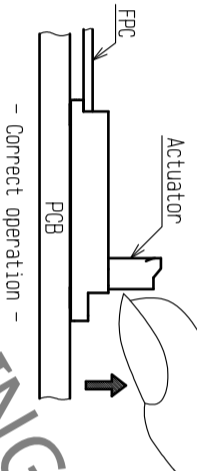

Example24

NG

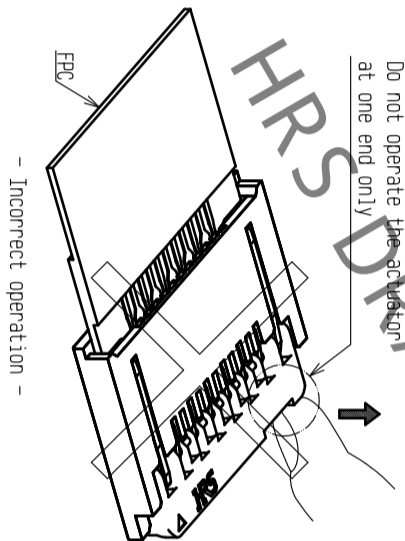

Example25

NG

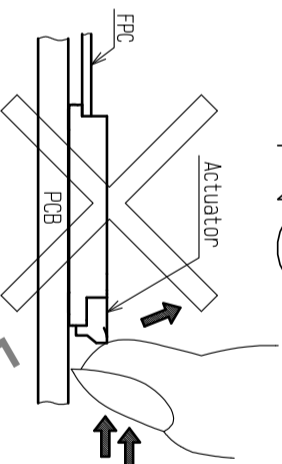

Example26

NG

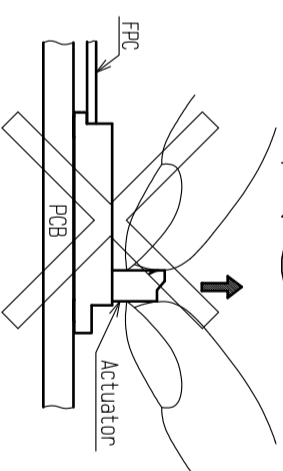

Example28

NG

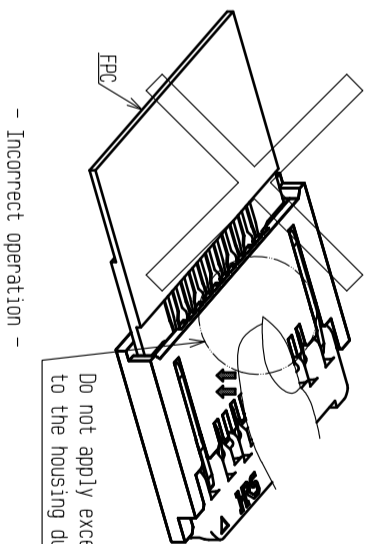

Example27

NG

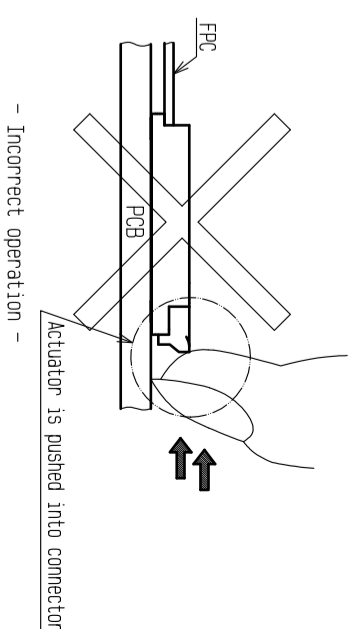

Example29

NG

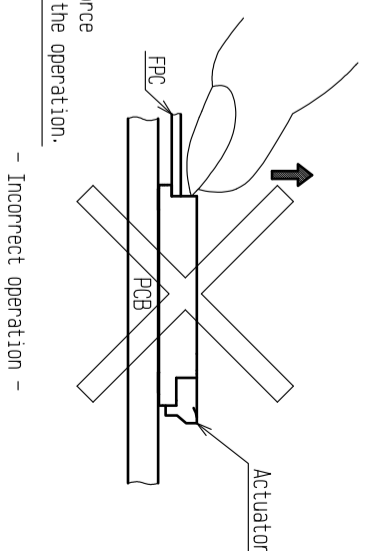

< INSTRUCTION MANUAL (3) >

HRS	
DRAWING NO.	EDC-375451-00-00
PART NO.	FH64MA-**-S-0.25SHW
CODE	CL580-

HRS DRAWING FOR REFERENCE

7. How to remove FPC
 After rotating the actuator to the fully opened position carefully withdraw the FPC pulling out horizontally. (Example30)

[Caution]
 -Do not withdraw the FPC at inclined towards vertical and horizontal angle. (Example31)
 -Do not attempt to pull the FPC without unlocking the actuator (Example32).

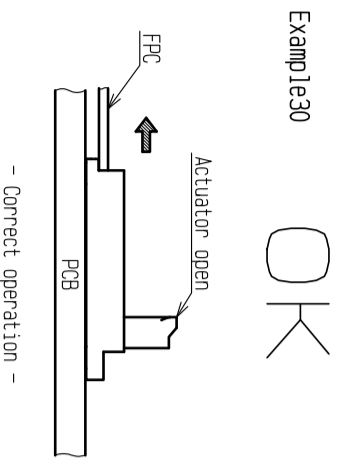

Example30

OK

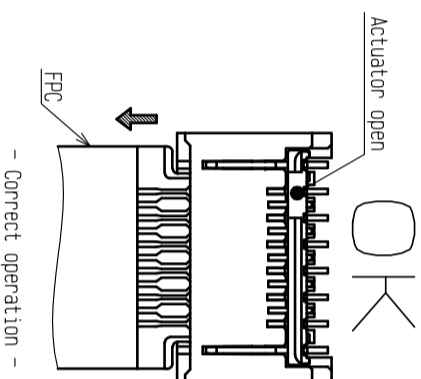

OK

Example31

NG

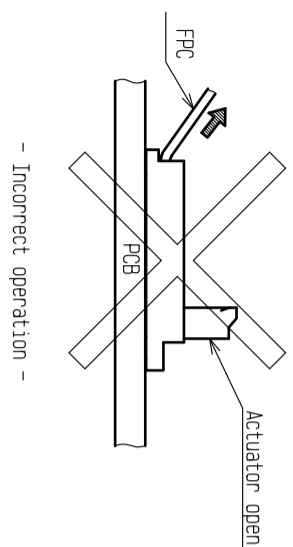

NG

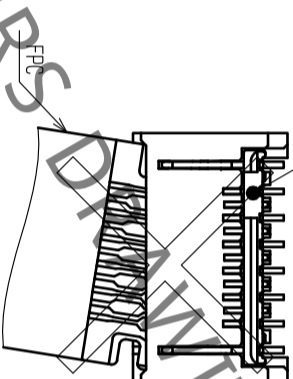

Example32

NG

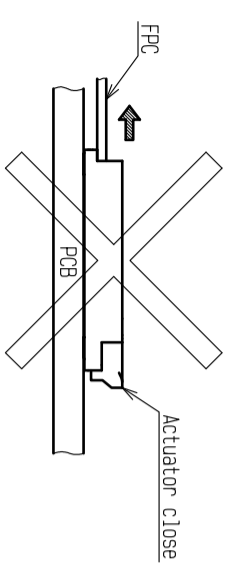

NG

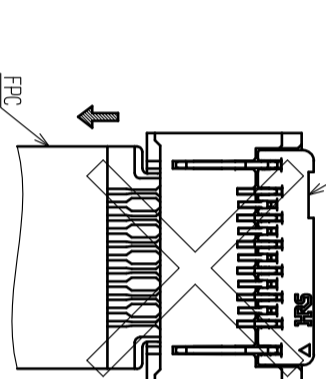

[Precautions for component layout]
 While the FPC is under tension due to the connecting configuration, extra stress may be applied to the connector. As a result, conduction failure may occur due to the extra stress. In order to prevent such kind of conduction failure, please read through the following parts before making circuits/mechanism design.

[Caution]
 -Avoid applying forces to/pulling the FPC along/perpendicular to the direction of FPC insertion. (Example 33)
 -Avoid pushing/pulling the FPC upwards/downwards.
 -If the FPC has to be curled/bended in your cabling design, please keep enough degree of freedom in your design to keep the FPC tension free.
 -In this regard, the stiffener should be parallel to the PCB. (Example 34)
 -If the FPC has to be curled/bended in your cabling design, do not curl/bend the FPC area near the connector. This may lead to conduction failure or FPC breakage. (Example 35)
 -It is recommended to keep the FPC fixed to avoid applying stress through the FPC to the connector.
 -Do not mount other components underneath the FPC stiffener which may interfere with the connection. (Example 36)
 -Follow the recommended FPC design.
 -Please consult with the FPC manufacturer about FPC bending performance and wire breakage strength while making design.
 -Keep sufficient operating space for FPC insertion during layout design in order to avoid incorrect FPC insertion.
 -Please keep enough FPC length and component layout space for assembly during design process.
 -FPC with too short length may make the assembly difficult.
 -Keep enough space for the rotation of the actuator during PCB and component layout design.
 -Please consult with our sales representative if you are using FPC with different configuration from our recommendation.

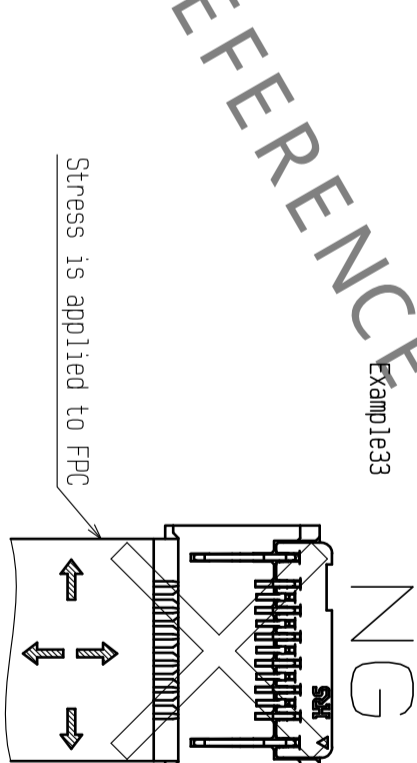

Example33

NG

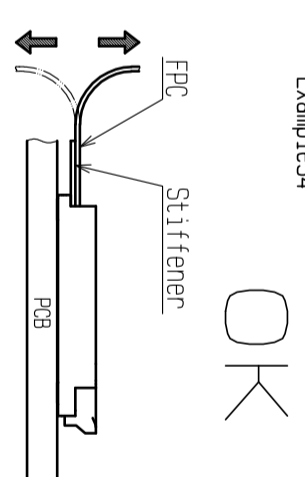

Example34

OK

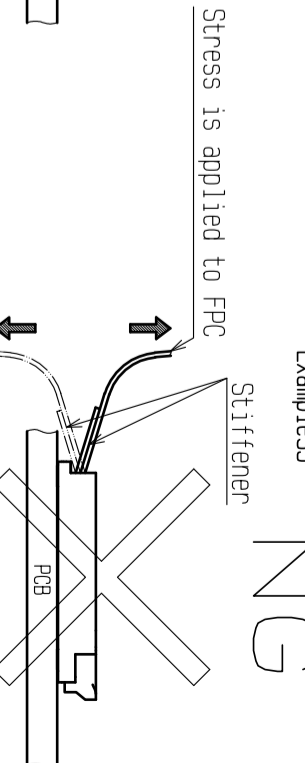

Example35

NG

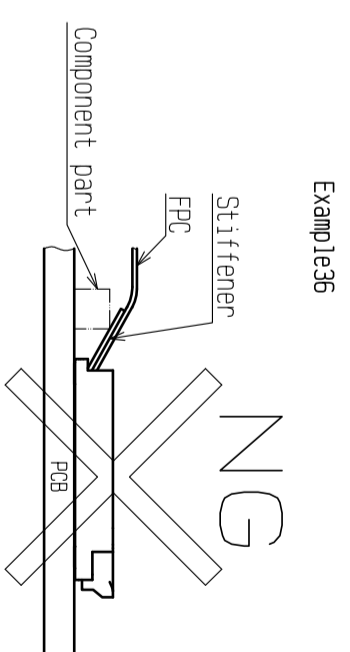

Example36

NG

<< INSTRUCTION MANUAL (4) >>

HRS	DRAWING NO.	EDC-375451-00-00
	PART NO.	FH64MA-**-S-0.25SHW
	CODE	CL580-
	NO.	

Instructions for mounting on the PCB

Follow the instructions shown below when mounting on the PCB.

- [Caution]
- Refer to recommended layouts on page 1 for PCB and stencil pattern.
 - Using either narrower land pattern or wider stencil pattern than recommendation may end up with excessive amount of solder/flux climbing on contact.
 - Please inspect the size of solder fillet and flux climbing height of the mounted connector while using different land/stencil pattern from our recommendation.
 - Clearance between the mounting surface of the connector contact lead and the bottom of the housing is very small. Solder resist/silk screening applied underneath the connector may interfere with the connector. This may lead to soldering defect/insufficient fillet formation.
 - Please verify your solder resist/silk screening design carefully before implementing the design.
 - Please try to minimize the warpage of the PCB. Soldering failure could still occur due to the PCB warpage even if the coplanarity of the connector is under 0.1mm.
 - If the connector is mounting on FPC, please make sure to put a stiffener on the backside of the FPC.
 - Recommended stiffener: Glass epoxy material with thickness of 0.3 mm MIN.
 - Do not apply 0.5 N or greater external force on the connector when unreeing or handling the connector before mounting.
 - Excessive mechanical stress may damage the connector before mounting.
 - Apply reflow temperature profile within the specified conditions.
 - For specific applications, the recommended temperature may vary depending on type/volume/thickness of solder paste and size/thickness of PCB.
 - Please consult with your solder paste and equipment manufacturer for specific recommendations.
 - The temperatures mentioned below refer to the PCB surface temperature near the connector contact leads.
 - Reflow method: IR reflow
 - Number of reflow cycles: 2 cycles MAX.

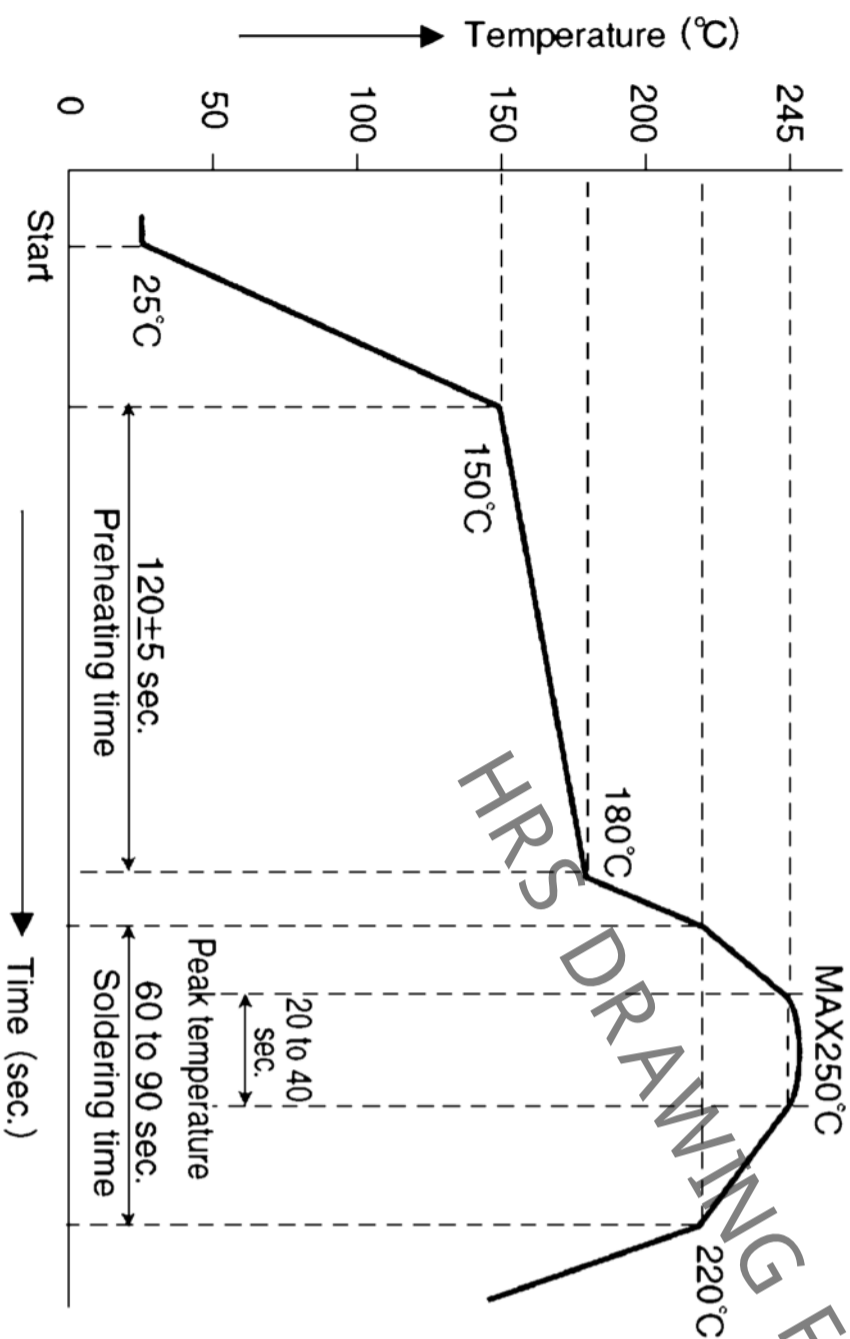

Instructions for PCB handling after mounting the connector

Follow the instructions shown below when mounting on the PCB.

- [Caution]
- Spitting a large PCB into several pieces
 - Installing mounting screw on PCB
- During the assembly processes described above, care shall be taken so as not to give any stresses of deflection or twisting to the PCB. Stresses applied on PCB may damage the connector as well.
- The warpage of a 100 mm wide PCB should remain within 0.5 mm. (Example 37)
- The warpage of PCB may apply excessive stress on the connector and damage the connector.

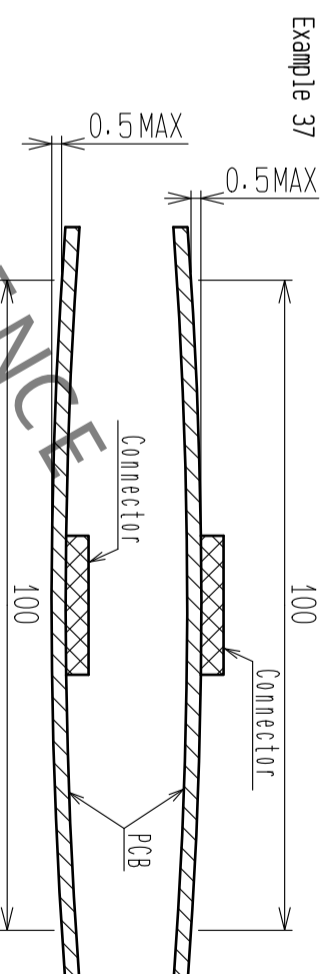

Instructions on manual soldering

Follow the instructions shown below when soldering the connector manually during repair work, etc.

- [Caution]
- Do not perform manual soldering with the FPC inserted into the connector.
 - Do not heat the connector excessively. Be very careful not to let the soldering iron contact any parts other than connector leads. Otherwise, the connector may be deformed or melt.
 - Do not supply excessive solder (or flux).
 - If excessive solder (or flux) is supplied on the contact lead, solder or flux may adhere to the contact point or rotating parts of the actuator, resulting in conduction failure or a rotation failure of the actuator.
 - Supplying excessive solder to the chucking metals may hinder actuator rotation, resulting in breakage of the connector.

[Others]

- Attachment of foreign particles with the connector contact may lead to conduction failure. (Example 38)
- In this particular case, the conduction failure may be fixed by re-inserting the FPC.
- Please perform conduction check with caution. Conductivity probe may damage the connector contacts.

Example 38)

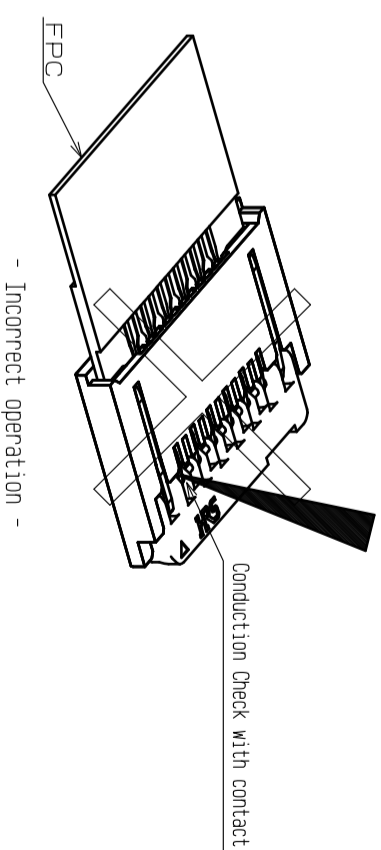

< INSTRUCTION MANUAL (5) >

HR5	
DRAWING NO.	EDC-375451-00-00
PART NO.	FH64MA-**-S-0.25SHW
CODE NO.	CL580-
	6/9