

MATERIALS AND FINISHES

BODY: BRASS  
PLATED TRI-M

CONTACT: BRASS  
PLATED SILVER

INSULATOR: TEFLON

COUPLING NUT: BRASS  
PLATED NICKEL

O-RING: SILICONE RUBBER

PERFORMANCE REQUIREMENTS:

FREQUENCY RANGE: 0-3800MHZ  
IMPEDANCE: 50 OHM  
WITHSTAND VOLTAGE(AC): 1500V @0.5mA  
VSWR: TYPE X TYPE Y  
≤1.05(0-1GHz) ≤1.10(820-970MHz)  
≤1.06(1-2.2GHz) ≤1.10(1700-2200MHz)  
≤1.10(2.2-3Hz) ≤1.10(2500-3800MHz)  
PIM3(2x20W): ≤-158dBc@1800MHz  
WATER-PROOF: IP68 WHEN MATED

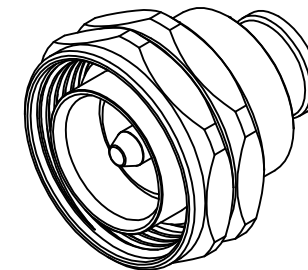

SEE TABLE:  
CONNECTORS SHIPPED  
WITH POLYETHYLENE DUST  
CAPS ON INTERFACE

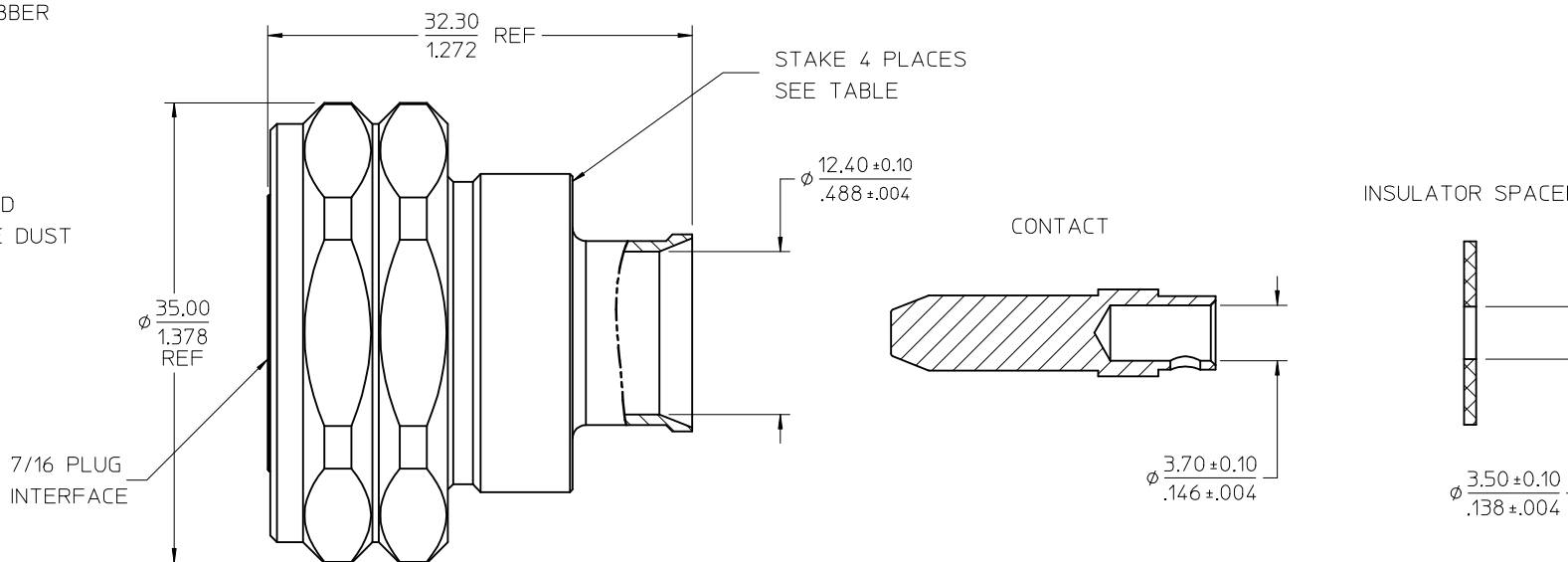

73134-0864	YES	YES	ONE PIECE PER CARTON
73134-0863	YES	NO	BLANK
73134-0862	YES	YES	ACOME BOX
73134-0861	NO	NO	NATURAL BOX
73134-0860	NO	NO	BLANK
PART NO.	STAKE	DUST CAP	PACKAGING

IEC60169-4	INTERFACE
SPECIFICATION	DESCRIPTION

CHG: ADD NEW PN. 73134-0864	EC NO: URF2017-0052 DRWN:YHUANG11 2016/08/02 CHKD: APPR:MYE08 2016/08/18	QUALITY SYMBOLS ▽=0 ▽=0 ▽=0	GENERAL TOLERANCES (UNLESS SPECIFIED) mm INCH 4 PLACES ± --- ± --- 3 PLACES ± --- ± --- 2 PLACES ± --- ± --- 1 PLACE ± --- ± --- 0 PLACE ± ±	DIMENSION STYLE MM/IN	SCALE	DESIGN UNITS METRIC	THIRD ANGLE PROJECTION	TITLE	SHEET NO. 1 OF 2
								7/16 PLUG STR, SOLDERING FOR 1/2SF CABLE, 50 OHM 7/16-PS	
A6			ANGULAR ± 2 °	MATERIAL NO.	DOCUMENT NO.	SD-73134-086			
DRAFT WHERE APPLICABLE MUST REMAIN WITHIN DIMENSIONS			SIZE	THIS DRAWING CONTAINS INFORMATION THAT IS PROPRIETARY TO MOLEX INCORPORATED AND SHOULD NOT BE USED WITHOUT WRITTEN PERMISSION					

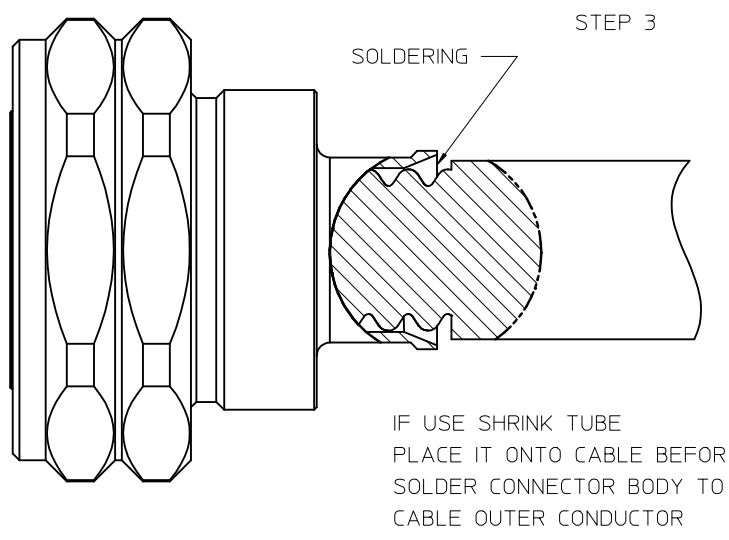
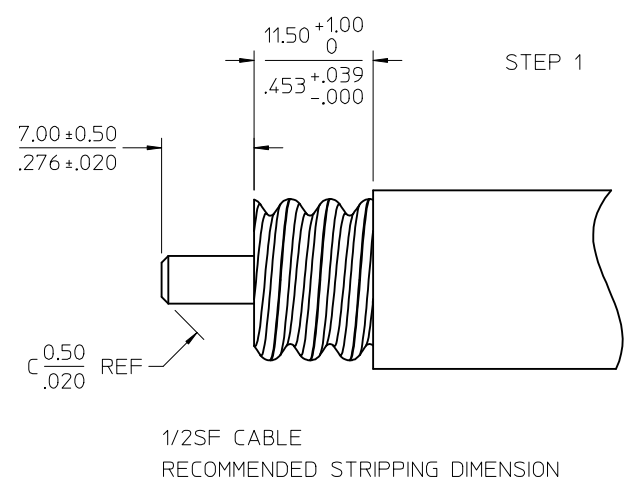
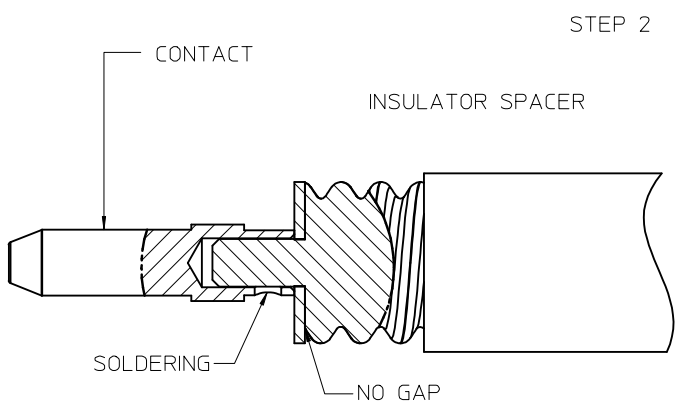

CHG: SEE SHEET 1	QUALITY SYMBOLS
EC NO: URF2017-0052	▽=0
DRWN:YHUANG11 2016/08/02	▽=0
CHKD: APPR:MYE08 2016/08/18	▽=0
REV: A6	DESCRIPTION

GENERAL TOLERANCES (UNLESS SPECIFIED)	
mm	INCH
4 PLACES ±	±
3 PLACES ±	±
2 PLACES ±	±
1 PLACE ±	±
0 PLACE ±	±
ANGULAR ± 2 °	
DRAFT WHERE APPLICABLE MUST REMAIN WITHIN DIMENSIONS	

DIMENSION STYLE	
MM/IN	
DRAWN BY	DATE
EWE1	2010/10/26
CHECKED BY	DATE
YHUANG11	2010/10/26
APPROVED BY	DATE
SRZHAO	2010/12/06
MATERIAL NO.	
SEE TABLE	

SCALE	DESIGN UNITS	THIRD ANGLE PROJECTION
	METRIC	
TITLE		SHEET NO.
7/16 PLUG STR, SOLDERING FOR 1/2SF CABLE, 50 OHM 7/16-PS		2 OF 2
DOCUMENT NO.		
SD-73134-086		
THIS DRAWING CONTAINS INFORMATION THAT IS PROPRIETARY TO MOLEX INCORPORATED AND SHOULD NOT BE USED WITHOUT WRITTEN PERMISSION		