

Spezifikation für Freigabe / specification for release

Kunde / customer :
 Artikelnummer / part number : **7499011122A**
 Bezeichnung : **LAN-Übertrager WE-RJ45LAN 10/100BaseT**
 description : **LAN-Transformer WE-RJ45LAN 10/100BaseT**



DATUM / DATE : 2014-10-28

A Mechanische Abmessungen / dimensions :

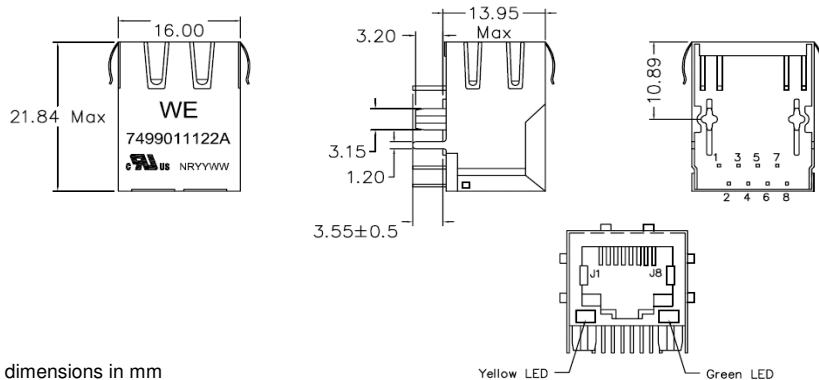

dimensions in mm

B Lötpad / soldering spec. :

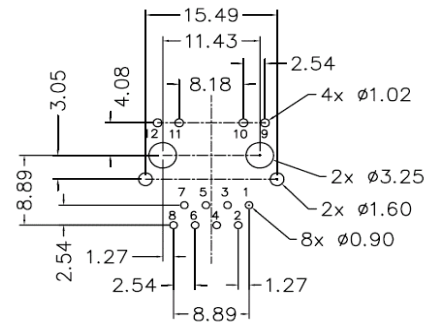

C Elektrische Eigenschaften / electrical properties :

| Eigenschaften / properties | Testbedingungen / test conditions | | Wert / value | Einheit / unit | tol. |
|--------------------------------------|-----------------------------------|-----|--------------|----------------|------|
| Induktivität / Inductance | 100kHz / 100mV @ 8mA DC-Bias | OCL | 350 | µH | min. |
| Übersetzungsverhältnis / Turns ratio | 100kHz / 100mV | TR | 1 : 1 | Tx | |
| | | | 1 : 1 | Rx | |
| Insertion Loss | 1-100MHz | IL | -1,0 | dB | max. |
| Return Loss | 1-30MHz | RL | -18 | dB | min. |
| | 30-45MHz | | -16 | | |
| | 45-60MHz | | -13,5 | | |
| | 60-80MHz | | -12 | | |
| Common Mode Rejection | 1-100MHz | CMR | -30 | dB | min. |
| Crosstalk | 1-100MHz | CT | -30 | dB | min. |

Suggested panel cutoff

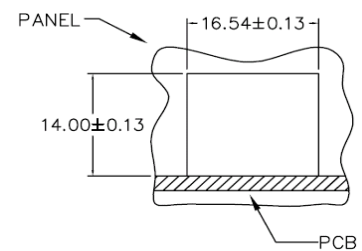

D Prüfgeräte / test equipment :

Agilent E5071C

E Testbedingungen / test conditions :

Luftfeuchtigkeit / humidity: 33%
 Umgebungstemperatur / temperature: +25°C

F Werkstoffe & Zulassungen / material & approvals :

Basismaterial / base material: Ferrit/ ferrite
 Draht / wire: 4UEW 180°C
 Kontaktmaterial/ contact plating: 100% tin w. nickel underplating
 30µ"gold plating on contact area
 Gehäuse / housing: Thermoplastic UL-94V0
 LED: 1,8-2,8 V/ 20mA
 Shield: 50µ" nickel
 over 0.01" cooper alloy

G Eigenschaften / general specifications :

Betriebstemp. / operating temperature: -40°C - +85°C
 Hochspannungsprüfung / Hipot test: 1500Vrms 1min.
 Geeignet für 10/100Base-TX gemäß IEEE 802.3u /
 Compliant with IEEE 802.3u for 10/100Base-TX-Applications
 Auto MDIX fähig / Auto MDIX capable

Freigabe erteilt / general release:

| Kunde / customer | | | |
|-------------------|--|--------------------------|-------------------------|
| Datum / date | | Unterschrift / signature | |
| | | Würth Elektronik | |
| Geprüft / checked | | Kontrolliert / approved | |
| | | Jliu | Rev 01 |
| | | Jliu | Rev 00 |
| | | | 2015-04-01 |
| | | | 2014-10-28 |
| | | Name | Änderung / modification |
| | | | Datum / date |

Würth Elektronik eiSos GmbH & Co.KG

D-74638 Waldenburg · Max-Eyth-Straße 1 · 3 · Germany · Telefon (+49) (0) 7942 - 945 - 0 · Telefax (+49) (0) 7942 - 945 - 400
<http://www.we-online.com>

Spezifikation für Freigabe / specification for release

Kunde / customer :
 Artikelnummer / part number : **7499011122A**
 Bezeichnung : **LAN-Übertrager WE-RJ45LAN 10/100BaseT**
 description : **LAN-Transformer WE-RJ45LAN 10/100BaseT**



DATUM / DATE : 2014-10-28

H Schaltbild / Schematics :

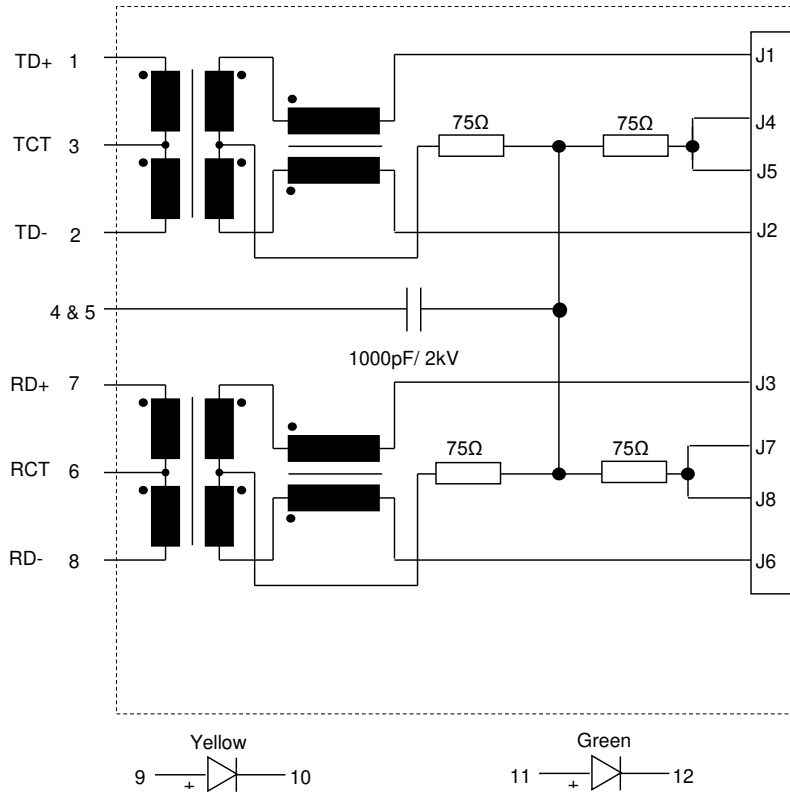

| | | | | |
|-------------------------------------|--------------------------|------|-------------------------|--------------|
| Freigabe erteilt / general release: | Kunde / customer | | | |
| | | | | |
| Datum / date | Unterschrift / signature | | | |
| | Würth Elektronik | | | |
| | | Jliu | Rev 01 | 2015-04-01 |
| Geprüft / checked | Kontrolliert / approved | Jliu | Rev 00 | 2014-10-28 |
| | | Name | Änderung / modification | Datum / date |

Würth Elektronik eiSos GmbH & Co.KG

D-74638 Waldenburg · Max-Eyth-Straße 1 - 3 · Germany · Telefon (+49) (0) 7942 - 945 - 0 · Telefax (+49) (0) 7942 - 945 - 400
<http://www.we-online.com>

Spezifikation für Freigabe / specification for release

Kunde / customer :
 Artikelnummer / part number : **7499011122A**
 Bezeichnung : **LAN-Übertrager WE-RJ45LAN 10/100BaseT**
 description : **LAN-Transformer WE-RJ45LAN 10/100BaseT**



DATUM / DATE : 2014-10-28

I Verpackungsspezifikation / package specification :

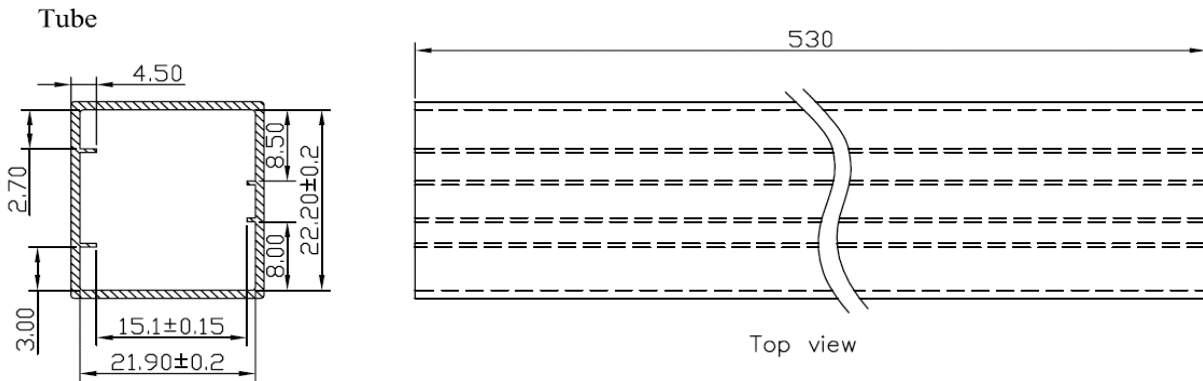

Carton

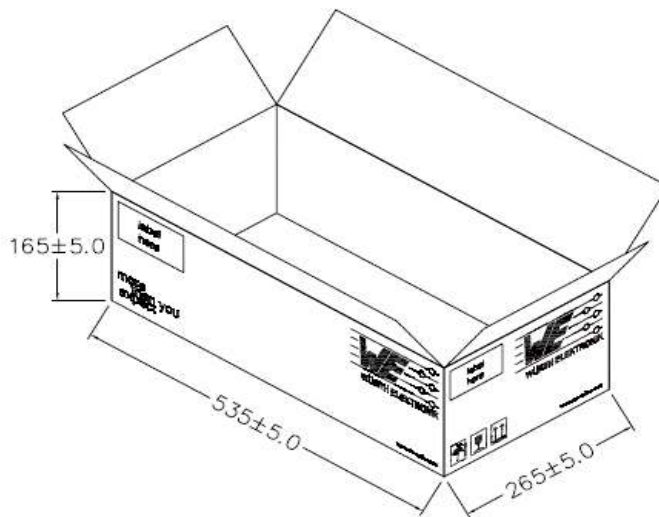

Package Quantity:

tube= 29pcs
 carton= 1740pcs

dimensions in mm

| | | | |
|-------------------------------------|--------------------------|------|-------------------------|
| Freigabe erteilt / general release: | Kunde / customer | | |
| | | | |
| Datum / date | Unterschrift / signature | | |
| | Würth Elektronik | | |
| | | | |
| Geprüft / checked | Kontrolliert / approved | Name | Änderung / modification |
| | | | Datum / date |
| | | Jliu | Rev 01 2015-04-01 |
| | | Jliu | Rev 00 2014-10-28 |

This electronic component has been designed and developed for usage in general electronic equipment. Before incorporating this component into any equipment where higher safety and reliability is especially required or if there is the possibility of direct damage or injury to human body, for example in the range of aerospace, aviation, nuclear control, submarine, transportation, (automotive control, train control, ship control), transportation signal, disaster prevention, medical, public information network etc. Würth Elektronik eiSos GmbH must be informed before the design-in stage. In addition, sufficient reliability evaluation checks for safety must be performed on every electronic component which is used in electrical circuits that require high safety and reliability functions or performance.

Würth Elektronik eiSos GmbH & Co.KG

D-74638 Waldenburg · Max-Eyth-Straße 1 · 3 · Germany · Telefon (+49) (0) 7942 - 945 - 0 · Telefax (+49) (0) 7942 - 945 - 400
<http://www.we-online.com>