

AFE1256 256-Channel, Analog Front-End for Digital X-Ray, Flat-Panel Detectors

1 Features

- 256 Channels
- On-Chip, 16-Bit ADC
- Photodiode Short Immunity
- Column Short Immunity
- High Performance:
 - Noise: 758 e-RMS with 28-pF Sensor Capacitor in 1.2-pC Range
 - Integral Nonlinearity: ± 2 LSB with Internal 16-Bit ADC
 - Minimum Scan Time:
 - 37.9 μ s in Normal Mode
 - 20 μ s in 2x Binning Mode
- Integration:
 - Eight Selectable Full-Scale Ranges: 0.15 pC (Min) to 9.6 pC (Max)
 - Built-In Correlated Double Sampler
 - 2x Binning (Averages Charge of Two Adjacent Channels) for Faster Throughput
 - Pipelined Integrate and Read: Allows Data Read During Integration
- Flexibility:
 - Electron and Hole Integration
- Low Power:
 - 2.9 mW/Ch with ADC
 - 2.3 mW/Ch without ADC
 - 0.1 mW/Ch in Nap Mode
 - Total Power-Down Feature
- 22-mm x 5-mm Gold-Bump Die, Suitable for TCP and COF

2 Application

Flat-Panel, X-Ray Detector

3 Description

The AFE1256 is a 256-channel, analog front-end (AFE) designed to suit the requirements of flat-panel detectors (FPDs) based on digital X-ray systems. The device includes 256 integrators, a programmable gain amplifier (PGA) for full-scale, charge-level selection, a correlated double sampler (CDS) with dual banking, 256:4 analog multiplexers, and four 16-bit, successive-approximation register (SAR) analog-to-digital converters (ADCs) onboard. Serial data from the ADCs are available in SPI™ format.

Hardware-selectable integration polarity allows for the integration of positive or negative charge and provides more flexibility in system design. The Nap feature enables substantial power saving. This power savings is especially useful in battery-powered systems.

The device is available as a 22-mm x 5-mm gold-bumped die and a 38-mm x 28-mm, COF-314 TDS package in singulated forms.

To request a full data sheet or other design resources: [request AFE1256](#)

Device Information⁽¹⁾

| ORDER NUMBER | PACKAGE | BODY SIZE |
|--------------|---------------------|---------------|
| AFE1256GBTD | Gold-bump die (533) | 22 mm x 5 mm |
| AFE1256TDS | COF (314) | 38 mm x 28 mm |

(1) For all available packages, see the package option addendum at the end of the data sheet.

(2) Product-preview device.

AFE1256 Schematic

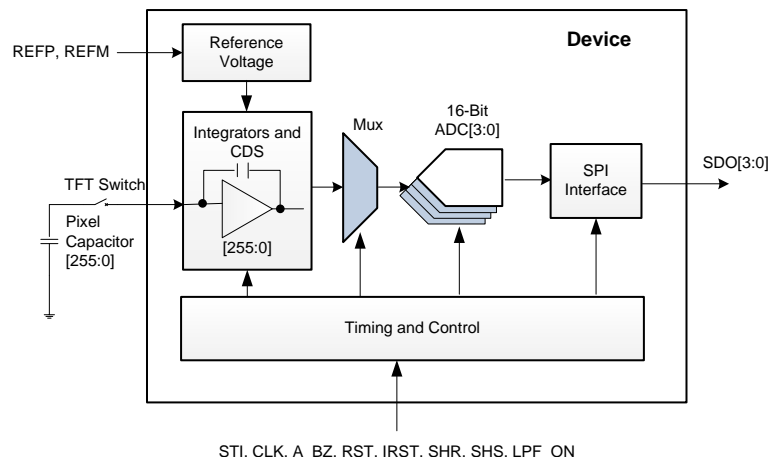

Table of Contents

| | |
|---|---|
| 1 Features 1 2 Application 1 3 Description 1 4 Revision History 2 5 Device and Documentation Support 3 5.1 Trademarks 3 | 5.2 Electrostatic Discharge Caution 3 5.3 Glossary 3 6 Mechanical, Packaging, and Orderable Information 3 6.1 Tray Dimensions 4 6.2 GBTD Die 5 |
|---|---|

4 Revision History

NOTE: Page numbers for previous revisions may differ from page numbers in the current version.

| Changes from Revision C (August 2015) to Revision D | Page |
|--|-------------|
| • Added link to request full data sheet | 1 |

| Changes from Revision B (April 2014) to Revision C | Page |
|--|-------------|
| • Changed document status from Mixed to Production Data | 1 |
| • Deleted TDQ package from document | 1 |
| • Changed last paragraph of <i>Description</i> section | 1 |
| • Deleted second row from <i>Device Information</i> table | 1 |
| • Changed <i>Tray Dimensions</i> section: deleted Figure 1 | 4 |

| Changes from Revision A (March 2014) to Revision B | Page |
|---|-------------|
| • Changed TDS package to Production Data | 1 |

| Changes from Original (October 2013) to Revision A | Page |
|---|-------------|
| • Made changes to product preview data sheet | 1 |

5 Device and Documentation Support

5.1 Trademarks

SPI is a trademark of Motorola.
All other trademarks are the property of their respective owners.

5.2 Electrostatic Discharge Caution



These devices have limited built-in ESD protection. The leads should be shorted together or the device placed in conductive foam during storage or handling to prevent electrostatic damage to the MOS gates.

5.3 Glossary

[SLYZ022](#) — *TI Glossary*.

This glossary lists and explains terms, acronyms, and definitions.

6 Mechanical, Packaging, and Orderable Information

The following pages include mechanical packaging and orderable information. This information is the most current data available for the designated devices. This data is subject to change without notice and revision of this document. For browser-based versions of this data sheet, refer to the left-hand navigation.

6.1 Tray Dimensions

Tray dimensions for the TDS package is shown in [Figure 1](#).

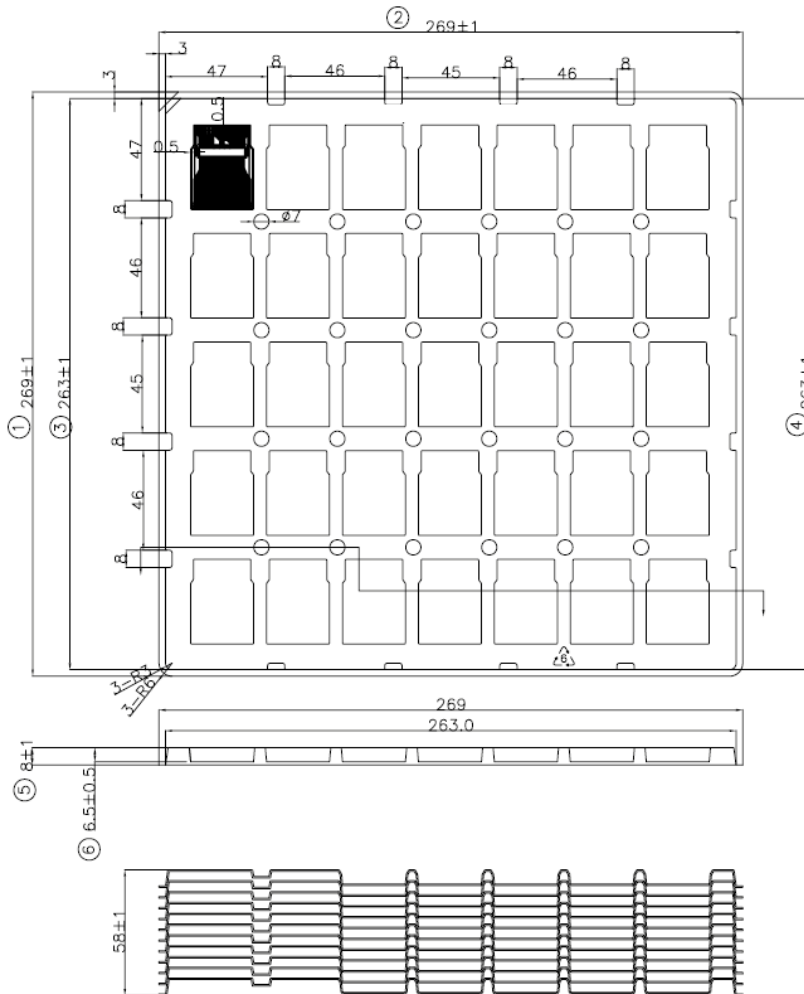

Remark : ^⑦
 1. Tray material : PS WHITE PREVENT
 PREVENT CONDUCT ELECTRICITY MATERIAL
 CONDUCT ELECTRICITY VALUE 10 ~10 Ω
 2. Material thickness: 0.70±0.2mm
 3. Singulation orientation: input side toward
 the up and SR towards the top(as drawing).

Figure 1. TDS Tray Dimensions

6.2 GBTD Die

Figure 2 does not take into account the scribe seal.

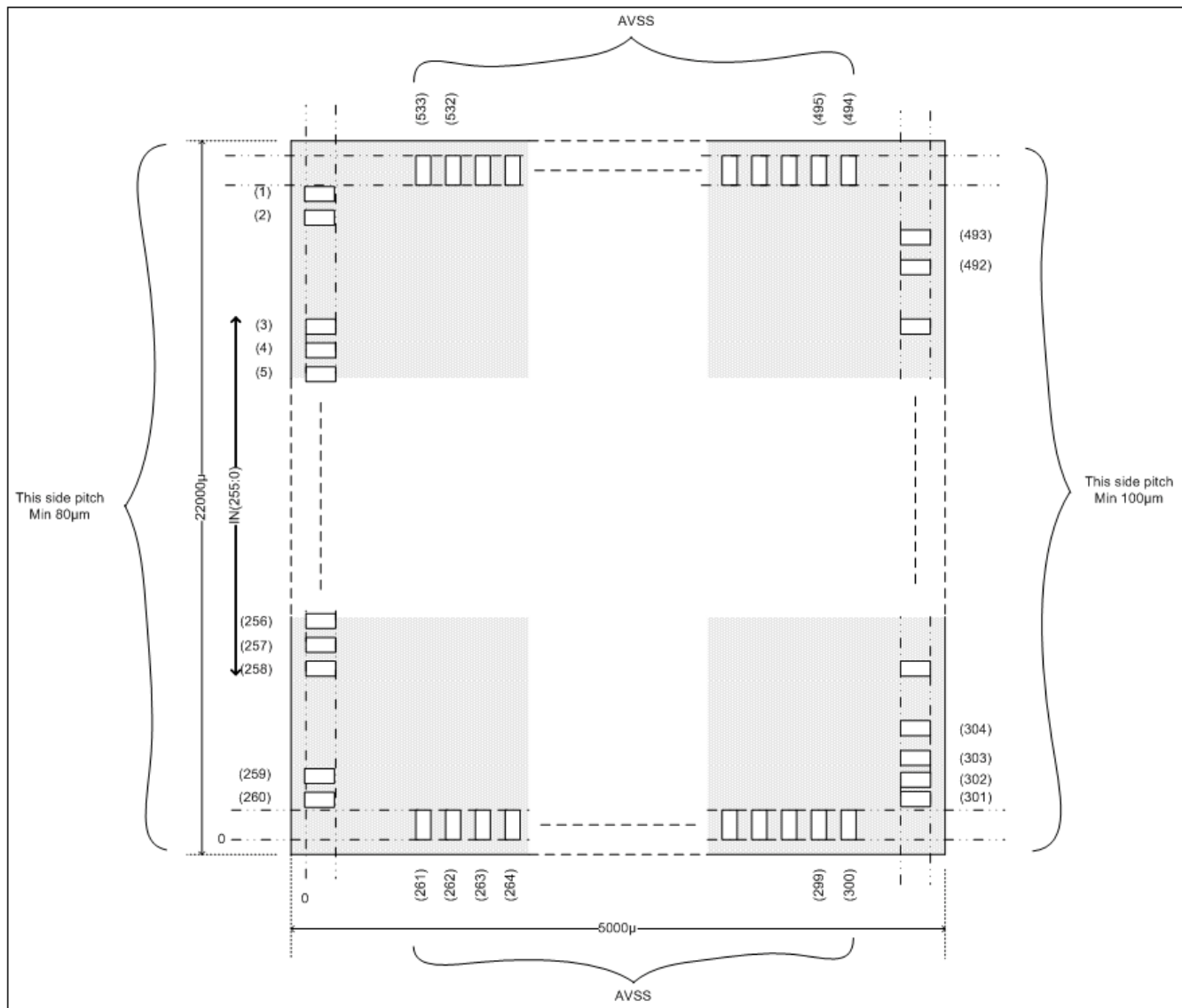

Figure 2. GBTD Die Mechanical Data

GBTD Die (continued)

Figure 3 provides the tray dimensions for the GBTD die.

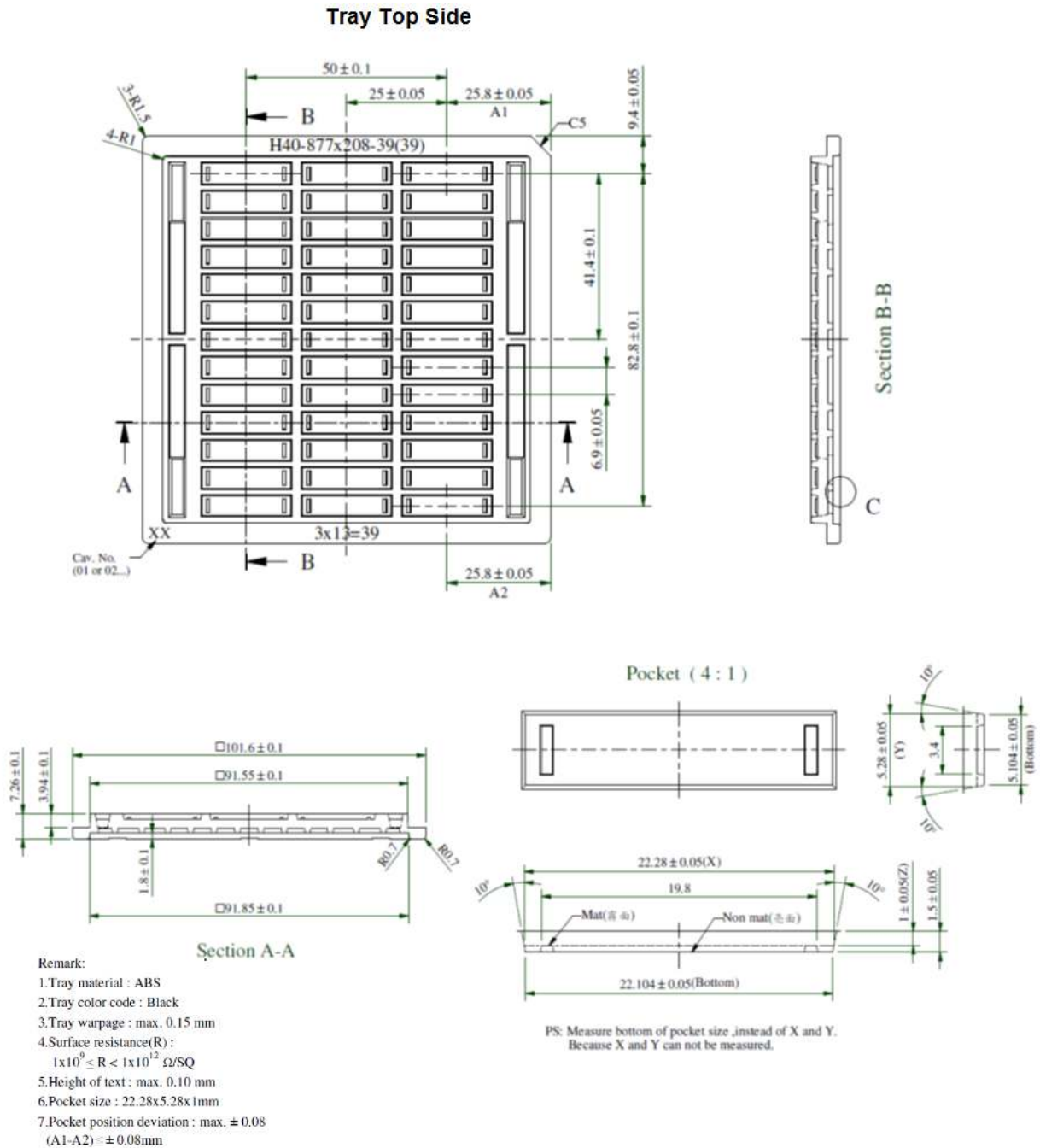

Figure 3. GBT Die Tray Dimension Details

GBTD Die (continued)

Dies are placed active side up (bumps up) into waffle pack. The waffle pack notch is at the upper right, as shown in Figure 4.

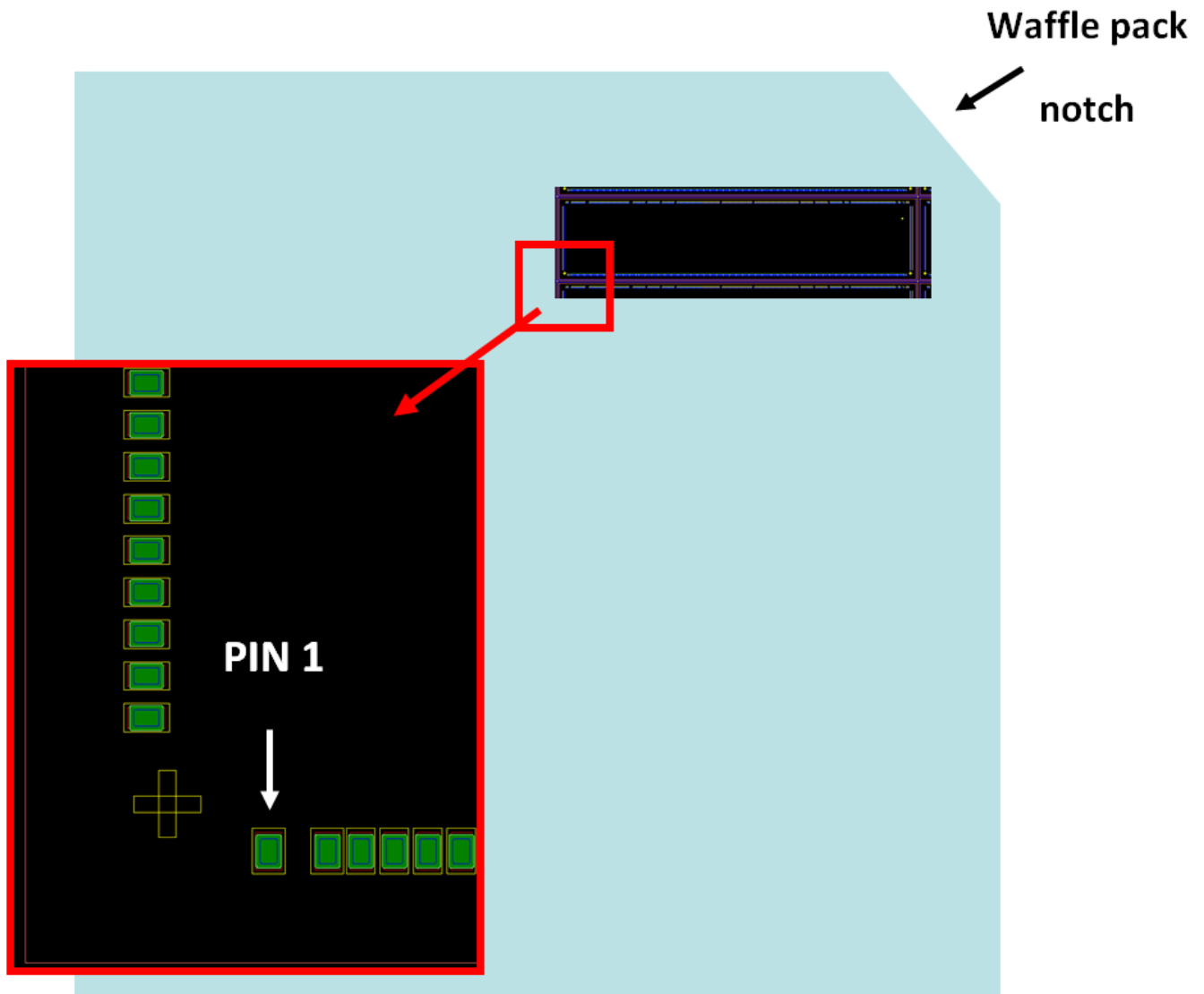

Figure 4. GBTD Die, Pin 1 Location

PACKAGING INFORMATION

| Orderable Device | Status (1) | Package Type | Package Drawing | Pins | Package Qty | Eco Plan (2) | Lead finish/ Ball material (6) | MSL Peak Temp (3) | Op Temp (°C) | Device Marking (4/5) | Samples |
|------------------|---------------|--------------|-----------------|------|-------------|-----------------|--------------------------------------|----------------------|--------------|-------------------------|-------------------------|
| AFE1256GBTD | ACTIVE | | | 0 | 39 | RoHS & Green | Call TI | Call TI | 0 to 70 | AFE1256 | Samples |
| AFE1256TDS | ACTIVE | COF | TDS | 314 | 35 | RoHS & Green | AU | N / A for Pkg Type | 0 to 70 | AFE1256TDS | Samples |

(1) The marketing status values are defined as follows:

ACTIVE: Product device recommended for new designs.

LIFEBUY: TI has announced that the device will be discontinued, and a lifetime-buy period is in effect.

NRND: Not recommended for new designs. Device is in production to support existing customers, but TI does not recommend using this part in a new design.

PREVIEW: Device has been announced but is not in production. Samples may or may not be available.

OBSOLETE: TI has discontinued the production of the device.

(2) **RoHS:** TI defines "RoHS" to mean semiconductor products that are compliant with the current EU RoHS requirements for all 10 RoHS substances, including the requirement that RoHS substance do not exceed 0.1% by weight in homogeneous materials. Where designed to be soldered at high temperatures, "RoHS" products are suitable for use in specified lead-free processes. TI may reference these types of products as "Pb-Free".

RoHS Exempt: TI defines "RoHS Exempt" to mean products that contain lead but are compliant with EU RoHS pursuant to a specific EU RoHS exemption.

Green: TI defines "Green" to mean the content of Chlorine (Cl) and Bromine (Br) based flame retardants meet JS709B low halogen requirements of <=1000ppm threshold. Antimony trioxide based flame retardants must also meet the <=1000ppm threshold requirement.

(3) MSL, Peak Temp. - The Moisture Sensitivity Level rating according to the JEDEC industry standard classifications, and peak solder temperature.

(4) There may be additional marking, which relates to the logo, the lot trace code information, or the environmental category on the device.

(5) Multiple Device Markings will be inside parentheses. Only one Device Marking contained in parentheses and separated by a "~" will appear on a device. If a line is indented then it is a continuation of the previous line and the two combined represent the entire Device Marking for that device.

(6) Lead finish/Ball material - Orderable Devices may have multiple material finish options. Finish options are separated by a vertical ruled line. Lead finish/Ball material values may wrap to two lines if the finish value exceeds the maximum column width.

Important Information and Disclaimer:The information provided on this page represents TI's knowledge and belief as of the date that it is provided. TI bases its knowledge and belief on information provided by third parties, and makes no representation or warranty as to the accuracy of such information. Efforts are underway to better integrate information from third parties. TI has taken and continues to take reasonable steps to provide representative and accurate information but may not have conducted destructive testing or chemical analysis on incoming materials and chemicals. TI and TI suppliers consider certain information to be proprietary, and thus CAS numbers and other limited information may not be available for release.

In no event shall TI's liability arising out of such information exceed the total purchase price of the TI part(s) at issue in this document sold by TI to Customer on an annual basis.

IMPORTANT NOTICE AND DISCLAIMER

TI PROVIDES TECHNICAL AND RELIABILITY DATA (INCLUDING DATA SHEETS), DESIGN RESOURCES (INCLUDING REFERENCE DESIGNS), APPLICATION OR OTHER DESIGN ADVICE, WEB TOOLS, SAFETY INFORMATION, AND OTHER RESOURCES "AS IS" AND WITH ALL FAULTS, AND DISCLAIMS ALL WARRANTIES, EXPRESS AND IMPLIED, INCLUDING WITHOUT LIMITATION ANY IMPLIED WARRANTIES OF MERCHANTABILITY, FITNESS FOR A PARTICULAR PURPOSE OR NON-INFRINGEMENT OF THIRD PARTY INTELLECTUAL PROPERTY RIGHTS.

These resources are intended for skilled developers designing with TI products. You are solely responsible for (1) selecting the appropriate TI products for your application, (2) designing, validating and testing your application, and (3) ensuring your application meets applicable standards, and any other safety, security, regulatory or other requirements.

These resources are subject to change without notice. TI grants you permission to use these resources only for development of an application that uses the TI products described in the resource. Other reproduction and display of these resources is prohibited. No license is granted to any other TI intellectual property right or to any third party intellectual property right. TI disclaims responsibility for, and you will fully indemnify TI and its representatives against, any claims, damages, costs, losses, and liabilities arising out of your use of these resources.

TI's products are provided subject to [TI's Terms of Sale](#) or other applicable terms available either on ti.com or provided in conjunction with such TI products. TI's provision of these resources does not expand or otherwise alter TI's applicable warranties or warranty disclaimers for TI products.

TI objects to and rejects any additional or different terms you may have proposed.

Mailing Address: Texas Instruments, Post Office Box 655303, Dallas, Texas 75265
Copyright © 2022, Texas Instruments Incorporated