

Atmel LED Driver-MSL2162

16-string White and RGB LED Driver with Adaptive Configuration, EEPROM, and SPI Bus

Datasheet Brief



Atmel LED Driver-MSL2162

16-string White and RGB LED Driver with Adaptive Configuration, EEPROM, and SPI Bus

General Description

The Atmel LED Driver-MSL2162 compact, high-power LED string driver uses external current control MOSFETs to sink up to 350mA per string, with current accuracy and matching better than 1.5%. The MSL2162 drives 16 parallel strings of LEDs, and offers fault detection and management of open and short circuit LEDs.

The MSL2162 features a 20 MHz SPI bus that supports video frame-by-frame LED string intensity control for up to eight interconnected devices. Frame-by-frame control allows active area dimming and phase shifted PWM timing for improved backlight performance. The advanced PWM engine synchronizes PWM dimming to the video signals for reduced motion blur and waterfall noise.

The MSL2162 adaptively controls the DC-DC converters powering the LED strings, using Atmel efficiency optimizers to minimize power use while maintaining LED current accuracy.

A unique combination of regulation current control and pulse width dimming management offers simple, full-screen brightness control, versatile area dimming, and a consistent white point. A current sense resistor sets LED current for each string, offering the flexibility to drive each string with a different current. 8-bit control adjusts LED current equally for all 16 LED strings. Separate 12-bit registers control individual string pulse width dimming.

The MSL2162 monitors LED strings for open circuit, short circuit, loss-of-video-sync, and over-temperature faults, and provides a hardware fault output to notify a microcontroller. Use the serial interface for detailed fault status and control. Additionally, the MSL2162 includes on-chip EEPROM that allows customization of the power-up defaults, accessible through the serial interface.

The MSL2162 is packaged in a 9 x 9 x 0.85mm, 64-lead TQFN, and operates over a -40°C to 105°C temperature range.

Applications

Long Life, Efficient LED Backlighting for:

- Televisions and Desktop Monitors
- Medical and Industrial Instrumentation
- Automotive Audio-visual Displays

Channel Signs

Architectural Lighting

Ordering Information

16-CHANNEL LED STRING DRIVERS		
PART	INTERFACE	PACKAGE
MSL2162DQ	SPI	64-pin, 9 x 9 x 0.85mm TQFN

Atmel LED Driver-MSL2162

16-string White and RGB LED Driver with Adaptive Configuration, EEPROM, and SPI Bus

Key Features

- 12-bit PWM String Dimming Control
- Fast 20MHz SPI Bus Supports up to Eight MSL2162s per SPI Bus Chip Select
- 8-bit Adaptive Power Correction Maximizes System Efficiency by Controlling up to Two Power Supply Voltages
- External Current Control MOSFETs for High Voltage and/or Current
- Drives up to 16 Parallel LED Strings per Device
- Supports Adaptive, Real-time Area Dimming for Highest Dynamic Range LCD TVs and Monitors
- Programmable String Phase Reduces Motion Blur and Improves Efficiency
- Global Intensity Control via Serial Interface
- $\pm 1.5\%$ Current Accuracy and Current Balance
- Flexible Video Frame (VSYNC) and Line (HSYNC) Sync Includes Frequency Multipliers and Dividers
- Second Set of PWM Registers Allows Alternate Brightness and Timing Selection with a Single Control
- EEPROM Saves Power-on Default Settings
- LED Open Circuit and Short Circuit Fault Detection
- Individual Per-String Fault Detection Enable
- Over-temperature Shut-off Protection
- Broadcast Write Simplifies Configuration
- -40°C To $+105^{\circ}\text{C}$ Operating Temperature Range

Application Circuit

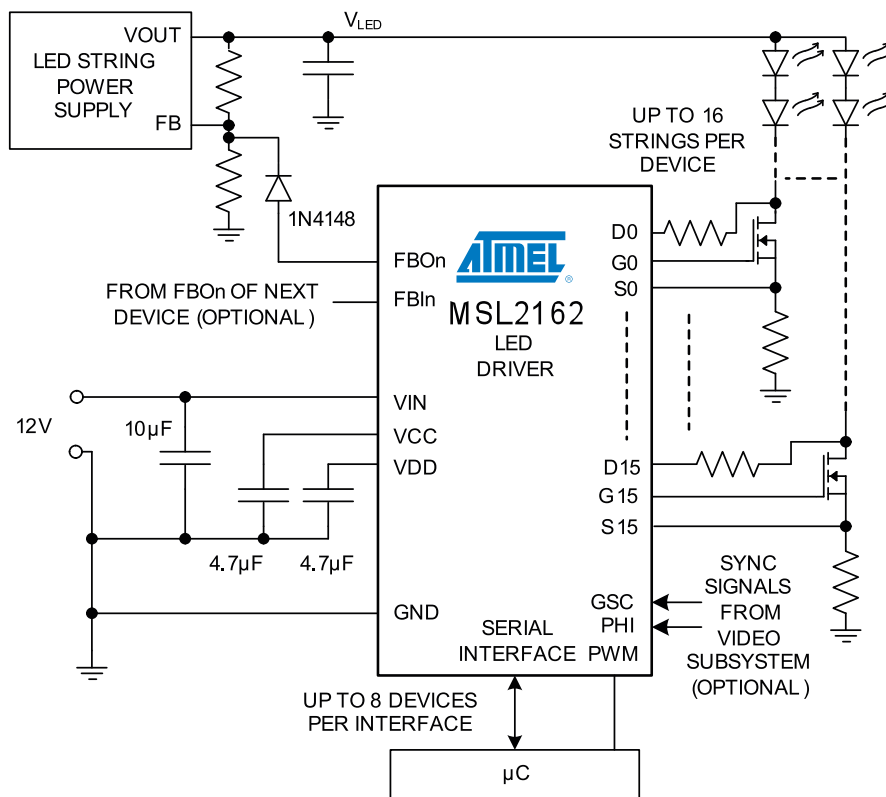



Quick Start Guide

The MSL2162 LED string controller drives, monitors, and dims multiple LEDs at high efficiency for LCD backlighting and signage applications. This section summarizes the capabilities of the MSL2162 for quick evaluation.

How Many LEDs and Drivers?

The MSL2162 controls 16 strings of series-connected LEDs at up to 350mA per string. Up to eight MSL2162s share a serial interface. The maximum number of LEDs per string is determined by the maximum power supply voltage, the LED forward voltage drop (V_f), and the gate drive outputs of the MSL2162. The MSL2162 FET gate drive outputs are optimized for FETs requiring up to 10nC of charge.

LED Power Supplies and Efficiency Optimizers (EOs)

The MSL2162 Efficiency Optimizer (EO) circuits dynamically adjust up to two LED string power supplies to the minimum voltage necessary to accurately drive the LED strings while assuring accurate current flow. The power supplies can use any topology, and are typically DC-DC boost or buck, or AC-DC off-line switcher supplies. The EOs rely on close matching of the LED strings connected to a string supply. The better the matching, the better is the overall efficiency. Multiple devices easily link together to optimize a single power supply.

Timing, PWM, Intensity Controls, and Synchronization

For video applications, the PWM LED drive signals synchronize to the LCD's video frame timing via the PHI input, and to the LCD's pixel timing via the GSC input. This synchronization eliminates beating artifacts. Suitability for LED backlight architectures is shown in Table 1. Area LED dimming for direct backlighting is supported for contrast and color gamut improvement. Motion blur is reduced by setting each LED string's PWM phasing individually to synchronize PWM off-times with the LCD update timing.

The MSL2162 also includes easily controlled internal PWM timing generation for standalone (non-video) LED lighting applications that do not provide external timing sources. One MSL2162 simply generates PWM timing for itself, and for the other devices in a multiple device application. Optionally, a single external PWM signal applied to the PWM input controls all of the strings on-times, with automatic progressive phase delay available through a single control bit.

Table 1. LED Common Backlight Drive Architectures and Features

BACKLIGHT TYPE	MOTION BLUR REMOVAL	AREA DIMMING MANAGEMENT	STRING SUPPLY OPTIONS
White LED - bottom edge-Lit	No	No	Up to two Efficiency Optimized power supplies
White LED - top/bottom edge-Lit	No	No	
White LED - 4 sides edge-lit	No	No	
White LED - direct back-lit	Yes, LED string phasing	Higher contrast ratio (area dimming)	Two Efficiency Optimized power supplies
RGB LED - direct back-lit	Yes, LED string phasing	Higher contrast ratio and color gamut	

Atmel LED Driver-MSL2162

16-string White and RGB LED Driver with Adaptive Configuration, EEPROM, and SPI Bus

Table 2. Timing and LED Intensity Control Capability

LED INTENSITY CONTROL	RESOLUTION
Global LED string current adjust	8-bit DAC reduces string current globally from maximum set external resistors
Global LED string PWM	8-bit global PWM control
Individual LED string PWM	12-bit PWM individual string control
Total LED string PWM control	12-bit LED String PWMs, computed from global and individual PWM settings

Package Pinout

Figure 1. Atmel LED Driver-MSL2162 Pinout, 64-pin TQFN

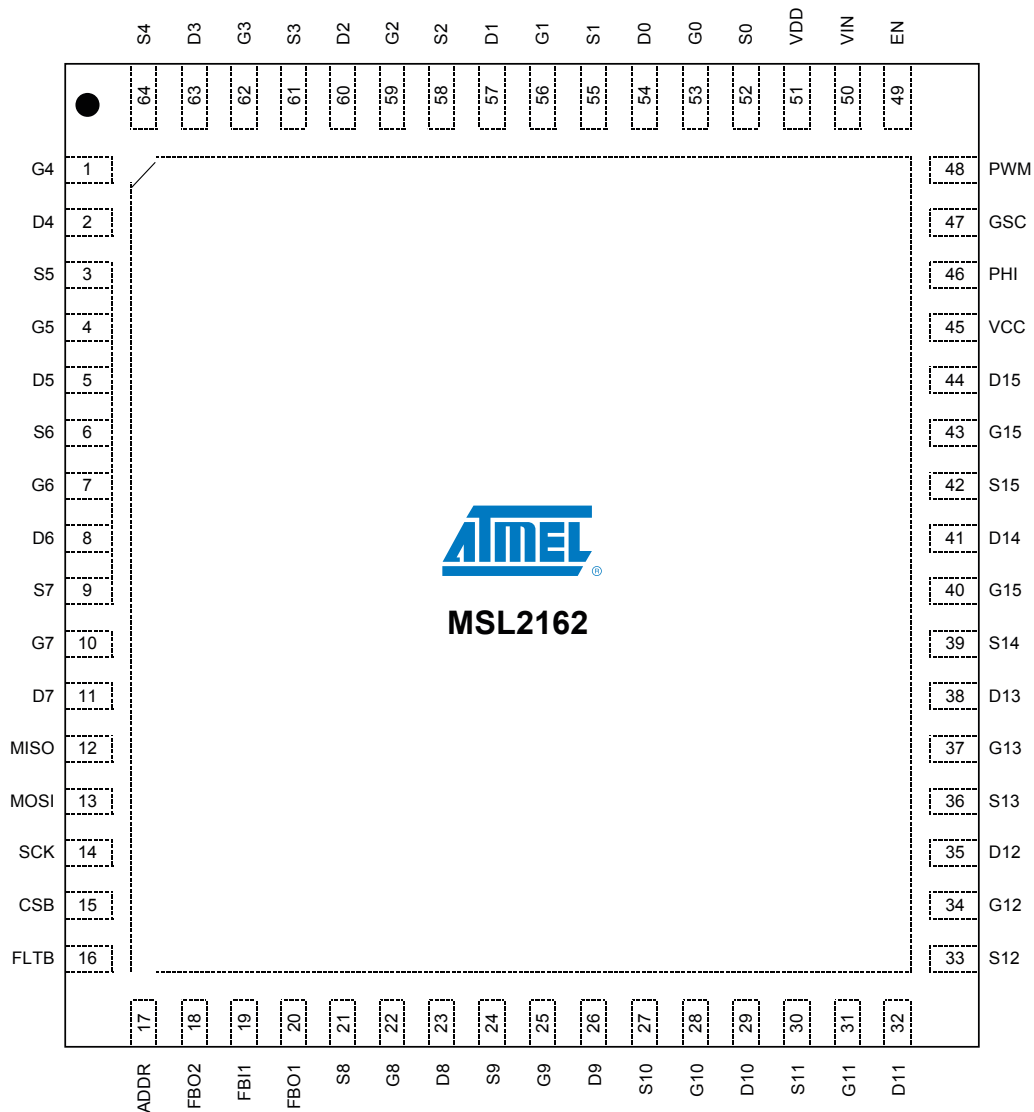
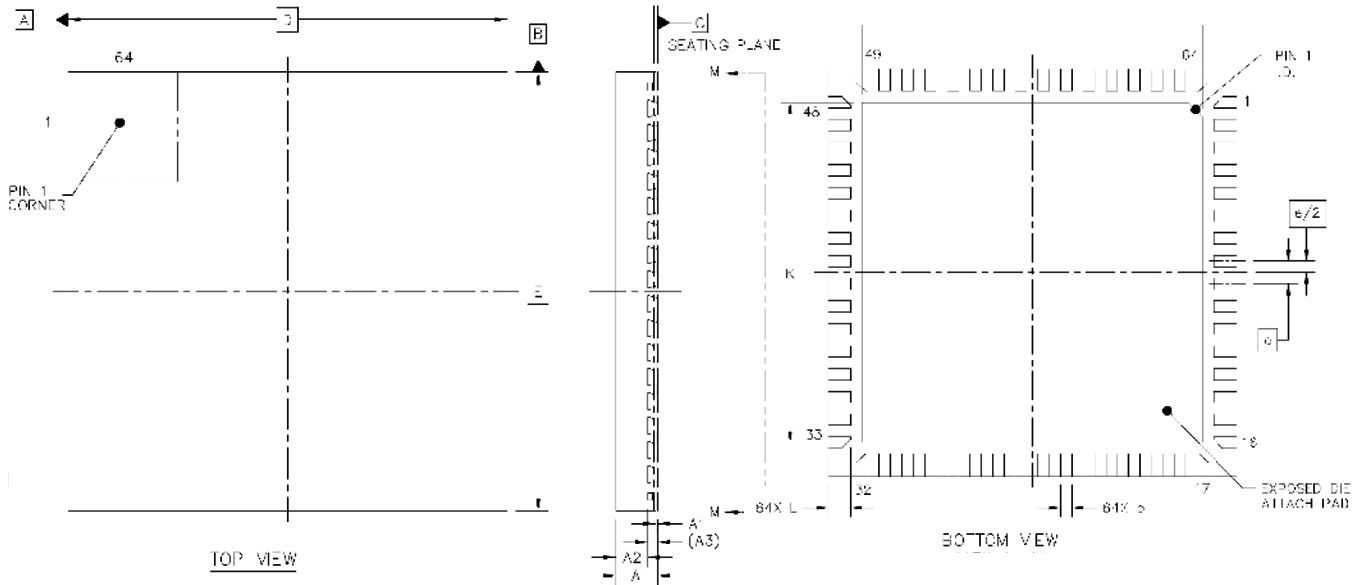

Figure 2. Package Dimensions: 64-lead, 9mm x 9mm x 0.85mm TQFN (0.5mm lead pitch) with Exposed Pad



		SYMBOL	MIN	NOM	MAX
TOTAL THICKNESS		A	0.8	0.85	0.9
STAND OFF		A1	0	0.035	0.05
MOLD THICKNESS		A2	---	0.65	0.67
L/F THICKNESS		A3	0.203 REF		
LEAD WIDTH		b	0.2	0.25	0.3
BODY SIZE	X	D	9 BSC		
	Y	E	9 BSC		
LEAD PITCH		e	0.5 BSC		
EP SIZE	X	J	7.4	7.5	7.6
	Y	K	7.4	7.5	7.6
LEAD LENGTH		L	0.45	0.5	0.55

Package Connection Description

Table 3. Atmel LED Driver-MSL2162 Connection Description

NO.	NAME	DESCRIPTION
1	G4	Gate output 4 Gate drive output for external MOSFET 4. Connect G4 to the gate of the external MOSFET driving LED string 4.
2	D4	Drain sense input 4 Drain sense input for external MOSFET 4. Connect D4 through a 10MΩ resistor to the drain of the external MOSFET driving LED string 4.

Atmel LED Driver-MSL2162

16-string White and RGB LED Driver with Adaptive Configuration, EEPROM, and SPI Bus

Table 3. Atmel LED Driver-MSL2162 Connection Description

NO.	NAME	DESCRIPTION
3	S5	Current sense input 5 Current sense input for LED string 5. Connect S5 to the source of the external MOSFET and to the current sense resistor for LED string 5. The full-scale LED current threshold is 500mV is across the current sense resistor.
4	G5	Gate output 5 Gate drive output for external MOSFET 5. Connect G5 to the gate of the external MOSFET driving LED string 5.
5	D5	Drain sense input 5 Drain sense input for external MOSFET 5. Connect D5 through a 10MΩ resistor to the drain of the external MOSFET driving LED string 5.
6	S6	Current sense input 6 Current sense input for LED string 6. Connect S6 to the source of the external MOSFET and to the current sense resistor for LED string 6. The full-scale LED current threshold is 500mV is across the current sense resistor.
7	G6	Gate output 6 Gate drive output for external MOSFET 6. Connect G6 to the gate of the external MOSFET driving LED string 6.
8	D6	Drain sense input 6 Drain sense input for external MOSFET 6. Connect D6 through a 10MΩ resistor to the drain of the external MOSFET driving LED string 6.
9	S7	Current sense input 7 Current sense input for LED string 7. Connect S7 to the source of the external MOSFET and to the current sense resistor for LED string 7. The full-scale LED current threshold is 500mV is across the current sense resistor.
10	G7	Gate output 7 Gate drive output for external MOSFET 7. Connect G7 to the gate of the external MOSFET driving LED string 7.
11	D7	Drain sense input 7 Drain sense input for external MOSFET 7. Connect D7 through a 10MΩ resistor to the drain of the external MOSFET driving LED string 7.
12	MISO	Master input, slave output MISO is the MSL2162 SPI bus data output.
13	MOSI	Master output, slave input MOSI is the MSL2162 SPI bus data input.
14	SCK	SPI serial shift clock SCK is the MSL2162 clock input for the SPI bus.



NO.	NAME	DESCRIPTION
15	CSB	Chip select bar CSB is the MSL2162 SPI bus chip select input for SPI transactions. Drive CSB low to enable serial interface communication.
16	FLT B	Fault indication output (active low) Open drain output FLT B sinks current to ground whenever the MSL2162 detects and verifies a fault. FLT B remains low until the fault registers are read, and reasserts if the fault persists.
17	ADDR	Slave ID selection inputs Connect ADDR to ground through a resistor to set the SPI bus address.
18	FBO2	Efficiency Optimizer output 2 Connect FBO2 to the second power supply's feedback node. Connect FBO2 to ground if unused.
19	FBI1	Efficiency Optimizer input 1 Connect FBI1 to FBO1 of the next device when connecting MSL2162s in series. If unused connect FBI1 to ground.
20	FBO1	Efficiency Optimizer output 1 Connect FBO1 to the first power supply's feedback node. Connect FBO1 to ground if unused.
21	S8	Current sense input 8 Current sense input for LED string 8. Connect S8 to the source of the external MOSFET and to the current sense resistor for LED string 8. The full-scale LED current threshold is 500mV is across the current sense resistor.
22	G8	Gate output 8 Gate drive output for external MOSFET 8. Connect G8 to the gate of the external MOSFET driving LED string 8.
23	D8	Drain sense input 8 Drain sense input for external MOSFET 8. Connect D8 through a 10M Ω resistor to the drain of the external MOSFET driving LED string 8.
24	S9	Current sense input 9 Current sense input for LED string 9. Connect S9 to the source of the external MOSFET and to the current sense resistor for LED string 9. The full-scale LED current threshold is 500mV is across the current sense resistor.
25	G9	Gate output 9 Gate drive output for external MOSFET 9. Connect G9 to the gate of the external MOSFET driving LED string 9.
26	D9	Drain sense input 9 Drain sense input for external MOSFET 9. Connect D9 through a 10M Ω resistor to the drain of the external MOSFET driving LED string 9.

Atmel LED Driver-MSL2162

16-string White and RGB LED Driver with Adaptive Configuration, EEPROM, and SPI Bus

NO.	NAME	DESCRIPTION
27	S10	Current sense input 10 Current sense input for LED string 10. Connect S10 to the source of the external MOSFET and to the current sense resistor for LED string 10. The full-scale LED current threshold is 500mV is across the current sense resistor.
28	G10	Gate output 10 Gate drive output for external MOSFET 10. Connect G10 to the gate of the external MOSFET driving LED string 10.
29	D10	Drain sense input 10 Drain sense input for external MOSFET 10. Connect D10 through a 10MΩ resistor to the drain of the external MOSFET driving LED string 10.
30	S11	Current sense input 11 Current sense input for LED string 11. Connect S11 to the source of the external MOSFET and to the current sense resistor for LED string 11. The full-scale LED current threshold is 500mV is across the current sense resistor.
31	G11	Gate output 11 Gate drive output for external MOSFET 11. Connect G11 to the gate of the external MOSFET driving LED string 11.
32	D11	Drain sense input 11 Drain sense input for external MOSFET 11. Connect D11 through a 10MΩ resistor to the drain of the external MOSFET driving LED string 11.
33	S12	Current sense input 12 Current sense input for LED string 12. Connect S12 to the source of the external MOSFET and to the current sense resistor for LED string 12. The full-scale LED current threshold is 500mV is across the current sense resistor.
34	G12	Gate output 12 Gate drive output for external MOSFET 12. Connect G12 to the gate of the external MOSFET driving LED string 12.
35	D12	Drain sense input 12 Drain sense input for external MOSFET 12. Connect D12 through a 10MΩ resistor to the drain of the external MOSFET driving LED string 12.
36	S13	Current sense input 13 Current sense input for LED string 13. Connect S13 to the source of the external MOSFET and to the current sense resistor for LED string 13. The full-scale LED current threshold is 500mV is across the current sense resistor.
37	G13	Gate output 13 Gate drive output for External MOSFET 13. Connect G13 to the gate of the external MOSFET driving LED string 13.



NO.	NAME	DESCRIPTION
38	D13	Drain sense input 13 Drain sense input for external MOSFET 13. Connect D13 through a 10MΩ resistor to the drain of the external MOSFET driving LED string 13.
39	S14	Current sense input 14 Current sense input for LED string 14. Connect S14 to the source of the external MOSFET and to the current sense resistor for LED string 14. The full-scale LED current threshold is 500mV is across the current sense resistor.
40	G14	Gate output 14 Gate drive output for external MOSFET 14. Connect G14 to the gate of the external MOSFET driving LED string 14.
41	D14	Drain sense input 14 Drain sense input for external MOSFET 14. Connect D14 through a 10MΩ resistor to the drain of the external MOSFET driving LED string 14.
42	S15	Current sense input 15 Current sense input for LED string 15. Connect S15 to the source of the external MOSFET and to the current sense resistor for LED string 15. The full-scale LED current threshold is 500mV is across the current sense resistor.
43	G15	Gate output 15 Gate drive output for external MOSFET 15. Connect G15 to the gate of the external MOSFET driving LED string 15.
44	D15	Drain Sense Input 15 Drain sense input for external MOSFET 15. Connect D15 through a 10MΩ resistor to the drain of the external MOSFET driving LED string 15.
45	VCC	5V internal LDO regulator output VCC powers the FBO outputs. Bypass VCC to ground with a 4.7μF ceramic capacitor placed close to VCC.
46	PHI	Phase synchronization input Drive PHI with an external signal from 40Hz to 10kHz kHz to synchronize the MSL2162 clock. In TV applications drive PHI with the VSYNC signal.
47	GSC	Gate shift clock input Drive GSC with the gate shift clock of the video signal, from 0 to 10kHz MHz. In TV applications drive GSC with the HSYNC signal.
48	PWM	PWM input PWM allows external control of the brightness of all LED strings. Drive PWM with a pulse-width modulated signal with duty ratio ranging from 0% to 100% and frequency up to 5kHz. When not configured as an input, PWM is high impedance.

Atmel LED Driver-MSL2162

16-string White and RGB LED Driver with Adaptive Configuration, EEPROM, and SPI Bus

NO.	NAME	DESCRIPTION
49	EN	Enable input (active high) Drive EN high to turn on the MSL2162, drive EN low to turn off the MSL2162. For automatic start-up, connect EN to VIN. When EN is low, the entire device, including the serial interface, is turned off. Drive EN high to initiate a boot load of the EEPROM data into the control registers to set the startup conditions.
50	VIN	Supply voltage input Connect a 12V \pm 10% supply to VIN. Bypass VIN to ground with a 10 μ F ceramic capacitor placed close to VIN.
51	VDD	2.5V internal LDO regulator output VDD powers internal logic. Bypass VDD to ground with a 4.7 μ F ceramic capacitor placed close to VDD.
52	S0	Current sense input 0 Current sense input for LED string 0. Connect S0 to the source of the external MOSFET and to the current sense resistor for LED string 0. The full-scale LED current threshold is 500mV is across the current sense resistor.
53	G0	Gate output 0 Gate drive output for external MOSFET 0. Connect G0 to the gate of the external MOSFET driving LED string 0.
54	D0	Drain sense input 0 Drain sense input for external MOSFET 0. Connect D0 through a 10M Ω resistor to the drain of the external MOSFET driving LED string 0.
55	S1	Current sense input 1 Current sense input for LED string 1. Connect S1 to the source of the external MOSFET and to the current sense resistor for LED string 1. The full-scale LED current threshold is 500mV is across the current sense resistor.
56	G1	Gate output 1 Gate drive output for external MOSFET 1. Connect G1 to the gate of the external MOSFET driving LED string 1.
57	D1	Drain sense input 1 Drain sense input for external MOSFET 1. Connect D1 through a 10M Ω resistor to the drain of the external MOSFET driving LED string 1.
58	S2	Current sense input 2 Current sense input for LED string 2. Connect S2 to the source of the external MOSFET and to the current sense resistor for LED string 2. The full-scale LED current threshold is 500mV is across the current sense resistor.
59	G2	Gate output 2 Gate drive output for external MOSFET 2. Connect G2 to the gate of the external MOSFET driving LED string 2.
60	D2	Drain sense input 2 Drain sense input for external MOSFET 2. Connect D2 through a 10M Ω resistor to the drain of the external MOSFET driving LED string 2.



NO.	NAME	DESCRIPTION
61	S3	Current sense input 3 Current sense input for LED string 3. Connect S3 to the source of the external MOSFET and to the current sense resistor for LED string 3. The full-scale LED current threshold is 500mV is across the current sense resistor.
62	G3	Gate output 3 Gate drive output for external MOSFET 3. Connect G3 to the gate of the external MOSFET driving LED string 3.
63	D3	Drain sense input 3 Drain sense input for external MOSFET 3. Connect D3 through a 10MΩ resistor to the drain of the external MOSFET driving LED string 3.
64	S4	Current sense input 4 Current sense input for LED string 4. Connect S4 to the source of the external MOSFET and to the current sense resistor for LED string 4. The full-scale LED current threshold is 500mV is across the current sense resistor.
EP	EP	Exposed pad, power ground Connect EP to system ground using short, wide traces. EP is also the thermal relief pad for the device.

Absolute Maximum Ratings

Voltage (With Respect to ground)

VIN, EN, D0 - D15, G0 - G15	-0.3V to +16V
VDD, ADDR, S0 - S15	-0.3V to +2.75V
FBO1, FBO2, FBI1, FLTb, PHI, GSC, PWM.....	-0.3V to +5.5V
VCC	-0.3V to +6V
MISO, MOSI, CSB, SCK	-0.3V to +5.5V

Current (Into Pin)

VIN.....	50mA
FBO1, FBO2.....	+0μA to -800μA
G0 - G15.....	±100mA
All other pins.....	20mA

Continuous Power Dissipation

64-Pin 9mm x 9mm QFN (derate 38mW/°C above T _A = +70°C)	2100mW
Ambient Operating Temperature Range T _A = T _{MIN} to T _{MAX}	-40°C to +105°C
Junction Temperature	+125°C
Storage Temperature Range	-65°C to +125°C
Lead Soldering Temperature, 10s	+300°C

Atmel LED Driver-MSL2162

16-string White and RGB LED Driver with Adaptive Configuration, EEPROM, and SPI Bus

Electrical Characteristics

Typical Application Circuit, $V_{VIN} = 12V$, $T_A = T_{MIN}$ to T_{MAX} , unless otherwise noted. Typical values are at $V_{VIN} = 12V$, $T_A = +25^\circ C$

PARAMETER	SYMBOL	CONDITIONS AND NOTES	MIN	TYP	MAX	UNIT
DC ELECTRICAL CHARACTERISTICS						
VIN Operating Supply Voltage	VIN		10.8	12	13.2	V
VIN Operating Supply Current	I_{VIN}	Normal Operation, all LED strings driven		25	32.5	mA
VIN Shutdown Supply Current	I_{SLEEP}	SLEEP = 1, SDA, SCL, ADDR, PWM, PHI and GSC at ground or VDD		500		μA
VCC Regulation Voltage	VCC	$I_{VCC} = -1.0mA$	4.5	5.0	5.5	V
VDD Regulation Voltage	VDD	$I_{VDD} = -1.0mA$	2.4	2.5	2.6	V
EN Input High Voltage			1.4			V
EN Input Low Voltage					0.9	V
PWM, PHI, GSC, Input High Voltage	V_{IH}		0.7 x VDD			V
PWM, PHI, GSC, Input Low Voltage	V_{IL}				0.3 x VDD	V
PHI, GSC Output High Voltage	V_{OH}	$I_{SOURCE} = 5mA$	VDD – 0.4			
PHI, GSC, FLTB Output Low Voltage	V_{OL}	$I_{SINK} = 6mA$			0.4	V
FBO Feedback Output Current Range		Compliance voltage 3.5V minimum	0		360	μA
FBO Feedback Output Current Step Size				1.2		μA
FBI Feedback Input Current			0		365	μA
FBI Input Disable Threshold					TBD	mV
D0 - D15 Short Circuit Fault Detection Threshold				8		V
G0 - G15 Open Circuit Fault Detection Threshold				8		V



PARAMETER	SYMBOL	CONDITIONS AND NOTES	MIN	TYP	MAX	UNIT
G0 - G15 Gate Drive Charge		(Note 2)			10	μC
S0 - S15 Regulation Voltage			492	500	508	mV
S0 - S15 Voltage Matching		ISTR = 0x7F	-1.5		1.5	%
Thermal Shutdown Temperature				135		$^{\circ}\text{C}$

PARAMETER	SYMBOL	CONDITIONS AND NOTES	MIN	TYP	MAX	UNIT
SPI LOGIC LEVELS						
MOSI, SCK, CSB Input High Voltage			0.7 x VDD			V
MOSI, SCK, CSB Input Low Voltage					0.3 x VDD	V
MISO Output High Voltage	V_{OH}	$I_{SOURCE} = 5\text{mA}$	$V_{IN} - 0.4$			V
MISO Output Low Voltage	V_{OL}	$I_{SINK} = 6\text{mA}$			0.4	V

PARAMETER	SYMBOL	CONDITIONS AND NOTES	MIN	TYP	MAX	UNIT
AC ELECTRICAL CHARACTERISTICS						
OSC Frequency	f_{OSC}	$f_{OSC} = 20\text{MHz}, T_A = 25^{\circ}\text{C}$	19.4	20	20.6	MHz
PHI Frequency	f_{PHI}		0.04		10	kHz
GSC Frequency	f_{GSC}		0		10	MHz
PWM Frequency	f_{PWM}				5	kHz
PWM Duty Cycle			0		100	%
PHI Lock				4		PHI cycles

Atmel LED Driver-MSL2162

16-string White and RGB LED Driver with Adaptive Configuration, EEPROM, and SPI Bus

PARAMETER	SYMBOL	CONDITIONS AND NOTES	MIN	TYP	MAX	UNIT
SPI TIMING CHARACTERISTICS						
SCK Frequency					20	MHz
CSB Falling Edge to SCK Rising Edge set-up Time	$t_{\text{CSB:SCK(SU)}}$		100			ns
SCK Falling Edge to CSB Rising Edge set-up Time	$t_{\text{SCK:CSB(SU)}}$		50			ns
MOSI to Falling Edge of SCK set-up Time	$t_{\text{MOSI(SU)}}$		16			ns
SCK Falling Edge to MOSI set-up Time	$t_{\text{MOSI(HOLD)}}$		20			ns
MOSI, CSB, SCK Signal Rise Time	$t_{\text{R(SPI)}}$			5.0		ns
MOSI, CSB, SCK Signal Fall Time	$t_{\text{F(SPI)}}$			5.0		ns
CSB Falling Edge to MISO Data Valid	$t_{\text{CSB:MISO(DV)}}$				50	ns
CSB Rising Edge to MISO High Impedance	$t_{\text{CSB:MISO(HIZ)}}$				50	ns
SCK Rising Edge to MISO Data Valid	t_{VALID}	SCK capacitive load = 200pF		25	80	ns

Note 1. Subject to thermal dissipation characteristics of the device.

Note 2. Guaranteed by design, not production tested.

Typical Application Circuit

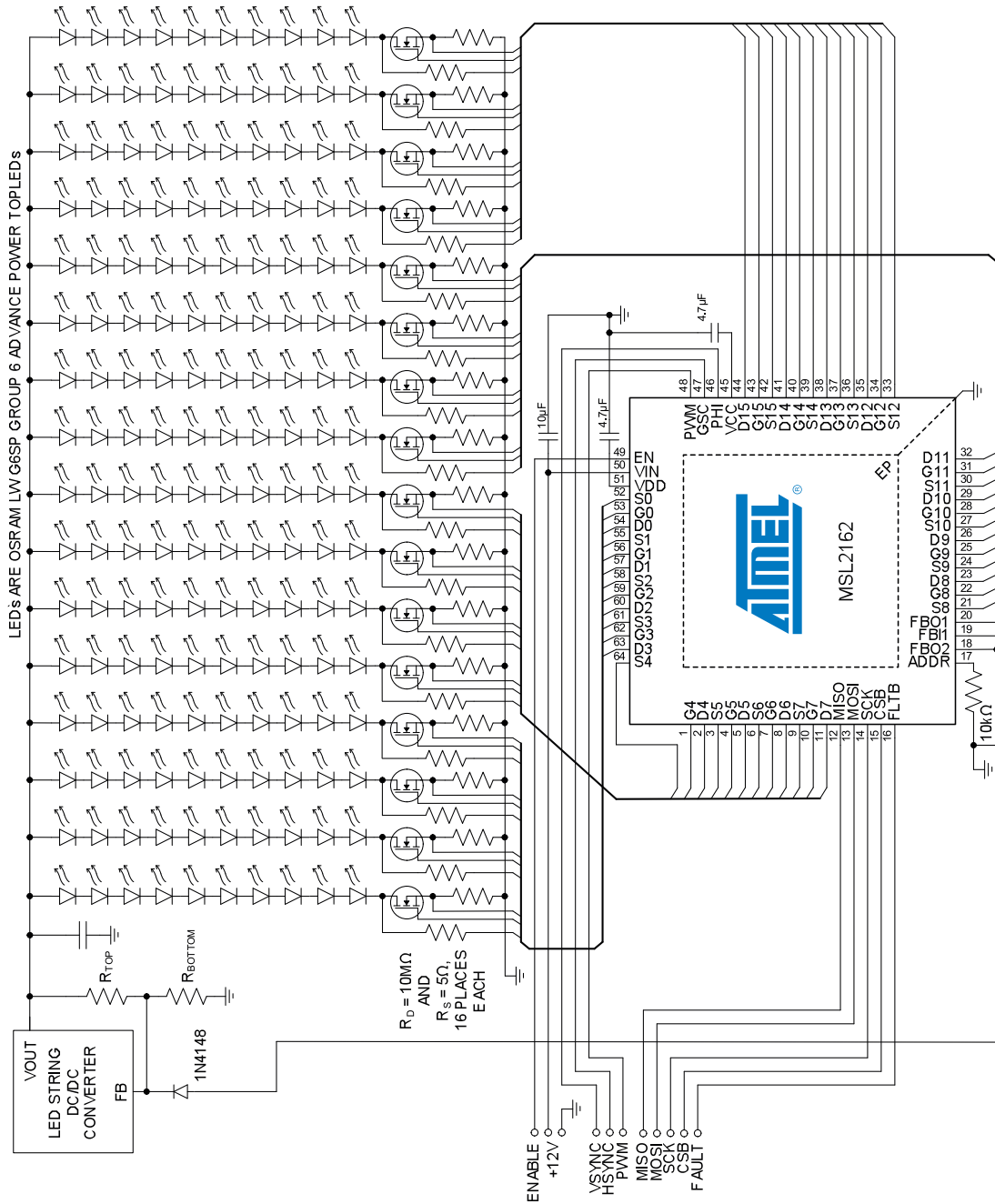

Figure 3. Atmel LED Driver-MSL2162 Driving 160 white LEDs in 16 Strings

Atmel LED Driver-MSL2162

16-string White and RGB LED Driver with Adaptive Configuration, EEPROM, and SPI Bus

Detailed Description

The MSL2162 is a highly integrated, flexible, multi-string LED driver. It drives external MOSFETs to allow high LED string currents, and includes power supply control to maximize efficiency. The driver optionally connects to a video subsystem to offer a simple architecture for use in LCD TV backlight applications. Up to eight devices easily connect together to drive large numbers of LED strings in a system. The driver provides multiple methods of controlling LED brightness, through both peak current control and through pulse width control of the string drive signals. Peak current control offers excellent color consistency, while pulse width control allows brightness management. An on-chip E²PROM holds all the default control register values. At power-up the data in the E²PROM automatically copy directly to the control registers, setting up the device for operation. The factory programmed E²PROM values are changed using the serial interface when a different power-up condition is desired.

The device interfaces to a microcontroller using an SPI compatible serial interface. The 20MHz SPI compatible interface supports up to eight devices per Chip Select line. While typically the LED drive PWM signal is internally generated, the driver also accepts an external direct PWM drive signal applied to the PWM input that sets the PWM duty and the frequency of the string drive signals. The MSL2162 also allows phase spreading when external PWM direct drive is used. With phase spreading enabled, a progressive 1/16 phase delay per string helps reduce both the transient load on the LED power supplies, and the power supply input capacitor size requirements.

The PWM frequency of the drivers is either synchronized to an external signal applied to PHI, or generated from the internal oscillator for stand-alone applications. Typically the VSYNC signal from the video system is used for the PHI input. A frequency multiplier (1x to 32x) processes this signal for use by the internal PWM engine. The on-time of each string is individually programmed via the device registers, providing a peak resolution of 12-bits when using the on-chip PWM generator. The actual resolution of the PWM frequency

depends upon on the ratio of the GSC frequency (typically provided by a systems HSYNC signal, but can be internally generated) to the PHI frequency, because the on-time of a string is programmed as a 12-bit count of the number of GSC clock cycles. This count can be further scaled by an 8-bit Global intensity value, when enabled. The GSC clock is also used to precisely set each string's phase delay so that it is synchronized to its physical position relative to the video frame.

The Efficiency Optimizers control a wide range of different architectures of external DC/DC and AC/DC converters. Multiple drivers in a system communicate with each other in real time to select an optimized operating voltage for the LEDs. This allows design of the power supply for the worst case Forward Voltage (V_f) of the LEDs without worrying about excessive power dissipation issues. During the start-up sequence the MSL2162 automatically reduces the power supply voltage to the minimum voltage required to keep the LEDs in current regulation. The devices can be configured to periodically perform this optimization to compensate for changes of the LED's forward voltage, and to assure continued optimum power savings.

Internal Regulators and Enable Input

The MSL2162 includes two internal linear regulators that provide VCC (5V) and VDD (2.5V) for internal circuitry. VIN (12V nominal) supplies the VCC and VDD regulators. Bypass VIN to ground with a 10 μ F capacitor close to the device. Bypass VCC to ground with a 4.7 μ F capacitor close to the device. Bypass VDD to ground with a 4.7 μ F capacitor close to the device.

The MSL2162 enable input, EN, enables the device. Drive EN low to enter low power operation, which lowers quiescent current draw to less than 20 μ A. With EN low the serial interface is ignored. Drive EN high to turn on the device. When EN is driven high the contents of the E²PROM are boot loaded into the control registers, simulating a cold start-up.



Setting the Maximum LED String Current with the Source Resistor

The maximum string current, I_{LEDn} , for each string is set by a shunt resistor connected to ground from the Source terminal of the string drive MOSFET. The feedback threshold is 500mV. Determine the resistor value using:

$$R_{Sn} = \frac{0.5}{I_{LEDn}} \Omega.$$

For example, a full-scale LED current of 100mA returns $R_{Sn} = 5\Omega$. The current for all LED strings is reduced from full-scale value with 8-bit resolution using ISTR, the String Current Control register 0x31.

Connecting the Efficiency Optimizer to an LED String Power Supply and Selecting Resistors

The MSL2162 is designed to control LED string power supplies that use a voltage divider (R_{TOP} and R_{BOTTOM} in Figure 4) to set output voltage, and whose regulation feedback voltage is not more than 3.5V.

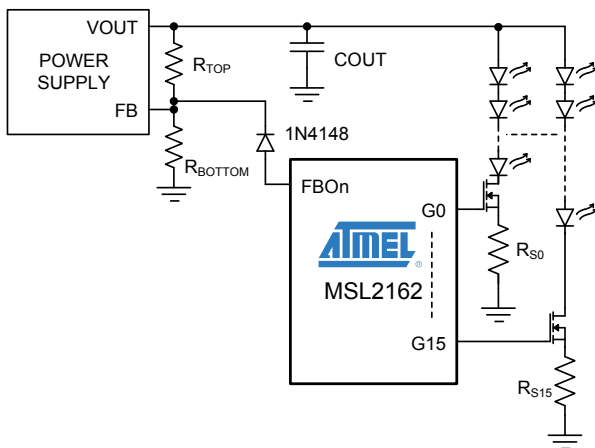

Figure 4. FBO_n Connects to the Power Supply Voltage Divider Through a Diode

To select the resistors first determine $V_{OUT(MIN)}$ and $V_{OUT(MAX)}$, the minimum and maximum string supply voltage limits, using:

$$V_{OUT(MIN)} = (V_{f(MIN)} * [\#ofLEDs]) + 0.5,$$

and

$$V_{OUT(MAX)} = (V_{f(MAX)} * [\#ofLEDs]) + 0.5,$$

where $V_{f(MIN)}$ and $V_{f(MAX)}$ are the LED's minimum and maximum forward voltage drops at the peak current set by R_{Sn} (page 10). For example, if the LED data are $V_{f(MIN)} = 3.5V$ and $V_{f(MAX)} = 3.8V$, and ten LEDs are used in a string, then the total minimum and maximum voltage drop across a string is 35V and 38V. Adding an allowance of 0.5V of for the string drive MOSFET headroom brings $V_{OUT(MIN)}$ to 35.5V and $V_{OUT(MAX)}$ to 38.5V. Then determine R_{TOP} using:

$$R_{TOP} = \frac{V_{OUT(MAX)} - V_{OUT(MIN)}}{I_{FBO_n(MAX)}},$$

where $I_{FBO_n(MAX)}$ is the 255 μ A maximum output current of the Efficiency Optimizer outputs FBO_n. Finally, determine R_{BOTTOM} using:

$$R_{BOTTOM} = R_{TOP} * \frac{V_{FB}}{V_{OUT(MAX)} - V_{FB}},$$

where V_{FB} is the regulation feedback voltage of the power supply. Place a diode (1N4148 or similar) between FBO and the supply's feedback node to protect the MSL2162 against current flow into FBO_n. Assign all strings powered by a common supply to the proper FBO output using String Set registers 0x40 - 0x5F; default assignments are presented in Table 5.

Once configured, determine the change in power supply output voltage in response to a change in FBO output current using:

$$\Delta V_{OUT} = \Delta I_{FBO} * R_{TOP}.$$

Atmel LED Driver-MSL2162

16-string White and RGB LED Driver with Adaptive Configuration, EEPROM, and SPI Bus

Using Multiple Atmel LED Driver-MSL2162s to Control a Common Power Supply

Multiple MSL2162s connect in a chain configuration to control a single string power supply (Figure 5) when driving more than 16 LED strings. Cascade multiple devices with the FBI1 of one device connected to the FBO1 of the next. Connect the first FBO1 to the power supply feedback resistor node through a diode, and the unused FBI1 input to ground as close to the MSL2162 as possible. Assume that all strings powered by the common supply are assigned to FBO1 using String Set registers (STRnSET) 0x40 - 0x5F (FBO1 is the power-up default setting for all strings). The chained devices work together to ensure that the system operates at optimum efficiency. Note that the accuracy of the feedback chain may degrade through each link of the FBI1/FBO1 chain by as much as 2%. Determine the potential worst case maximum FBO1 current $I_{FBO1(MAX/MIN)}$ using:

$$I_{FBO1(MAX/MIN)} = 255\mu A * (0.98)^{N-1},$$

where N is the number of MSL2162s connected in series. Use this result in the above R_{TOP} resistor equation for the term $I_{FBO1(MAX)}$ instead of using $255\mu A$.

Take care in laying out the traces for the Efficiency Optimizer connections. Minimize the FBI1/FBO1 trace lengths as much as possible. Do not route the signals close to traces with large variations in voltage or current, because noise may couple into FBI1. If these traces must be routed near noisy signals, shield them from noise by using ground planes or guard traces. Note that Figure 5 also shows the connections for an unused string.

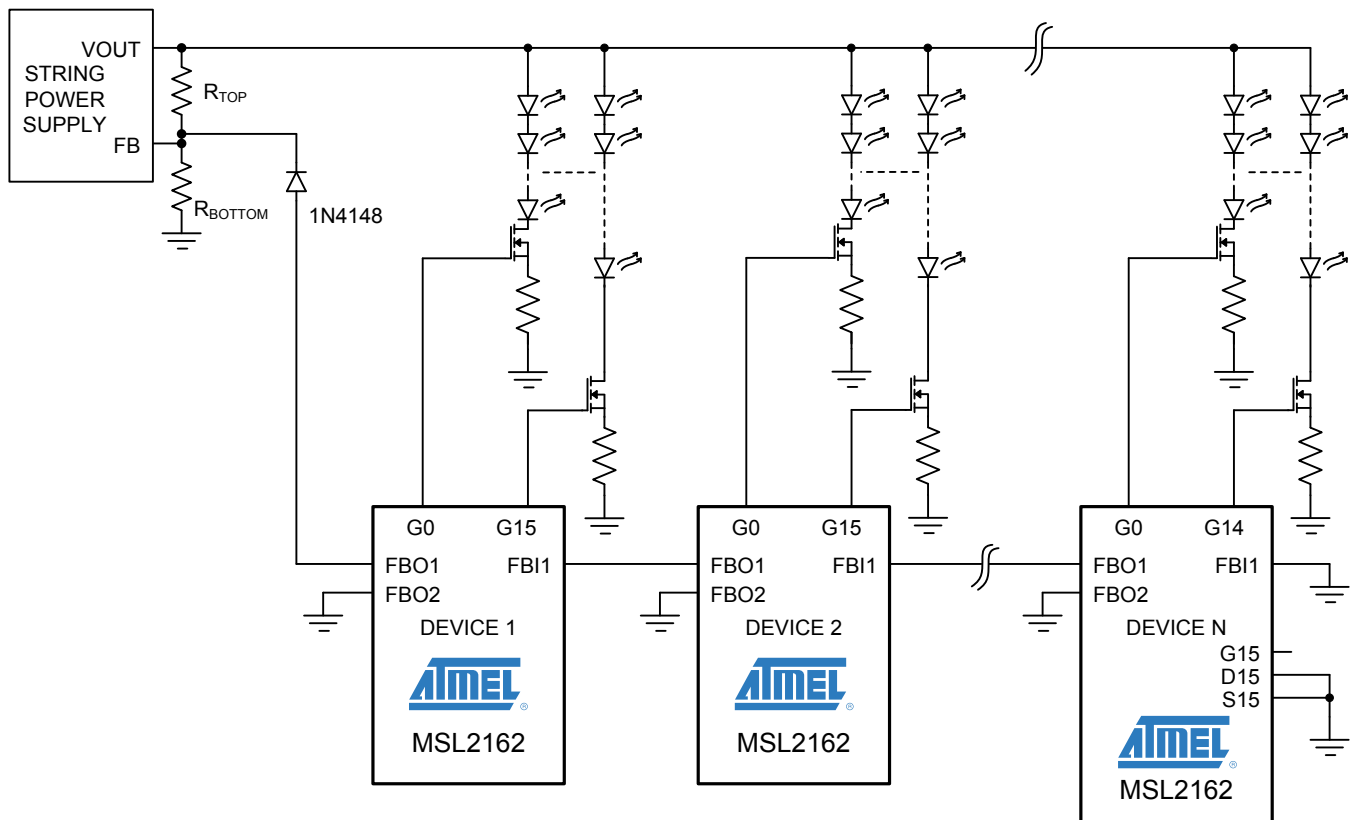

Figure 5. Example of Cascading Multiple Devices to Optimize a Common String Power Supply



Direct PWM Control of the LED Strings

An external PWM signal applied to the PWM input allows direct PWM control over the strings when bits PWMEN and PWMDIRECT (bits D0 and D1 in PWM Control register 0x2D) are set to 1. This configuration bypasses PHI and GSC, but allows LED string phase delay via the Phase Delay Enable bit PHADLYEN (bit D0 of register 0x2E). With phase delay enabled, a progressive delay of 1/16 the PWM frame is calculated and applied successively to each string drive signal.

Register Map and the E²PROM

Register Map Summary

Control the MSL2162 using the registers in the range 0x00 - 0xBF (Table 4). Two additional registers, 0xC0 and 0xC1, allow access to, and programming of, the E²PROM. The power-up default values for all control registers (Table 5) are stored within the on-chip E²PROM, and any of these E²PROM values may be changed through the serial interface

Table 4. Atmel LED Driver-MSL2162 Register Map

ADDRESS AND REGISTER NAME		FUNCTION	REGISTER DATA							
			D7	D6	D5	D4	D3	D2	D1	D0
0x00	STRINGEN0	LED string enables	STR7EN	STR6EN	STR5EN	STR4EN	STR3EN	STR2EN	STR1EN	STR0EN
0x01	STRINGEN1		STR15EN	STR14EN	STR13EN	STR12EN	STR11EN	STR10EN	STR9EN	STR8EN
0x02	CONFIG	Configuration	SLEEP	-	-	-	FLDBKEN	STRSCDLY[2:0]		
0x03	FLTEN	Fault enable	-	-	I ² CTOEN	PHIMAXFEN	GSCMAXFEN	STRSCFEN	STROCFEN	FBOOCFEN
0x04	STRFLTEN0	String fault enable	FEN7	FEN6	FEN5	FEN4	FEN3	FEN2	FEN1	FEN0
0x05	STRFLTEN1		FEN15	FEN14	FEN13	FEN12	FEN11	FEN10	FEN9	FEN8
0x06	FLTSTATUS	Fault status	FLTBDREV	-	-	PHIMAXFLT	GSCMAXFLT	STRSCFLT	STROCFLT	FBOOCFLT
0x07	OCSTAT0	String open circuit fault status	OC7	OC6	OC5	OC4	OC3	OC2	OC1	OC0
0x08	OCSTAT1		OC15	OC14	OC13	OC12	OC11	OC10	OC9	OC8
0x09	SCSTAT0	String short circuit fault status	SC7	SC6	SC5	SC4	SC3	SC2	SC1	SC0
0x0A	SCSTAT1		SC15	SC14	SC13	SC12	SC11	SC10	SC9	SC8
0x0B	THRU 0x0E	UNUSED								
0x0F	OSCFREQ	Oscillator frequency	-	-	-	-	-	OSCFREQ[2:0]		
0x10	FBOCTRL0	Efficiency Optimizer control	HLDSTEP[1:0]		FBCLDLY[1:0]		FBSDLY[1:0]		FBCFDLY[1:0]	
0x11	FBOCTRL1		INCRSTEP[1:0]		DECRSTEP[1:0]		INITPWM	ACAL100	ACALEN	TRIDIS
0x12	FBOCTRL2		-	-	-	-	-	FBO1OCEN	FBO0OCEN	FBOEN
0x13	FBODAC0	Efficiency optimizer DAC readback	FBODAC1[7:0]							
0x14	FBODAC1		FBODAC2[7:0]							
0x15	FBODAC2		FBODAC3[7:0]							
0x16	FBOSTAT	Efficiency optimizer status	-	FBO2OC	FBO1OC	-	FBO2ACT	FBO1ACT	FBOCAL	FBOINITCAL
0x17	THRU 0x1F	UNUSED								
0x20	GSCCTRL	GSC processing control	GSCCHKSEL	-	-	-	GSCMAXEN	GSCPOL	GSCPHI-SYNCEN	GSCINTEN
0x21	GSCCNTR	Internal clock counter for GSC	GSCCNTR[7:0]							
0x22			GSCCNTR[15:8]							
0x23	GSCMUL	GSC multiplier	-	-	-	GSCMUL[4:0]				
0x24	GSCDIV	GSC Divider	GSCDIV[7:0]							

Atmel LED Driver-MSL2162

16-string White and RGB LED Driver with Adaptive Configuration, EEPROM, and SPI Bus

Table 4. Atmel LED Driver-MSL2162 Register Map

ADDRESS AND REGISTER NAME		FUNCTION	REGISTER DATA							
			D7	D6	D5	D4	D3	D2	D1	D0
0x25	GSCMAX	Max oscillator cycles between GSC pulses	GSCMAX[7:0]							
0x26			GSCMAX[15:8]							
0x27	PHICTRL	PHI processing control	PHICHK-SEL	-	-	-	-	PHIMAXEN	PHIPOL	PHIINTEN
0x28	PHICNTR	Internal clock counter for PHI	PHICNTR[7:0]							
0x29			PHICNTR[15:8]							
0x2A	PHIMUL	PHI multiplier	-	-	-	PHIMUL[4:0]				
0x2B	PHIMAX	Min GSC pulses over PHI period	PHIMAX[7:0]							
0x2C			-	-	-	-	PHIMAX[11:8]			
0x2D	PWMCTRL0	PWM control	GINT+1EN	GINTEN	ALTEN	OVRFLOZEN	OVRFLOEN	PWM GLBLEN	PWMDIRECT	PWMEN
0x2E	PWMCTRL1		-	-	-	-	EXTALTEN	PHOVR FLOZEN	PHOVR FLOEN	PHADLYEN
0x2F	GINT	Global PWM scaling	GINT[7:0]							
0x30	ALTGINT	Alternate global PWM scaling	ALTGINT[7:0]							
0x31	ISTR	8-bit global string current	ISTR[7:0]							
0x32	PWMSTATUS	PWM and counter status	PHIMAXERRCNT[2:0]			PHIMAX1FLT	PHIMULFLT	GSCMULFLT	PHICNTRFLT	GINT-MULERR
0x33	PHPCNTR	PHI pulse counter and status	PHICNTR-MAX	-	-	PHIMULCNTR[0:4]				
0x34	GSCPCNTR	GSC pulse counter	GSCPULSECNTR[7:0]							
0x35			-	-	-	GSCPULSECNTR[12:8]				
0x36 THRU 0x3F			UNUSED							
0x40	STR0SET	Phase delay and EO assignment for string 0	PHDLY0[7:0]							
0x41			FBOSET0[1:0]	-	-	PHDLY[11:8]				
↓	↓	↓	↓							
0x5E	STR15SET	Phase delay and EO assignment for string 15	PHDLY15[7:0]							
0x5F			FBOSET15[1:0]	-	-	PHDLY[11:8]				
0x60	PWM0	12-bit PWM setting for string 0	PWM0[7:0]							
0x61			-	-	-	-	PWM0[11:8]			
↓	↓	↓	↓							
0x7E	PWM15	12-bit PWM setting for string 15	PWM15[7:0]							
0x7F			-	-	-	-	PWM15[11:8]			
0x80	ALTSTR0SET	Phase delay and EO assignment for string 0	ALTPHDLY0[7:0]							
0x81			-	-	-	-	ALTPHDLY[11:8]			
↓	↓	↓	↓							
0x9E	ALTSTR15SET	Phase delay and EO assignment for string 15	ALTPHDLY15[7:0]							
0x9F			-	-	-	-	ALTPHDLY[11:8]			
0xA0	ALTPWM0	12-bit PWM setting for string 0	ALTPWM0[7:0]							
0xA1			-	-	-	-	ALTPWM0[11:8]			



ADDRESS AND REGISTER NAME		FUNCTION	REGISTER DATA						
			D7	D6	D5	D4	D3	D2	D1
↓	↓	↓	↓						
0xBE	ALTPWM15	12-bit PWM setting for string 15	ALTPWM15[7:0]						
0xBF			-	-	-	-	ALTPWM15[11:8]		
0xC0	E2ADDR	EEPROM read/write access	-	E2ADDR[6:0]					
0xC1	E2CTRLSTA		E2BUSY	BLDACT	E2ERR	-	-	RWCTRL[2:0]	

*** Read-Only Registers**

Register Power-up Defaults

Register power-up default values are shown in Table 5.

Table 5. Atmel LED Driver-MSL2162 Register Power-Up Defaults

REGISTER NAME AND ADDRESS		POWER- UP CONDITION REGISTERS INITIALIZED FROM E ² PROM	REGISTER DATA							HEX										
			D7	D6	D5	D4	D3	D2	D1		D0									
0x00	STRINGEN0	All LED String Drive Outputs Enabled	1	1	1	1	1	1	1	1	1	1	1	1	1	1	1	1	FF	
0x01	STRINGEN1		1	1	1	1	1	1	1	1	1	1	1	1	1	1	1	1	1	FF
0x02	CONFIG	String short circuit confirmation delay = 8µs String current fold-back disabled Device is not asleep	0	0	0	0	0	0	0	0	0	0	0	0	0	0	0	0	00	
0x03	FLTEN	FBO open circuit fault detect globally enabled String open circuit fault detect globally enabled LED short circuit fault detect globally enabled GSC max fault detect globally disabled PHI max fault detect globally disabled	0	0	0	0	0	1	1	1	1	1	1	1	1	1	1	1	07	
0x04	STRFLTEN0	Fault detection individually enabled for all strings	1	1	1	1	1	1	1	1	1	1	1	1	1	1	1	1	FF	
0x05	STRFLTEN1		1	1	1	1	1	1	1	1	1	1	1	1	1	1	1	1	FF	
0x0F	OSCFREQ	f _{osc} = 20MHz	0	0	0	0	0	1	0	0	0	0	0	0	0	0	0	0	04	
0x10	FBOCTRL0	Current sink error confirmation delay = 2µs FBO power supply settling time allowance = 4ms Efficiency Optimizer auto-recalibration occurs every 1 second Efficiency Optimizer headroom steps = 3	0	1	0	0	1	0	0	0	0	0	0	0	0	0	0	0	1	49
0x11	FBOCTRL1	MOSFET current sink error detection enabled Efficiency Optimizer auto-recalibration enabled PWM settings used during auto-recalibration PWM settings used during initial calibration	0	0	0	1	1	0	1	0	1	0	0	0	0	0	0	0	0	4A
0x12	FBOCTRL2	Efficiency Optimizer correction step size = 1 LSBs (1µA) Efficiency Optimizer initial calibration step size = 1 LSBs (1µA) FBO outputs are globally enabled Open circuit detection enabled for both FBO outputs	0	0	0	0	0	0	1	1	1	1	1	1	1	1	1	1	07	
0x20	GSCCTRL	External signal at GSC is selected for input to the PWM engine GSC not internally synchronized to PHI pGSC is synchronized to falling edge of external GSC signal GSC maximum count fault detect is disabled Although disabled, GSC max fault monitors pGSC	0	0	0	0	0	0	0	0	0	0	0	0	0	0	0	0	00	
0x21	GSCCNTR	Although disabled, internal GSC frequency is set to 20MHz / (19 + 1) = 1.0MHz	0	0	0	1	0	0	0	1	1	1	1	1	1	1	1	1	13	
0x22			0	0	0	0	0	0	0	0	0	0	0	0	0	0	0	0	00	
0x23	GSCMUL	GSC multiplexer output is multiplied by 4 (register setting + 1)	0	0	0	0	0	0	0	0	1	1	1	1	1	1	1	1	03	
0x24	GSCDIV	GSC multiplier output is divided by 1 (register setting + 1)	0	0	0	0	0	0	0	0	0	0	0	0	0	0	0	0	00	
0x25	GSCMAX	Although disabled, GSC max count is set to 19 clock cycles	0	0	0	1	0	0	0	1	1	1	1	1	1	1	1	1	13	
0x26			0	0	0	0	0	0	0	0	0	0	0	0	0	0	0	0	00	

Atmel LED Driver-MSL2162

16-string White and RGB LED Driver with Adaptive Configuration, EEPROM, and SPI Bus

REGISTER NAME AND ADDRESS		POWER- UP CONDITION REGISTERS INITIALIZED FROM E ² PROM	REGISTER DATA							HEX	
			D7	D6	D5	D4	D3	D2	D1		D0
0x28	PHICNTR	Although disabled, internal PHI frequency is set to 20MHz / (8 * (10416 + 1)) = 240Hz	1	0	1	1	0	0	0	0	B0
0x29			0	0	1	0	1	0	0	0	28
0x2A	PHIMUL	PHI multiplier = 1 (register setting + 1)	0	0	0	0	0	0	0	0	00
0x2B	PHIMAX	Although disabled, PHI max count is zero	0	0	0	0	0	0	0	0	00
0x2C			0	0	0	0	0	0	0	0	00
0x2D	PWMCTRL0	PWM operation enabled Individual LED string drive pulse widths internally determined PWM input does not gate the output of the PWM engine String on-times allowed to extend beyond end of PWM frame String on-times not allowed to extend into frame zero	1	0	0	0	1	0	0	1	89
0x2E	PWMCTRL1	Alternate timing not used Global intensity (GINT) disabled Although disabled, (GINT + 1) is provided to the PWM engine String drive phasing enabled Delayed string turn-on beginning after PWM frame not allowed Alternate timing not selected by PWM input state	0	0	0	0	0	0	0	1	01
0x2F	GINT	Although disabled, global intensity set to (127 + 1) / 256 = 50% (1 added in numerator because bit D7 of 0x2D = 1)	0	1	1	1	1	1	1	1	7F
0x30	ALTGINT	Although disabled, Alternate global intensity set to (127 + 1) / 256 = 50% (1 added in numerator because bit D7 of 0x2D = 1)	0	1	1	1	1	1	1	1	7F
0x31	ISTR	Strings current globally scaled to 50% of R _{sn} setting	0	1	1	1	1	1	1	1	7F
0x40	STROSET	All strings set to zero phase delay with strings assigned to FBO outputs as follows: FBO1: All Strings FBO2: No Strings	0	0	0	0	0	0	0	0	00
0x41			0	1	0	0	0	0	0	0	40
-								
0x5E	STR15SET	FBO1: All Strings FBO2: No Strings	0	0	0	0	0	0	0	0	00
0x5F			0	1	0	0	0	0	0	0	40
0x60	PWM0	All strings set with PWM t _{ON} = 512 GSC cycles	0	0	0	0	0	0	0	0	00
0x61			0	0	0	0	0	0	1	0	02
-								
0x7E	PWM15	All strings set with PWM t _{ON} = 512 GSC cycles	0	0	0	0	0	0	0	0	00
0x7F			0	0	0	0	0	0	1	0	02
0x80	ALTSTROSET	All strings set with alternate phase delay of zero	0	0	0	0	0	0	0	0	00
0x81			0	0	0	0	0	0	0	0	00
-								
0x9E	ALTSTR15SET	All strings set with alternate phase delay of zero	0	0	0	0	0	0	0	0	00
0x9F			0	0	0	0	0	0	0	0	00
0xA0	ALTPWM0	All strings set with Alternate PWM t _{ON} = 512 GSC cycles	0	0	0	0	0	0	0	0	00
0xA1			0	0	0	0	0	0	1	0	02
-								
0xBE	ALTPWM15	All strings set with Alternate PWM t _{ON} = 512 GSC cycles	0	0	0	0	0	0	0	0	00
0xBF			0	0	0	0	0	0	1	0	02
REGISTERS WITH FIXED INITIAL VALUES											
0xC0	E2ADDR	E ² PROM 7 bit address = 0x00	0	0	0	0	0	0	0	0	00
0xC1	E2CTRLSTA	E ² PROM read/write disabled	0	0	0	0	0	0	0	0	00

**Atmel Corporation**

2325 Orchard Parkway
San Jose, CA 95131
USA

Tel: (+1)(408) 441-0311

Fax: (+1)(408) 487-2600

www.atmel.com

Atmel Asia Limited

Unit 01-5 & 16, 19F
BEA Tower, Millennium City 5
418 Kwun Tong Road
Kwun Tong, Kowloon
HONG KONG

Tel: (+852) 2245-6100

Fax: (+852) 2722-1369

Atmel Munich GmbH

Business Campus
Parking 4
D-85748 Garching b. Munich
GERMANY

Tel: (+49) 89-31970-0

Fax: (+49) 89-3194621

Atmel Japan

9F, Tonetsu Shinkawa Bldg.
1-24-8 Shinkawa
Chuo-ku, Tokyo 104-0033
JAPAN

Tel: (+81)(3) 3523-3551

Fax: (+81)(3) 3523-7581

© 2011 Atmel Corporation. All rights reserved. / Rev.: MEM-MSL2162DB1-E-US_06-11

Atmel®, logo and combinations thereof, and others are registered trademarks or trademarks of Atmel Corporation or its subsidiaries. Other terms and product names may be trademarks of others.

Disclaimer: The information in this document is provided in connection with Atmel products. No license, express or implied, by estoppel or otherwise, to any intellectual property right is granted by this document or in connection with the sale of Atmel products. EXCEPT AS SET FORTH IN THE ATMEL TERMS AND CONDITIONS OF SALES LOCATED ON THE ATMEL WEBSITE, ATMEL ASSUMES NO LIABILITY WHATSOEVER AND DISCLAIMS ANY EXPRESS, IMPLIED OR STATUTORY WARRANTY RELATING TO ITS PRODUCTS INCLUDING, BUT NOT LIMITED TO, THE IMPLIED WARRANTY OF MERCHANTABILITY, FITNESS FOR A PARTICULAR PURPOSE, OR NON-INFRINGEMENT. IN NO EVENT SHALL ATMEL BE LIABLE FOR ANY DIRECT, INDIRECT, CONSEQUENTIAL, PUNITIVE, SPECIAL OR INCIDENTAL DAMAGES (INCLUDING, WITHOUT LIMITATION, DAMAGES FOR LOSS AND PROFITS, BUSINESS INTERRUPTION, OR LOSS OF INFORMATION) ARISING OUT OF THE USE OR INABILITY TO USE THIS DOCUMENT, EVEN IF ATMEL HAS BEEN ADVISED OF THE POSSIBILITY OF SUCH DAMAGES. Atmel makes no representations or warranties with respect to the accuracy or completeness of the contents of this document and reserves the right to make changes to specifications and products descriptions at any time without notice. Atmel does not make any commitment to update the information contained herein. Unless specifically provided otherwise, Atmel products are not suitable for, and shall not be used in, automotive applications. Atmel products are not intended, authorized, or warranted for use as components in applications intended to support or sustain life.