

FEATURES

- Four Independent Sample-and-Holds
- Internal Hold Capacitors
- High Accuracy: 12 Bit
- Very Low Droop Rate: 2 mV/s typ
- Output Buffers Stable for $C_L \leq 500$ pF
- TTL/CMOS Compatible Logic Inputs
- Single or Dual Supply Applications
- Monolithic Low Power CMOS Design

APPLICATIONS

- Signal Processing Systems
- Multichannel Data Acquisition Systems
- Automatic Test Equipment
- Medical and Analytical Instrumentation
- Event Analysis
- DAC Deglitching

FUNCTIONAL BLOCK DIAGRAM

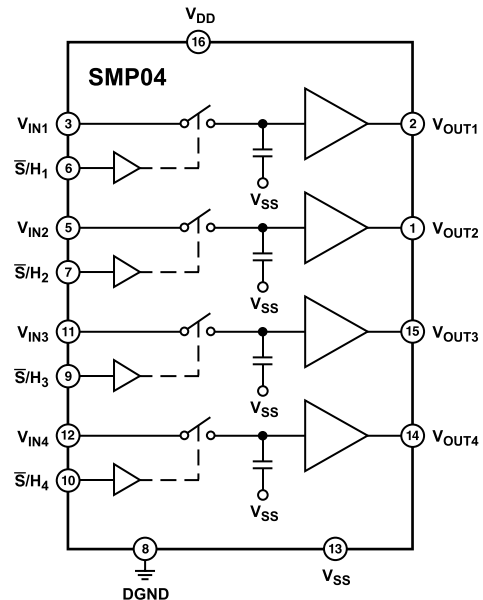

GENERAL DESCRIPTION

The SMP04 is a monolithic quad sample-and-hold; it has four internal precision buffer amplifiers and internal hold capacitors. It is manufactured in ADI's advanced oxide isolated CMOS technology to obtain the high accuracy, low droop rate and fast acquisition time required by data acquisition and signal processing systems. The device can acquire an 8-bit input signal to $\pm 1/2$ LSB in less than four microseconds. The SMP04 can operate from single or dual power supplies with TTL/CMOS logic compatibility. Its output swing includes the negative supply.

The SMP04 is ideally suited for a wide variety of sample-and-hold applications, including amplifier offset or VCA gain adjustments. One or more can be used with single or multiple DACs to provide multiple setpoints within a system.

The SMP04 offers significant cost and size reduction over equivalent module or discrete designs. It is available in a 16-lead hermetic or plastic DIP and surface mount SOIC packages. It is specified over the extended industrial temperature range of -40°C to $+85^{\circ}\text{C}$.

REV. D

Information furnished by Analog Devices is believed to be accurate and reliable. However, no responsibility is assumed by Analog Devices for its use, nor for any infringements of patents or other rights of third parties which may result from its use. No license is granted by implication or otherwise under any patent or patent rights of Analog Devices.

SMP04—SPECIFICATIONS

ELECTRICAL CHARACTERISTICS (@ $V_{DD} = +12.0\text{ V}$, $V_{SS} = \text{DGND} = 0\text{ V}$, $R_L = \text{No Load}$, $T_A = \text{Operating Temperature Range}$ specified in Absolute Maximum Ratings, unless otherwise noted.)

Parameter	Symbol	Conditions	Min	Typ	Max	Units
Linearity Error	V_{OS}	$V_{IN} = 6\text{ V}$		0.01		%
Buffer Offset Voltage	V_{OS}	$V_{IN} = 6\text{ V}$, $T_A = +25^\circ\text{C}$ to $+85^\circ\text{C}$	-10	± 2.5	+10	mV
Hold Step	V_{HS}	$V_{IN} = 6\text{ V}$, $T_A = -40^\circ\text{C}$		2.5	4	mV
Droop Rate	$\Delta V/\Delta t$	$V_{IN} = 6\text{ V}$, $T_A = +25^\circ\text{C}$		2	25	mV/s
Output Source Current ¹	I_{SOURCE}	$V_{IN} = 6\text{ V}$	1.2			mA
Output Sink Current ¹	I_{SINK}	$V_{IN} = 6\text{ V}$	0.5			mA
Output Voltage Range	OVR	$R_L = 20\text{ k}\Omega$	0.06		10.0	V
		$R_L = 10\text{ k}\Omega$	0.06		9.5	V
LOGIC CHARACTERISTICS						
Logic Input High Voltage	V_{INH}		2.4			V
Logic Input Low Voltage	V_{INL}				0.8	V
Logic Input Current	I_{IN}			0.5	1	μA
DYNAMIC PERFORMANCE²						
Acquisition Time ³	t_{AQ}	$T_A = +25^\circ\text{C}$, 0 V to 10 V Step to 0.1% $-40^\circ\text{C} \leq T_A \leq +85^\circ\text{C}$		3.5	4.25	μs
Acquisition Time ³	t_{AQ}	$T_A = +25^\circ\text{C}$, 0 V to 10 V Step to 0.01%		3.75	5.25	μs
Hold Mode Settling Time	t_H	To 1 mV		9		μs
Slew Rate ⁴	SR	$R_L = 20\text{ k}\Omega$	3	4		V/ μs
Capacitive Load Stability	C_L	<30% Overshoot		500		pF
Analog Crosstalk		0 V to 10 V Step		-80		dB
SUPPLY CHARACTERISTICS						
Power Supply Rejection Ratio	PSRR	$10.8\text{ V} \leq V_{DD} \leq 13.2\text{ V}$	60	75		dB
Supply Current	I_{DD}			4	7	mA
Power Dissipation	P_{DIS}				84	mW

ELECTRICAL CHARACTERISTICS (@ $V_{DD} = +5.0\text{ V}$, $V_{SS} = -5.0\text{ V}$, $\text{DGND} = 0.0\text{ V}$, $R_L = \text{No Load}$, $T_A = \text{Operating Temperature Range}$ specified in Absolute Maximum Ratings, unless otherwise noted.)

Parameter	Symbol	Conditions	Min	Typ	Max	Units
Linearity Error	V_{OS}	$V_{IN} = 0\text{ V}$		0.01		%
Buffer Offset Voltage	V_{OS}	$V_{IN} = 0\text{ V}$, $T_A = +25^\circ\text{C}$ to $+85^\circ\text{C}$	-10	± 2.5	+10	mV
Hold Step	V_{HS}	$V_{IN} = 0\text{ V}$, $T_A = -40^\circ\text{C}$		2.5	4	mV
Droop Rate	$\Delta V/\Delta t$	$V_{IN} = 0\text{ V}$, $T_A = +25^\circ\text{C}$		2	25	mV/s
Output Resistance	R_{OUT}	$V_{IN} = 0\text{ V}$		1		Ω
Output Source Current ¹	I_{SOURCE}	$V_{IN} = 0\text{ V}$	1.2			mA
Output Sink Current ¹	I_{SINK}	$V_{IN} = 0\text{ V}$	0.5			mA
Output Voltage Range	OVR	$R_L = 20\text{ k}\Omega$	-3.0		+3.0	V
LOGIC CHARACTERISTICS						
Logic Input High Voltage	V_{INH}		2.4			V
Logic Input Low Voltage	V_{INL}				0.8	V
Logic Input Current	I_{IN}			0.5	1	μA
DYNAMIC PERFORMANCE²						
Acquisition Time ³	t_{AQ}	-3 V to +3 V Step to 0.1%		3.6	11	μs
Acquisition Time ³	t_{AQ}	-3 V to +3 V Step to 0.01%		9		μs
Hold Mode Settling Time	t_H	To 1 mV		1		μs
Slew Rate ⁵	SR	$R_L = 20\text{ k}\Omega$		3		V/ μs
Capacitive Load Stability	C_L	<30% Overshoot	500			pF
SUPPLY CHARACTERISTICS						
Power Supply Rejection Ratio	PSRR	$\pm 5\text{ V} \leq V_{DD} \leq \pm 6\text{ V}$	60	75		dB
Supply Current	I_{DD}			3.5	5.5	mA
Power Dissipation	P_{DIS}				55	mW

NOTES

¹Outputs are capable of sinking and sourcing over 20 mA, but linearity and offset are guaranteed at specified load levels.

²All input control signals are specified with $t_R = t_F = 5\text{ ns}$ (10% to 90% of +5 V) and timed from a voltage level of 1.6 V.

³This parameter is guaranteed without test.

⁴Slew rate is measured in the sample mode with a 0 V to 10 V step from 20% to 80%.

⁵Slew rate is measured in the sample mode with a -3 V to +3 V step from 20% to 80%.

Specifications are subject to change without notice.

ABSOLUTE MAXIMUM RATINGS

($T_A = +25^\circ\text{C}$ unless otherwise noted)

V_{DD} to DGND	-0.3 V, 17 V
V_{DD} to V_{SS}	-0.7 V, 17 V
V_{LOGIC} to DGND	-0.3 V, V_{DD}
V_{IN} to DGND	V_{SS} , V_{DD}
V_{OUT} to DGND	V_{SS} , V_{DD}
Analog Output Current	± 20 mA
(Not Short-Circuit Protected)		
Digital Input Voltage to DGND	-0.3 V, $V_{DD} + 0.3$ V
Operating Temperature Range		
EQ, EP, ES	-40°C to $+85^\circ\text{C}$
Junction Temperature	$+150^\circ\text{C}$
Storage Temperature	-65°C to $+150^\circ\text{C}$
Lead Temperature (Soldering, 60 sec)	$+300^\circ\text{C}$

PIN CONNECTIONS

16-Lead Cerdip
16-Lead Plastic DIP
16-Lead SO

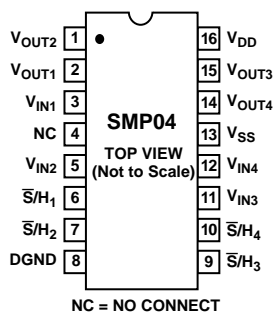

Package Type	θ_{JA}^*	θ_{JC}	Units
16-Lead Cerdip	94	12	$^\circ\text{C}/\text{W}$
16-Lead Plastic DIP	76	33	$^\circ\text{C}/\text{W}$
16-Lead SO	92	27	$^\circ\text{C}/\text{W}$

* θ_{JA} is specified for worst case mounting conditions, i.e., θ_{JA} is specified for device in socket for cerdip and plastic DIP packages; θ_{JA} is specified for device soldered to printed circuit board for SO package.

CAUTION

- Stresses above those listed under Absolute Maximum Ratings may cause permanent damage to the device. This is a stress rating only; function operation at or above this specification is not implied. Exposure to the above maximum rating conditions for extended periods may affect device reliability.
- Digital inputs and outputs are protected; however, permanent damage may occur on unprotected units from high energy electrostatic fields. Keep units in conductive foam or packaging at all times until ready to use. Use proper antistatic handling procedures.
- Remove power before inserting or removing units from their sockets.

ORDERING GUIDE

Model	Temperature Range	Package Description	Package Options*
SMP04EQ	-40°C to $+85^\circ\text{C}$	Cerdip-16	Q-16
SMP04EP	-40°C to $+85^\circ\text{C}$	PDIP-16	N-16
SMP04ES	-40°C to $+85^\circ\text{C}$	SO-16	R-16A

*Q = Cerdip; N = Plastic DIP; R = Small Outline.

CAUTION

ESD (electrostatic discharge) sensitive device. Electrostatic charges as high as 4000 V readily accumulate on the human body and test equipment and can discharge without detection. Although the SMP04 features proprietary ESD protection circuitry, permanent damage may occur on devices subjected to high energy electrostatic discharges. Therefore, proper ESD precautions are recommended to avoid performance degradation or loss of functionality.



SMP04

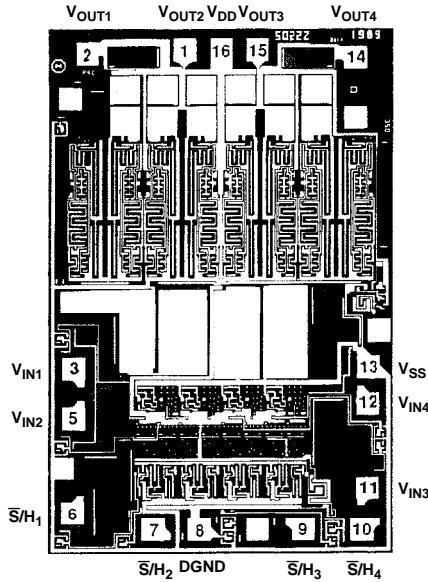

Dice Characteristics
Die Size: 0.80 x 0.120 mil = 9,600 sq. mil
(2.032 x 3.048mm = 6.193 sq. mm)

WAFER TEST LIMITS (@ $V_{DD} = +12\text{ V}$, $V_{SS} = \text{DGND} = 0\text{ V}$, $R_L = \text{No Load}$, $T_A = +25^\circ\text{C}$, unless otherwise noted.)

Parameter	Symbol	Conditions	SMP04G Limits	Units
Buffer Offset Voltage	V_{OS}	$V_{IN} = +6\text{ V}$	± 10	mV max
Hold Step	V_{HS}	$V_{IN} = +6\text{ V}$	± 4	mV max
Droop Rate	$\Delta V/\Delta t$	$V_{IN} = +6\text{ V}$	25	mV/s max
Output Source Current	I_{SOURCE}	$V_{IN} = +6\text{ V}$	1.2	mA min
Output Sink Current	I_{SINK}	$V_{IN} = +6\text{ V}$	0.5	mA min
Output Voltage Range	OVR	$R_L = 20\text{ k}\Omega$	0.06/10.0	V min/max
		$R_L = 10\text{ k}\Omega$	0.06/9.5	V min/max
LOGIC CHARACTERISTICS				
Logic Input High Voltage	V_{INH}		2.4	V min
Logic Input Low Voltage	V_{INL}		0.8	V max
Logic Input Current	I_{IN}		1	μA max
SUPPLY CHARACTERISTICS				
Power Supply Rejection Ratio	PSRR	$10.8\text{ V} \leq V_{DD} \leq 13.2\text{ V}$	60	dB min
Supply Current	I_{DD}		7	mA max
Power Dissipation	P_{DIS}		84	mW max

NOTE
 Electrical tests are performed at wafer probe to the limits shown. Due to variations in assembly methods and normal yield loss, yield after packaging is not guaranteed for standard product dice. Consult factory to negotiate specifications based on dice lot qualifications through sample lot assembly and testing.

Typical Performance Characteristics—SMP04

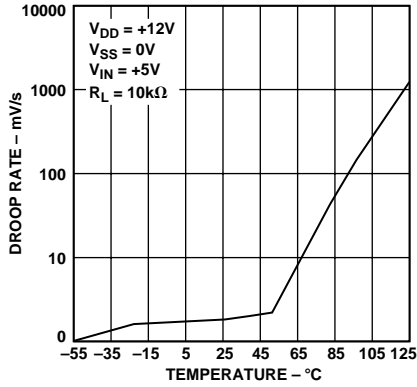

Figure 1. Droop Rate vs. Temperature

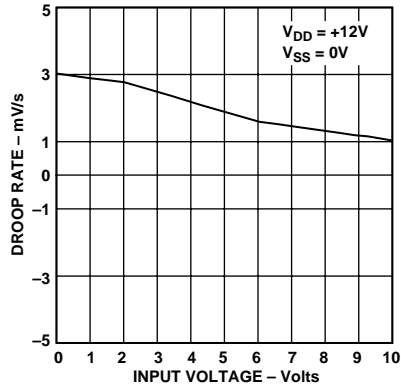

Figure 2. Droop Rate vs. Input Voltage ($T_A = +25^\circ\text{C}$)

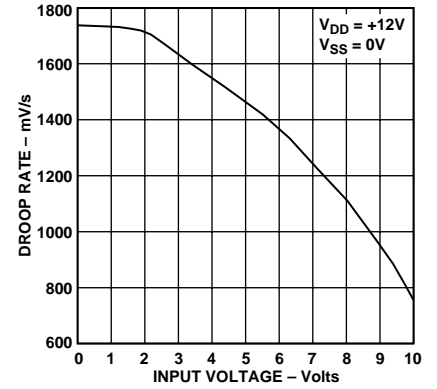

Figure 3. Droop Rate vs. Input Voltage ($T_A = +125^\circ\text{C}$)

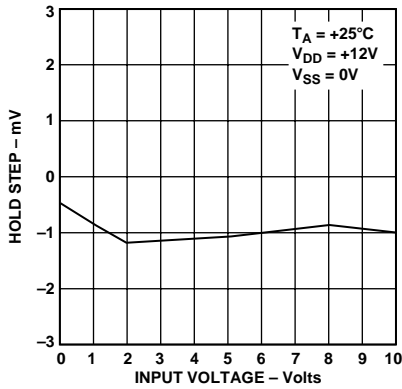

Figure 4. Hold Step vs. Input Voltage

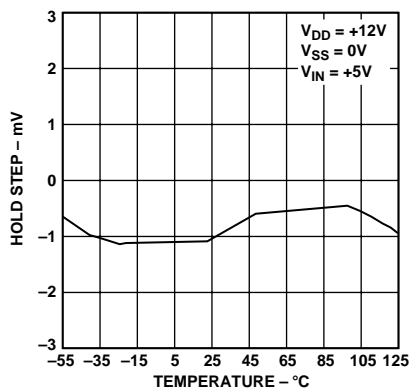

Figure 5. Hold Step vs. Temperature

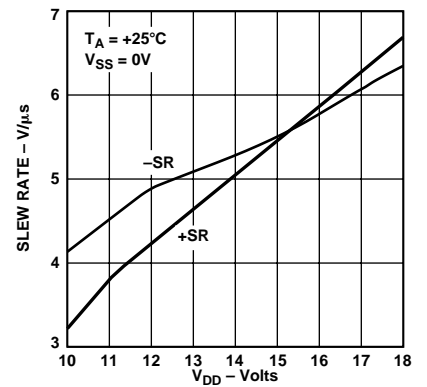

Figure 6. Slew Rate vs. V_{DD}

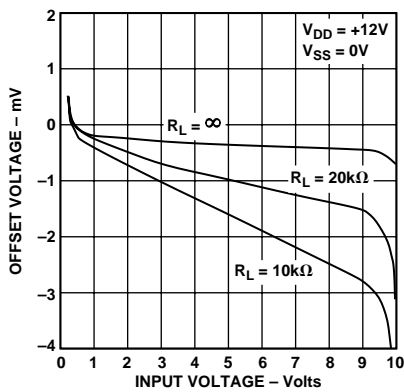

Figure 7. Offset Voltage vs. Input Voltage ($T_A = +25^\circ\text{C}$)

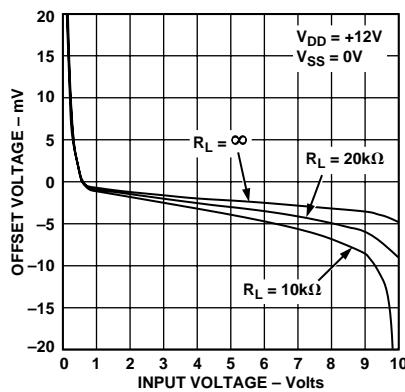

Figure 8. Offset Voltage vs. Input Voltage ($T_A = +125^\circ\text{C}$)

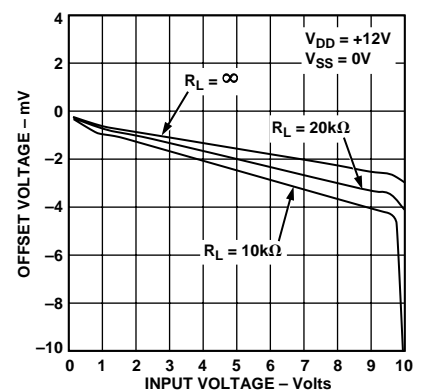

Figure 9. Offset Voltage vs. Input Voltage ($T_A = -55^\circ\text{C}$)

SMP04

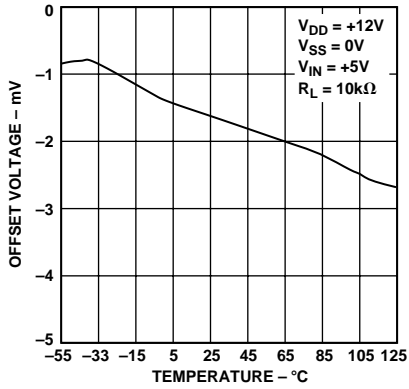

Figure 10. Offset Voltage vs. Temperature

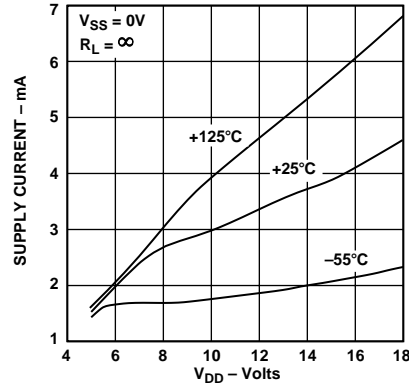

Figure 11. Supply Current vs. V_{DD}

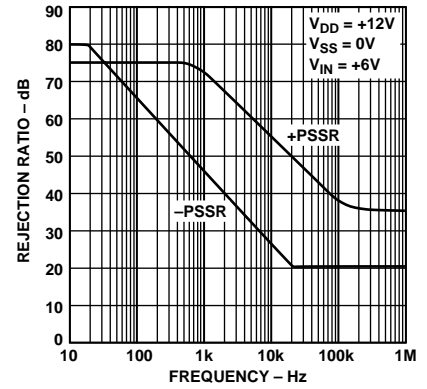

Figure 12. Sample Mode Power Supply Rejection

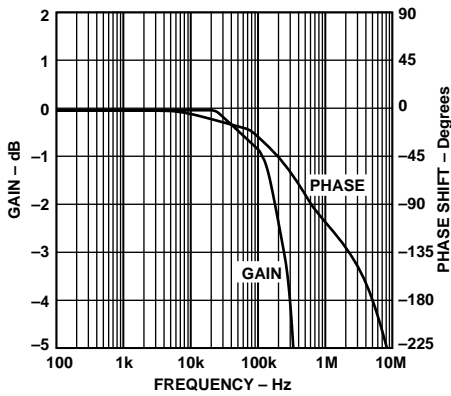

Figure 13. Gain, Phase Shift vs. Frequency

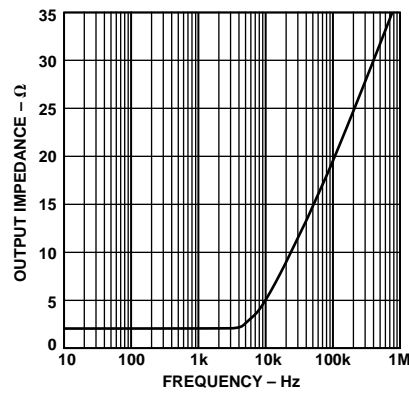

Figure 14. Output Impedance vs. Frequency

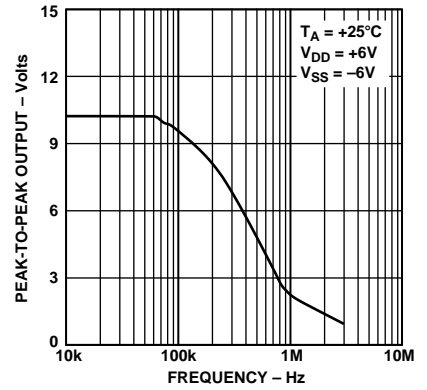

Figure 15. Maximum Output Voltage vs. Frequency

GENERAL INFORMATION

The SMP04 is a quad sample-and-hold with each track-and-hold having its own input, output, control, and on-chip hold capacitor. The combination of four high performance track-and-hold capacitors on a single chip greatly reduces board space and design time while increasing reliability.

After the device selection, the primary considerations in using track-and-holds are the hold capacitor and layout. The SMP04 eliminates most of these problems by having the hold capacitors internal, eliminating the problems of leakage, feedthrough, guard ring layout and dielectric absorption.

POWER SUPPLIES

The SMP04 is capable of operating with either single or dual supplies over a voltage range of 7 to 15 volts. Based on the supply voltages chosen, V_{DD} and V_{SS} establish the output voltage range, which is:

$$V_{SS} + 0.05 V \leq V_{OUT} \leq V_{DD} - 2 V$$

Note that several specifications, including acquisition time, offset and output voltage compliance will degrade for a total supply voltage of less than 7 V. Positive supply current is typically 4 mA with the outputs unloaded. The SMP04 has an internally regulated TTL supply so that TTL/CMOS compatibility will be maintained over the full supply range.

Single Supply Operation Grounding Considerations

In single supply applications, it is extremely important that the V_{SS} (negative supply) pin be connected to a clean ground. This is because the hold capacitor is internally tied to V_{SS} . Any noise or disturbance in the ground will directly couple to the output of the sample-and-hold, degrading the signal-to-noise performance. It is advisable that the analog and digital ground traces on the circuit board be physically separated to reduce digital switching noise from entering the analog circuitry.

Power Supply Bypassing

For optimum performance, the V_{DD} supply pin must also be bypassed with a good quality, high frequency ceramic capacitor. The recommended value is 0.1 μF . In the case where dual supplies are used, V_{SS} (negative supply) bypassing is particularly important. Again this is because the internal hold capacitor is tied to V_{SS} . Good bypassing prevents high frequency noise from entering the sample-and-hold amplifier. A 0.1 μF ceramic bypass capacitor is generally sufficient. For high noise environments, adding a 10 μF tantalum capacitor in parallel with the 0.1 μF provides additional protection.

Power Supply Sequencing

It may be advisable to have the V_{DD} turn on prior to having logic levels on the inputs. The SMP04 has been designed to be resistant to latch-up, but standard precautions should still be taken.

OUTPUT BUFFERS (Pins 1, 2, 14 and 15)

The buffer offset specification is ± 10 mV; this is less than 1/2 LSB of an 8-bit DAC with 10 V full scale. Change in offset over the output range is typically 3 mV. The hold step is the magnitude of the voltage step caused when switching from sample-to-hold mode. This error is sometimes referred to as the pedestal error or sample-to-hold offset, and is about 2 mV with little variation. The droop rate of a held channel is 2 $\mu\text{V}/\text{ms}$ typical and ± 25 $\mu\text{V}/\text{ms}$ maximum.

The buffers are designed primarily to drive loads connected to ground. The outputs can source more than 1.2 mA each, over the full voltage range and maintain specified accuracy. In split supply operation, symmetrical output swings can be obtained by restricting the output range to 2 V from either supply.

On-chip SMP04 buffers eliminate potential stability problems associated with external buffers; outputs are stable with capacitive loads up to 500 pF. However, since the SMP04's buffer outputs are not short-circuit protected, care should be taken to avoid shorting any output to the supplies or ground.

SIGNAL INPUT (Pins 3, 5, 11 and 12)

The signal inputs should be driven from a low impedance voltage source such as the output of an op amp. The op amp should have a high slew rate and fast settling time if the SMP04's fast acquisition time characteristics are to be maintained. As with all CMOS devices, all input voltages should be kept within range of the supply rails ($V_{SS} \leq V_{IN} \leq V_{DD}$) to avoid the possibility of setting up a latch-up condition.

The internal hold capacitance is typically 60 pF and the internal switch ON resistance is 2 k Ω .

If single supply operation is desired, op amps such as the OP183 or AD820, that have input and output voltage compliances including ground, can be used to drive the inputs. Split supplies, such as ± 7.5 V, can be used with the SMP04 and the above mentioned op amps.

APPLICATION TIPS

All unused digital inputs should be connected to logic LOW and the analog inputs connected to analog ground. For connectors or driven analog inputs that may become temporarily disconnected, a resistor to V_{SS} or analog ground should be used with a value ranging from 0.2 M Ω to 1 M Ω .

Do not apply signals to the SMP04 with power off unless the input current's value is limited to less than 10 mA.

Track-and-holds are sensitive to layout and physical connections. For the best performance, the SMP04 should not be socketed.

SMP04

FREQUENCY DOMAIN PERFORMANCE

The SMP04 has been characterized in the frequency domain for those applications that require capture of dynamic signals. See Figure 16a for typical 86.1 kHz sample rate and an 8 kHz input signal. Typically, the SMP04 can sample at rates up to 85 kHz. In addition to the maximum sample rate, a minimum sample pulsewidth will also be acceptable for a given design. Our testing shows a drop in performance as the sample pulsewidth becomes less than 4 μ s.

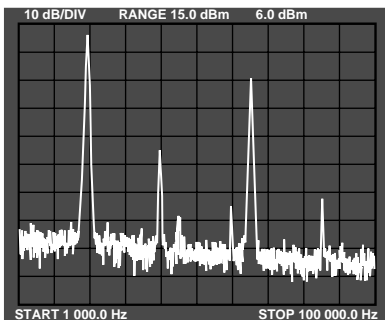

a.

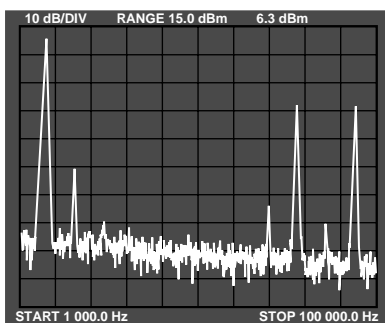

b.

Figure 16. Spectral Response at a Sampling Frequency of 86 kHz. Photo (a) Shows a 20 kHz Carrier Frequency and Photo (b) Shows an 8 kHz Frequency.

Optimizing Dynamic Performance of the SMP04

Various operating parameters such as input voltage amplitude, sampling pulsewidth and, as mentioned before, supply bypassing and grounding all have an effect on the signal-to-noise ratio. Table I shows the SNR versus input level for the SMP04.

Distortion of the SMP04 is reduced by increasing the supply voltage. This has the effect of increasing the positive slew rate. Table II shows data taken at 12.3 kHz sample rate and 2 kHz input frequency. Total harmonic distortion is dominated by the second and third harmonics.

Table III shows the effect of sampling pulsewidth on the SNR of the SMP04. The recommended operating pulsewidth should be a minimum of 5 μ s to achieve a good balance between acquisition time and SNR for the 1.4 V p-p signal shown. For larger swings the pulsewidth will need to be larger to account for the time required for the signal to slew the additional voltage. This could be used as a method of measuring acquisition time indirectly.

Table I. SNR vs. V_{IN}

Input Voltage (V p-p)	SNR (dB)
1	-61
2	-53
3	-50
4	-47
5	-45
6	-44

Conditions: $V_S = \pm 6$ V, $f_S = 14.4$ kHz, $f_{IN} = 1.8$ kHz, $t_{PW} = 10$ μ s.

Table II. SNR vs. Supply Voltage

Supply Voltage (V)	2nd (dB)	3rd (dB)
10	-49	-62
12	-55	-71
14	-60	-80
15	-62	<-80
16	-63	<-83
17	-65	<-85

Table III. SNR vs. Sample Pulsewidth

Sample Pulsewidth (μ s)	SNR (dB)
1	-37
2	-44
3	-50
4	-54
5	-54.9
6	-55
7	-55.3

Conditions: $V_S = \pm 6$ V, $V_{IN} = 1.4$ V p-p, $f_S = 14.4$ kHz, $f_{IN} = 1.8$ kHz.

Sample-Mode Distortion Characteristics

Although designed as a sample-and-hold, the SMP04 may be used as a straight buffer amplifier by configuring it in a continuous sample mode. This is done by connecting the $\overline{S/H}$ control pin to a logic LOW. Its buffer bandwidth is primarily limited by the distortion content as the signal frequency increases. Figure 17 shows the distortion characteristics of the SMP04 versus frequency. It maintains less than 1% total harmonic distortion over a voiceband of 8 kHz. Output spot noise voltage measures $4 \text{ nV}/\sqrt{\text{Hz}}$ at $f = 1 \text{ kHz}$.

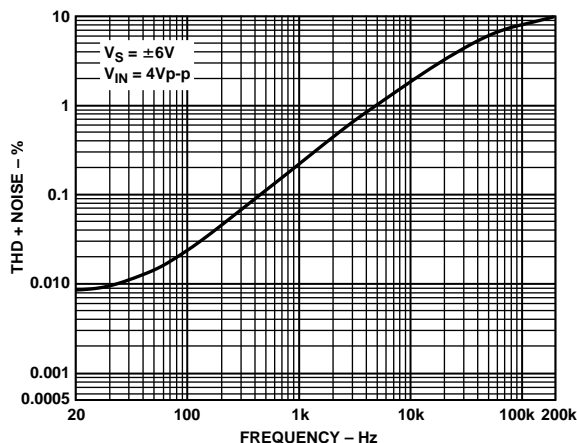

Figure 17. THD+N vs. Frequency

Sampled Data Dynamic Performance

In continuous sampled data applications such as voice digitization or communication circuits, it is important to analyze the spectral response of a sample-and-hold. Figures 16a and 16b show the SMP04 sampling at a frequency of 86 kHz with a 1.4 V p-p pure sine wave input of 20 kHz and 8 kHz respectively. The photos include the sampling carrier frequency as well as its multiplying frequencies. In the case of the 20 kHz carrier frequency, the second harmonic measures 41 dB down from the fundamental, because the second is dominant, the signal-to-noise ratio is -40.9 dB . The 8 kHz case produces an improved S/N performance of -48 dB .

In the V.32 and V.33 modem environment, where a 1.8 kHz carrier signal frequency is applied to the SMP04, Figure 18 compares the spectral responses of the SMP04 under three

different sampling frequencies of 14.4 kHz, 9.6 kHz and 7.2 kHz. The signal-to-noise ratios measure 58.2 dB, 59.3 dB and 60 dB respectively.

Figure 19 depicts SMP04's spectral response operating with voice frequency of 3 kHz sampling at a 15.7 kHz rate. Under this condition, the signal-to-noise measures 53 dB.

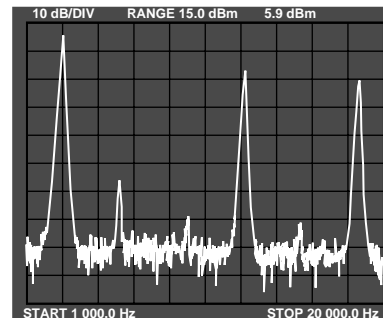

Figure 19. SMP04 Spectral Response with an Input Carrier Frequency of 3 kHz and the Sampling Frequency of 15.7 kHz

Sampled Data Dynamic Performance

In continuous sampled data applications such as voice digitization or communication circuits, it is important to analyze the spectral response of a sample-and-hold. Figures 16a and 16b show the SMP04 sampling at a frequency of 86 kHz with a 1.4 V p-p pure sine wave input of 20 kHz and 8 kHz respectively. The photos include the sampling carrier frequency as well as its multiplying frequencies. In the case of the 20 kHz carrier frequency, the second harmonic measures 41 dB down from the fundamental, because the second is dominant, the signal-to-noise ratio is -40.9 dB . The 8 kHz case produces an improved S/N performance of -48 dB .

In the V.32 and V.33 modem environment, where a 1.8 kHz carrier signal frequency is applied to the SMP04, Figure 18 compares the spectral responses of the SMP04 under three different sampling frequencies of 14.4 kHz, 9.6 kHz and 7.2 kHz. The signal-to-noise ratios measure 58.2 dB, 59.3 dB and 60 dB respectively.

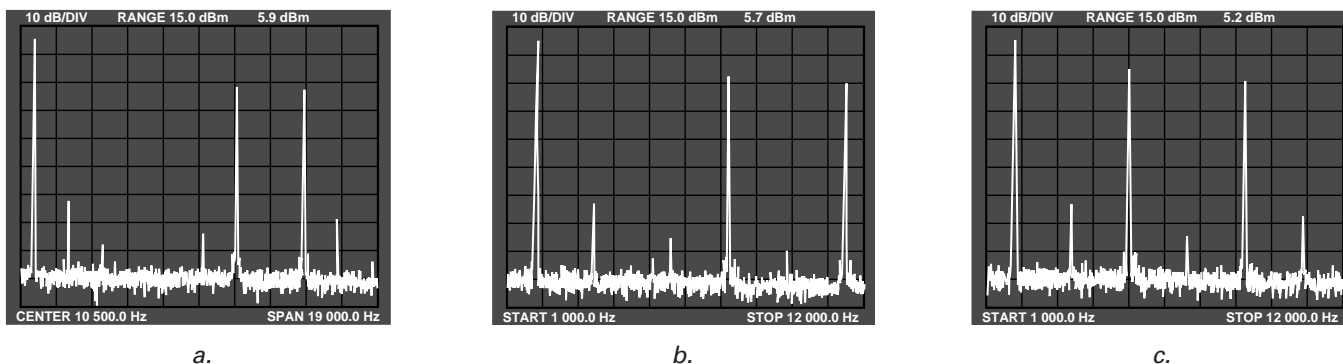

Figure 18. SMP04 Spectral Response with a 1.8 kHz Carrier Frequency. (a) Shows the Sampling Frequency at 14.4 kHz; it Exhibits a S/N Ratio of 58.2 dB. (b) Shows a 59.3 dB S/N at a Sampling Frequency of 8.6 kHz. (c) Shows a 60 dB S/N at 7.2 kHz.

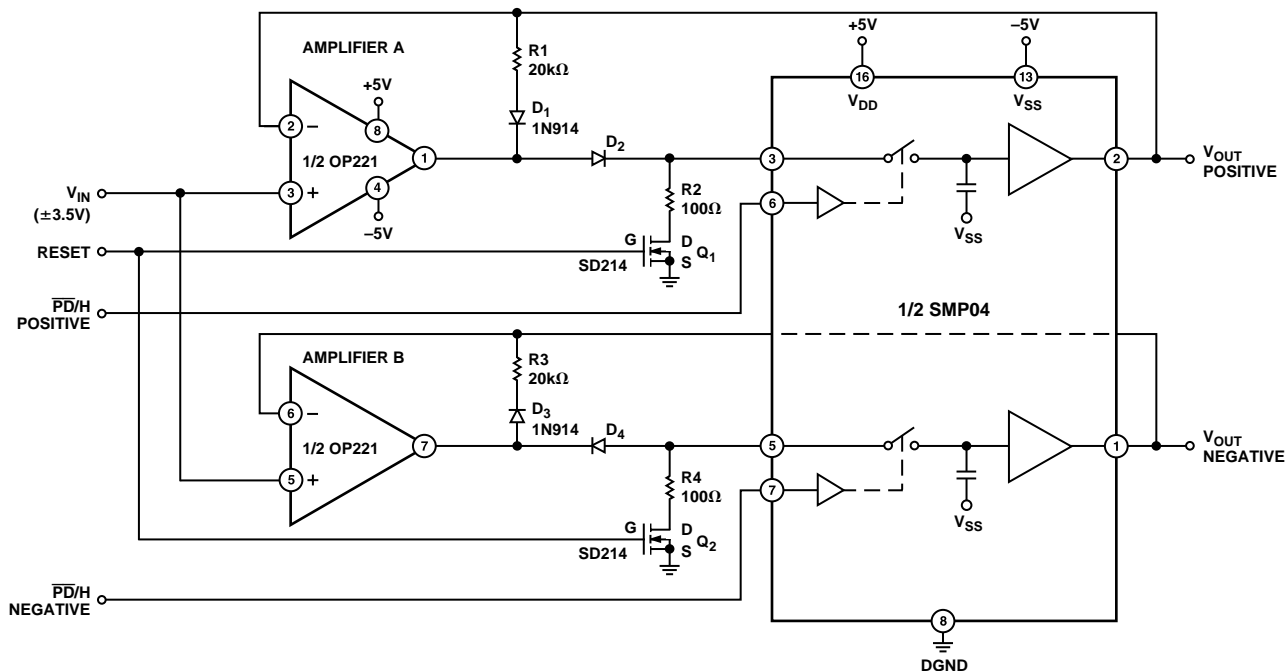

Figure 21. Positive and Negative Peak Detector with Hold Control

POSITIVE AND NEGATIVE PEAK DETECTOR WITH HOLD CONTROL (Figure 21)

In this application the top amplifier (Amplifier A) is the positive peak detector and the bottom amplifier (Amplifier B) is the negative peak detector. Operation can be analyzed as follows: Assume that the \overline{S}/H switch is closed. As a positive increasing voltage is applied to V_{IN} , D_2 turns on, and D_1 turns off, closing the feedback loop around Amplifier A and the SMP04, causing the output to track the input. Conversely, in the negative peak detector circuit at the bottom, D_4 turns off and D_3 turns on, holding the last most negative input voltage on the SMP04. This voltage is buffered to the $V_{O(NEG)}$ output.

As V_{IN} falls in voltage the above conditions reverse, causing the most positive peak voltage to be held at $V_{O(POS)}$ output. This voltage will be held until the input has a more positive voltage than the previously held peak voltage, or a reset condition is applied.

An optional HOLD control can be used by applying a logic HIGH to the \overline{PD}/H inputs. This HOLD mode further reduces leakage current through the reverse-biased diodes (D_2 and D_4) during peak hold.

GAIN OF 10 SAMPLE-AND-HOLD (Figure 22)

This application places the SMP04 in a feedback loop of an amplifier. Because the SMP04 has no sign inversion and the amplifier has very high open-loop gain, the gain of the circuit is set by the ratio of the sum of the source and feedback resistances

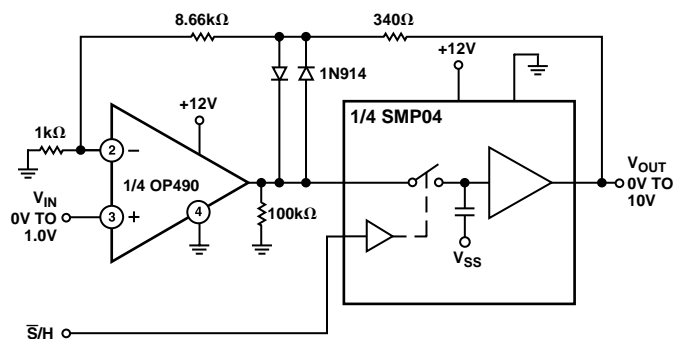

Figure 22. Gain of 10 Sample-and-Hold Amplifier

to the source resistance. When a logic LOW is applied to the \overline{S}/H control input, the loop is closed around the OP490, yielding a gain of 10 (in the example shown) amplifier. When the \overline{S}/H control goes HIGH, the loop opens and the SMP04 holds the last sampled voltage. The loop remains open and the output is unaffected by the input until a logic LOW is reapplied to the \overline{S}/H control. The pair of back-to-back diodes from the output of the op amp to the output of the track-and-hold prevents the op amp from saturating when the track-and-hold is in the hold mode and the loop is open.

SMP04

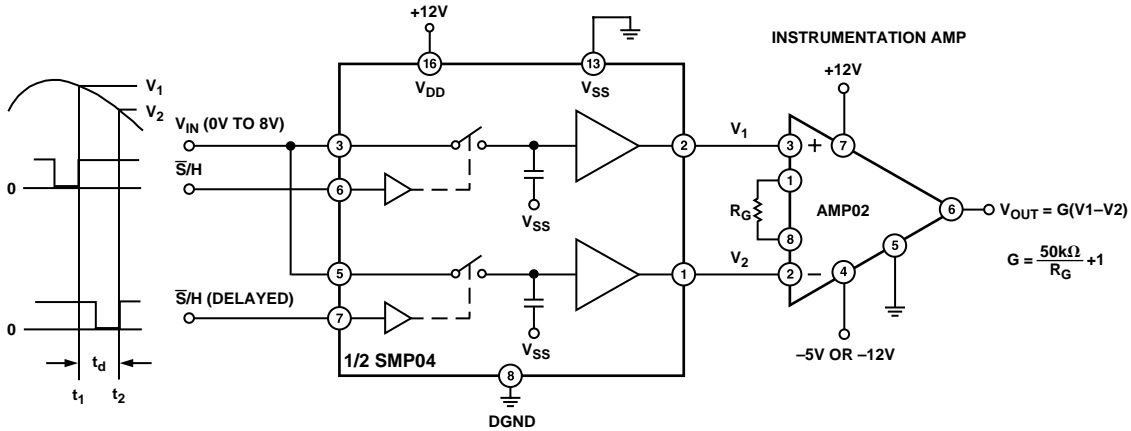

Figure 23. Time Delta Sample-and-Difference Measurement

SAMPLE AND DIFFERENCE AMPLIFIER (Figure 23)

This circuit uses two sample-and-holds to measure the voltage difference of a signal between two time points, t_1 and t_2 . The sampled voltages are fed into the differential inputs of the AMP02 instrumentation amplifier. A single resistor R_G sets the gain of this instrumentation amplifier. Using two channels of the SMP04 in this application has the advantage of matched sample-and-hold performance, since they are both on the same chip.

SINGLE SUPPLY, SAMPLING, INSTRUMENTATION AMPLIFIER (Figure 24)

This application again uses two channels of the SMP04 and an instrumentation amplifier to provide a sampled difference signal. The sample-and-hold signals in this circuit are tied together to sample at the same point in time. The other two parts of the SMP04 are used as amplifiers by grounding their control lines so they are always sampling. One section is used to drive a guard to the common-mode voltage and the other to generate a +6 V reference to serve as an offset for single supply operation.

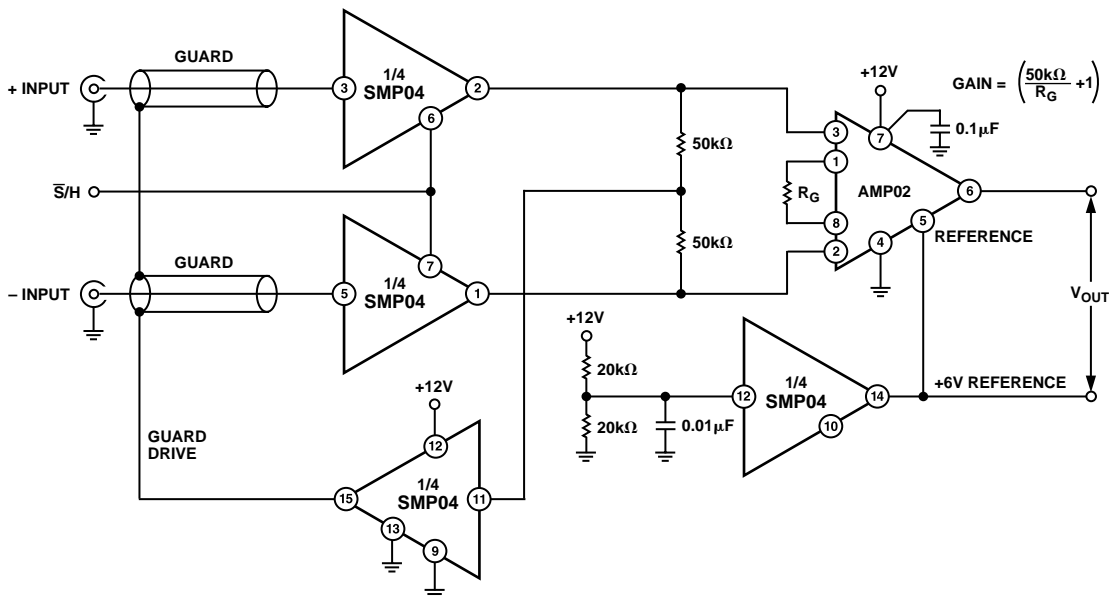

Figure 24. +12 V Single Supply Sampling Instrumentation Amplifier with Guard Drive

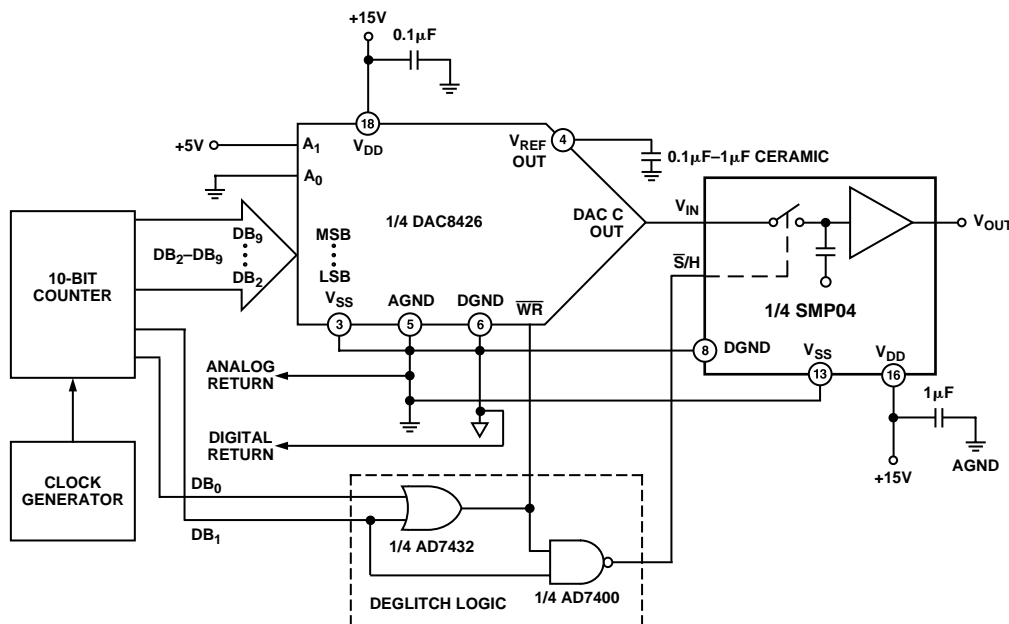
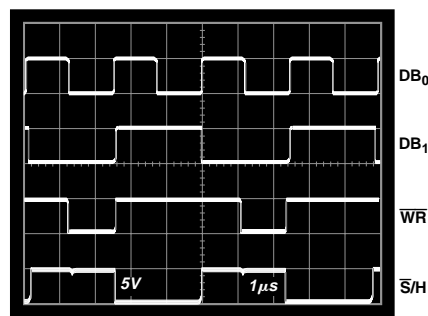

Figure 25. DAC Deglitcher

D/A CONVERTER DEGLITCHER

Most D/A converters output an appreciable amount of glitch energy during a transition from one code to another. The glitch amplitude can range from several millivolts to hundreds of millivolts. This may become unacceptable in many applications. By selectively delaying the DAC's output transition, the SMP04 can be used to smooth the output waveform. Figure 25 shows the schematic diagram of such a deglitcher circuit. Two simple logic gates (an OR and a NAND gate) provide the proper timing sequence for the DAC \overline{WR} strobe and the \overline{S}/H control signal to the SMP04. In this example a linear ramp signal is generated by feeding the most significant eight bits of the 10-bit binary counter to the DAC. The two least significant bits are used to produce the delayed \overline{WR} strobe and the \overline{S}/H control signals. Referring to Figure 26a, new data to the DAC input is set up at the \overline{S}/H 's falling edge, but the DAC output does not change until a \overline{WR} strobe goes active. During this period, the SMP04 is in a sample mode whose output tracks the DAC output. When \overline{S}/H goes HIGH, the current DAC output voltage is held by the SMP04. After 1.2 μs settling, the \overline{WR} strobe goes LOW to allow the DAC output to change. Any glitch that occurs at the DAC output is effectively blocked by the SMP04. As soon as the \overline{WR} strobe goes HIGH, the digital data is latched; at the same time the \overline{S}/H goes LOW, allowing the SMP04 to track to the new DAC output voltage.

Figure 26b shows the deglitching operation. The top trace shows the DAC output during a transition, while the bottom trace shows the deglitched output of the AMP04.



a.

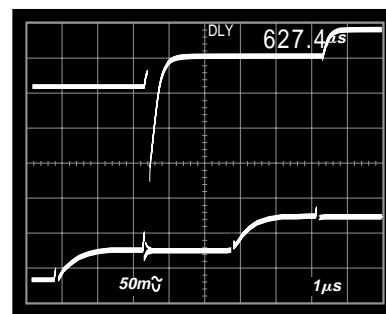

b.

Figure 26. (a) Shows the Logic Timing of the Deglitcher. The Top Two Traces Are the Two Least Significant Bits, DB_0 and DB_1 , Respectively. These Are Used to Generate the \overline{WR} and \overline{S}/H Signals Which Are Shown in the Bottom Two Traces. (b) Shows the Typical Glitch Amplitude of a DAC (Top Trace) and the Deglitched Output of the AMP04 (Bottom Trace).

SMP04

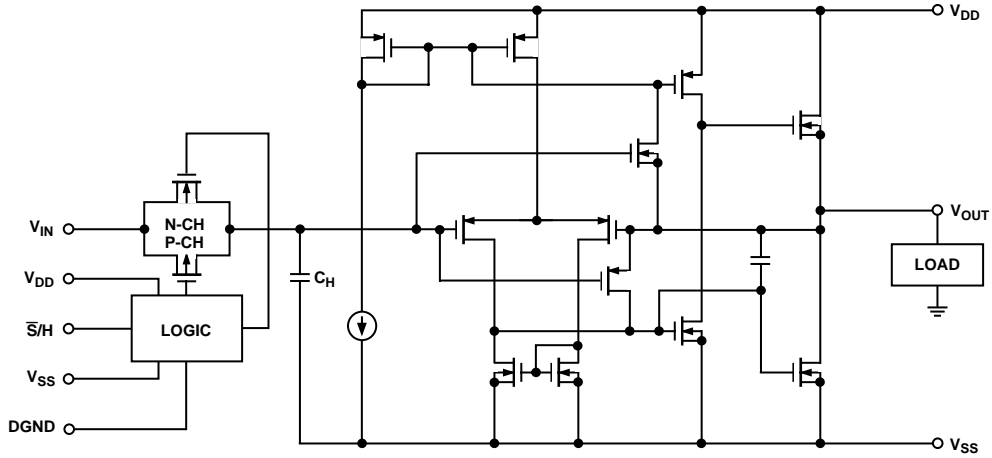

Figure 27. Simplified Schematic of One Channel

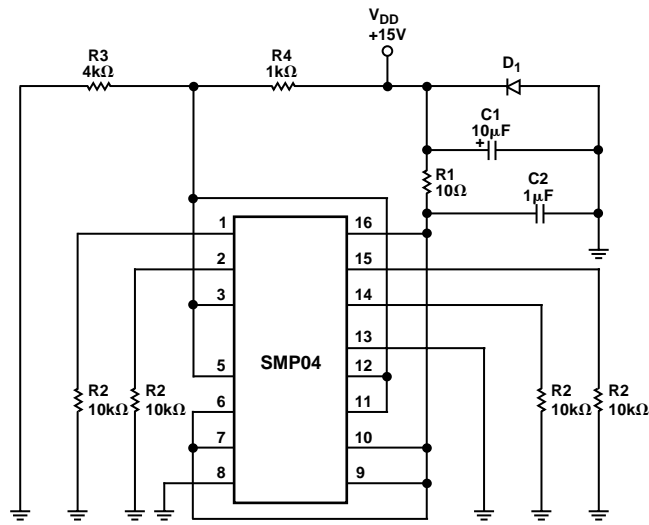
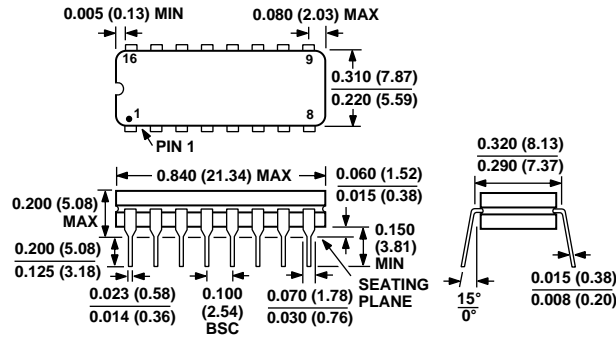

Figure 28. Burn-In Circuit

OUTLINE DIMENSIONS

Dimensions shown in inches and (mm).

16-Lead Cerdip
(Q-16)



16-Lead Plastic DIP
(N-16)

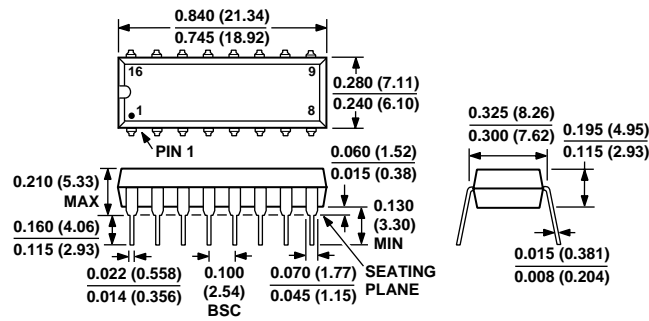

16-Lead SO
(R-16A)

