

HART-enabled vibration transmitter

PCH420V series

The PCH420V series sensors are velocity transmitters with 4-20 mA outputs and the added capability of digital communications using HART protocol. The HART functionality allows user configuration of the sensors, enables multi-drop cable installations and allows the sensor to communicate directly with a HART-enabled DCS or PLC. The benefits are a sensor that can be configured by the user for a number of different full-scale ranges and filter settings, a reduction in the required cabling, and simple connection to existing plant infrastructure. Digital sensors allow improved connectivity into plant networks, improving efficiency and simplifying decision-making about machinery health.

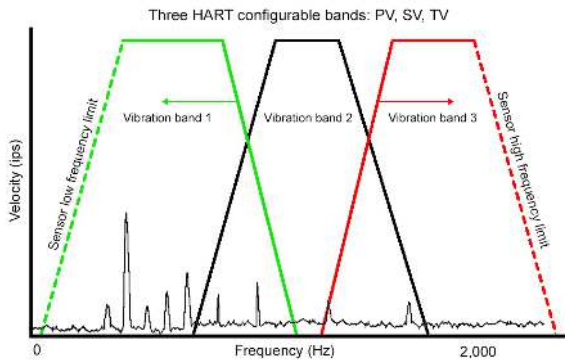

Device variables:
 PV - Vibration band 1
 SV - Vibration band 2
 TV - Vibration band 3

Model	Description
PCH420V-R6(-HZ)	4-20 mA + HART velocity sensor with 2 pin MIL-C-5015 connector
PCH420V-M12(-HZ)	4-20 mA + HART velocity sensor with 4 pin M12 connector

Note: Model numbers ending in -HZ are hazardous area certified sensors.

Certifications



-HZ models only:



Class I, Div 2
 Groups A, B, C, D
 Class I, Zone 2
 AEx/Ex nA nC IIC T4
 Tamb: -40°C to +105°C



II 3 G
 Ex nA nC IIC T4 Gc
 Ta = -40°C to +105°C



Key features

- 4-20 mA + HART 7.0 output
- Three user-configurable bands
- Single or multi-drop loop installation
- Hazardous area certified models available
- Remote configuration and diagnostics
- Connector options: 2 pin MIL-C-5015 (-R6 models) or M12 (-M12 models)
- Continuous asset monitoring
- Manufactured in an approved ISO 9001 facility

The cable installed must be suitable for the installation temperature and the voltage of any intermingled circuits. • Connected cable must be of a type suitable for Zone 2 Hazardous Locations. • The connected cable and connector must provide a minimum ingress protection level of IP54, when assessed according to EN 60079-0 and EN 60079-15. Unused connector must be fitted with an appropriately rated blanking cover. • The connection must be made in a manner that cannot be separated without the use of a tool. • Where the installation requires that the Accelerometer enclosure be grounded, this is to be done using a metal mounting stud as described in document 13327-01, 13334-01, 13335-01 or 13336-01.

Note: Due to continuous process improvement, specifications are subject to change without notice. This document is cleared for public release.

HART-enabled vibration transmitter

PCH420V series

SPECIFICATIONS

HART PARAMETERS

Full scale velocity output, 20 mA, ±10% Programmable PV band	0.5 - 5.0 in/sec, peak (12.7 - 127 mm/sec, peak)
HART analysis bands, independently programmable: PV, SV, TV	low-pass high-pass band-pass (max 2, simultaneous)
Signal detection options	RMS, peak, true peak
Minimum analysis bandwidth	10 Hz

SENSOR SPECIFICATIONS

Frequency response:	±10% ±3 dB	10 Hz - 1 kHz 3.0 Hz - 1.95 kHz
Measurement accuracy at 25°C, 100 Hz, 1 ips full scale		±5%
Power requirements, 2-wire loop power: Voltage, between pins A and B		12 - 30 VDC
Current draw		3.8 - 22 mA
Loop resistance ¹ at 24 VDC, max		600 Ω
Turn on time, 4-20 mA loop		30 seconds
Grounding		case isolated, internally shielded
Temperature range		-40° to +105° C (-40° to +221°F)
Vibration limit		500 g peak
Shock limit		5,000 g peak
Sealing		hermetic
Sensing element design		PZT, shear
Case material		316L stainless steel
Mounting		1/4-28 tapped hole
Mating connector	-M12 models	-R6 models
Recommended cabling	4 pin, M12	2 pin, MIL-C-5015
Recommended connector	J9T2A	J9T2A
	R75S	R6H series

Notes: ¹ Maximum loop resistance (R_L) can be calculated by: $R_L = \frac{V_{DC\ power} - 10.3\ V}{22.8\ mA}$
HART communication requires min. 250Ω resistance.

Accessories supplied: SF6 mounting stud; calibration data; DD (Device Description) file is available for download at buy.wilcoxon.com.

M12 connector

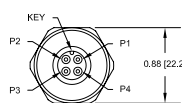

R6 connector

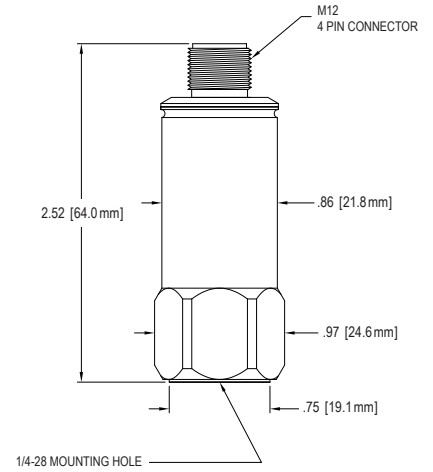
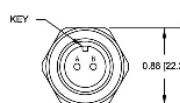

Function	Connector pin
loop positive	1
loop negative	2
N/C	3
N/C	4
ground	shell

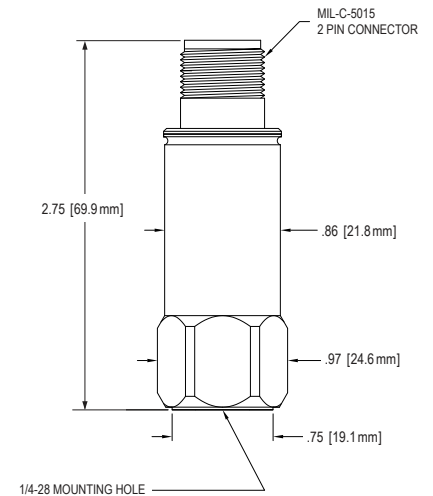

Function	Connector pin
loop positive	A
loop negative	B
ground	shell

Note: Due to continuous process improvement, specifications are subject to change without notice. This document is cleared for public release.