

BODY, REAR: ZINC ALLOY
PLATED TIN (100 MICROINCHES)

BODY, FRONT: BRASS
PLATED NICKEL (100 MICROINCHES)

CENTER CONTACT: PHOSPHOR BRONZE
PLATED GOLD (30 MICROINCHES MIN)

OUTER CASING: HIGH TEMPERATURE PLASTIC
KEYING: SEE TABLE
COLOR: SEE TABLE

INSULATOR: TEFLON

PACKAGING: TRAY

RETENTION SPECIFICATION:

THE FAKRA CONNECTOR SHROUD WILL WITHSTAND 4 PLACES
A LONGITUDINAL FORCE OF 110 N (24.75 LBS)

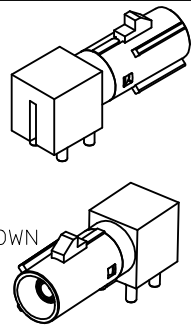
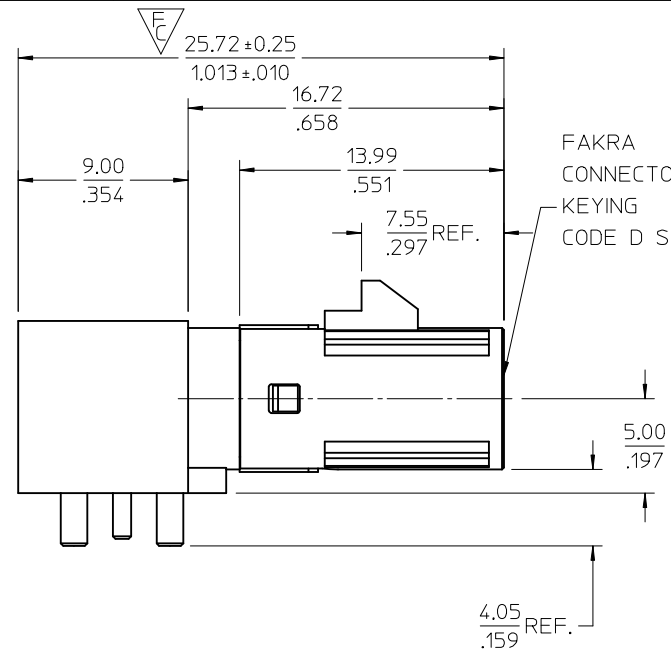
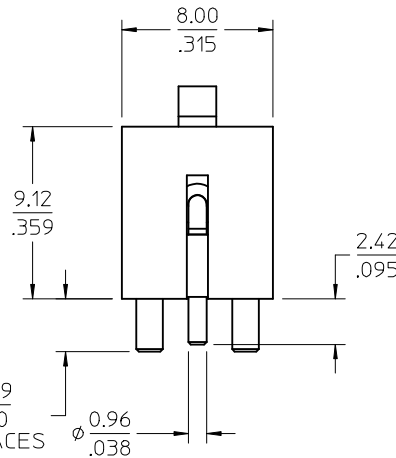

FAKRA CONNECTOR
KEYING
CODE D SHOWN

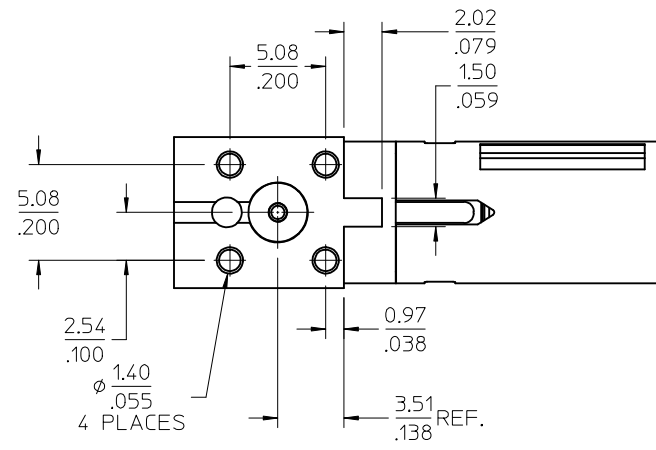
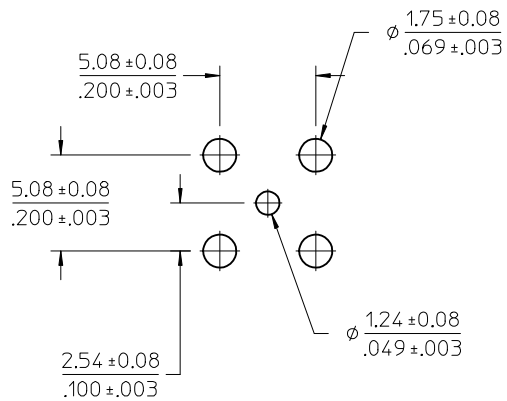

PS-89675-3310	PRODUCT SPEC.
MIL-STD-348A, FIG. 311.1	INTERFACE
SPECIFICATION	DESCRIPTION

ADDED CRITICAL DIM. PER RF16-E110 EC NO: URF2017-0019 DRW: INELIN 2016/07/11 CHKD: APPR: YCHENG 2016/07/14 B3	QUALITY SYMBOLS ∇=0 ∇=1 ∇=0	GENERAL TOLERANCES (UNLESS SPECIFIED) 4 PLACES ± --- ± --- 3 PLACES ± --- ± .010 2 PLACES ± 0.25 ± --- 1 PLACE ± --- ± --- 0 PLACE ± --- ± ---	DIMENSION STYLE MM/IN DRAWN BY DATE EL IN 2012/02/02 CHECKED BY DATE KERRIE 2012/02/02 APPROVED BY DATE MHUANG 2012/02/07	SCALE 5:1 DESIGN UNITS METRIC	THIRD ANGLE PROJECTION	
		ANGULAR ± 2 ° DRAFT WHERE APPLICABLE MUST REMAIN WITHIN DIMENSIONS	MATERIAL NO. SEE SHEET 1	TITLE SMB JACK, FAKRA,R/A, PCB 50 OHMS SMB-J/PCB molex	DOCUMENT NO. SD-73404-081	SHEET NO. 1 OF 2
		THIS DRAWING CONTAINS INFORMATION THAT IS PROPRIETARY TO MOLEX INCORPORATED AND SHOULD NOT BE USED WITHOUT WRITTEN PERMISSION				
		SIZE C				

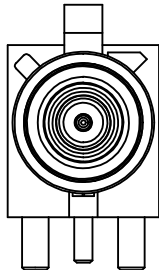

CODE A

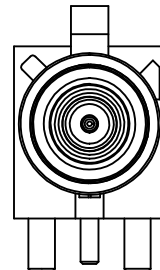

CODE B

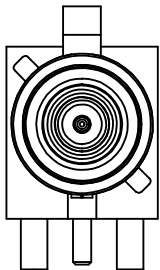

CODE C

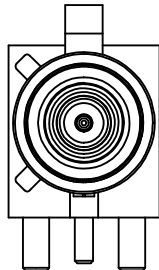

CODE D

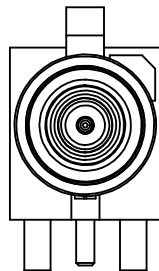

CODE E

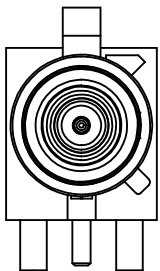

CODE F

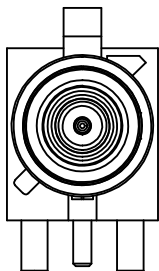

CODE G

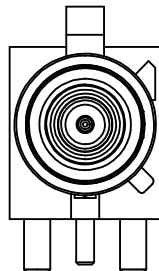

CODE H

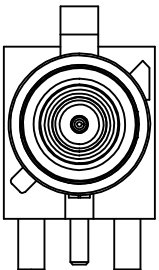

CODE I

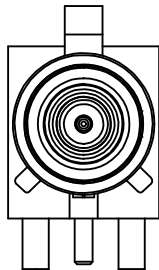

CODE K

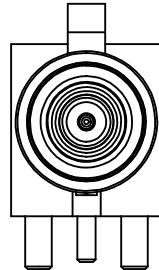

CODE Z

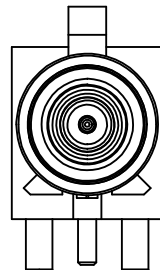

CODE L

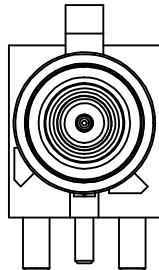

CODE M

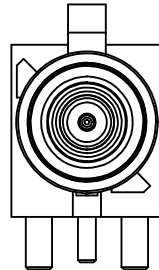

CODE N

N	PASTEL GREEN	73404-0823
M	PASTEL ORANGE	73404-0822
L	CARMINE RED	73404-0821
Z	WATER BLUE	73404-0820
K	CURRY YELLOW	73404-0819
I	BEIGE	73404-0818
H	VIOLET	73404-0817
G	GRAY	73404-0816
F	BROWN	73404-0815
E	GREEN	73404-0814
D	BORDEAUXVIOLET	73404-0813
C	BLUE	73404-0812
B	SIGNAL WHITE	73404-0811
A	BLACK	73404-0810
KEYING CODE	COLOR	PART NO.

SEE SHEET 1 EC NO: URF2017-0019 DRW:INELIN 2016/07/11 CHKD: APPR:YCHENG 2016/07/14 REV: B3	QUALITY SYMBOLS ▽=0 ▽=0 ▽=0	GENERAL TOLERANCES (UNLESS SPECIFIED) <table border="1"> <tr> <td></td> <td>mm</td> <td>INCH</td> </tr> <tr> <td>4 PLACES</td> <td>± ---</td> <td>± ---</td> </tr> <tr> <td>3 PLACES</td> <td>± ---</td> <td>± .010</td> </tr> <tr> <td>2 PLACES</td> <td>± 0.25</td> <td>± ---</td> </tr> <tr> <td>1 PLACE</td> <td>± ---</td> <td>± ---</td> </tr> <tr> <td>0 PLACE</td> <td>± ---</td> <td>± ---</td> </tr> </table>		mm	INCH	4 PLACES	± ---	± ---	3 PLACES	± ---	± .010	2 PLACES	± 0.25	± ---	1 PLACE	± ---	± ---	0 PLACE	± ---	± ---	DIMENSION STYLE MM/IN DRAWN BY EL IN DATE 2012/02/02 CHECKED BY KERRIE DATE 2012/02/02 APPROVED BY MHUANG DATE 2012/02/07	SCALE 5:1 DESIGN UNITS METRIC THIRD ANGLE PROJECTION	TITLE SMB JACK, FAKRA,R/A, PCB 50 OHMS SMB-J/PCB molex	MATERIAL NO. SEE TABLE	DOCUMENT NO. SD-73404-081	SHEET NO. 2 OF 2
		mm	INCH																							
	4 PLACES	± ---	± ---																							
	3 PLACES	± ---	± .010																							
2 PLACES	± 0.25	± ---																								
1 PLACE	± ---	± ---																								
0 PLACE	± ---	± ---																								
DRAFT WHERE APPLICABLE MUST REMAIN WITHIN DIMENSIONS		ANGULAR ± 2 °	SIZE C	THIS DRAWING CONTAINS INFORMATION THAT IS PROPRIETARY TO MOLEX INCORPORATED AND SHOULD NOT BE USED WITHOUT WRITTEN PERMISSION																						

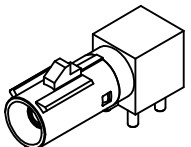

P/N 73404-081X

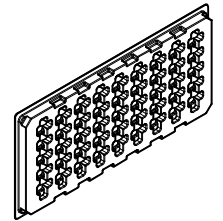

45 SET PER TRAY
TRAY P/N 89707-0253

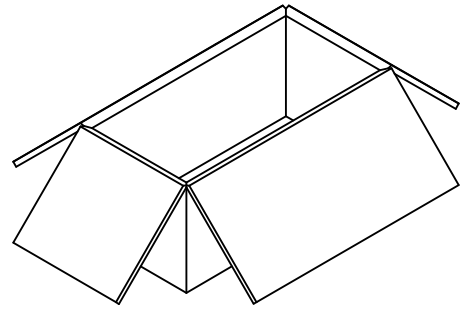

720 SET PER INNER
CARTON BOX
P/N 96707-0001

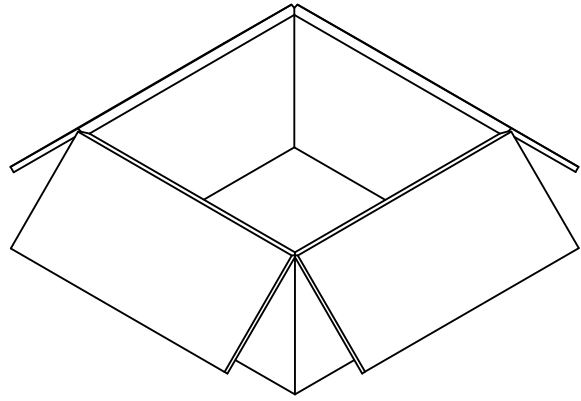

1440 SET PER OUTER
CARTON BOX
P/N 96708-0005

RF10-E059 EC NO: URF2010-0220 DRWNLIN 2009/11/03 CHKD: 2009/11/04 APPR: MHUANG 2009/11/05	QUALITY SYMBOLS =0 =0	GENERAL TOLERANCES (UNLESS SPECIFIED) <table border="1"> <tr> <th></th> <th>mm</th> <th>INCH</th> </tr> <tr> <td>4 PLACES</td> <td>± .---</td> <td>± .---</td> </tr> <tr> <td>3 PLACES</td> <td>± .---</td> <td>± .---</td> </tr> <tr> <td>2 PLACES</td> <td>± .---</td> <td>± .---</td> </tr> <tr> <td>1 PLACE</td> <td>± .---</td> <td>± .---</td> </tr> </table>		mm	INCH	4 PLACES	± .---	± .---	3 PLACES	± .---	± .---	2 PLACES	± .---	± .---	1 PLACE	± .---	± .---	DIMENSION STYLE MM/IN DRAWN BY DATE EVITA 2009/10/30 CHECKED BY DATE ALEX 2009/10/30 APPROVED BY DATE MISEN 2009/10/30 MATERIAL NO. -----	SCALE DESIGN UNITS METRIC THIRD ANGLE PROJECTION	TITLE PACKAGING FOR 73404-081
		mm	INCH																	
	4 PLACES	± .---	± .---																	
	3 PLACES	± .---	± .---																	
2 PLACES	± .---	± .---																		
1 PLACE	± .---	± .---																		
DRAFT WHERE APPLICABLE MUST REMAIN WITHIN DIMENSIONS	MOLEX INCORPORATED DOCUMENT NO. SD-73404-081-PKG	SHEET NO. 1 OF 1																		
SIZE 	THIS DRAWING CONTAINS INFORMATION THAT IS PROPRIETARY TO MOLEX INCORPORATED AND SHOULD NOT BE USED WITHOUT WRITTEN PERMISSION																			
REV A	DESCRIPTION																			