

S Series with PFC 100 Watt AC-DC Converters

The LS4000/5000 Series of AC-DC converters represents a flexible range of power supplies for use in advanced electronic systems. Features include full power factor correction, good hold-up time, high efficiency and reliability, low output voltage noise, and excellent dynamic response to load/line changes.

The converters are protected against surges and transients occurring at the source lines. Input over- and undervoltage lockout circuitry disables the outputs, when the input voltage is outside of the specified range. Input inrush current limitation is included for preventing circuit breakers and fuses from tripping at switch-on.

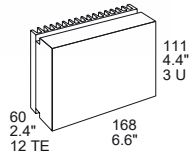

Features

- RoHS lead-free-solder and lead-solder-exempted products available
- 5 year warranty for RoHS compliant products with an extended temperature range
- Class I equipment
- Power factor >0.93, harmonics IEC/EN 61000-3-2
- Immunity according to IEC/EN 61000-4-2, -3, -4, -5, -6, -8, -9
- Compliant with EN 50155, EN 50121-4, EN 45545 (version V108 or later)
- High efficiency
- Input over- and undervoltage lockout
- Adjustable output voltage with remote on/off
- 1 or 2 outputs: ES1, no load, overload, and short-circuit proof
- Rectangular current limiting characteristic
- PCBs protected by lacquer
- Very high reliability
- Safety-approved to the latest edition of IEC/EN 62368-1 and UL/CSA 60950-1



Table of Contents

	Page
Description.....	2
Model Selection.....	2
Functional Description.....	4
Electrical Input Data.....	5
Electrical Output Data.....	8
Auxiliary Functions.....	12

Electromagnetic Compatibility (EMC).....	16
Immunity to Environmental Conditions.....	18
Mechanical Data.....	19
Safety and Installation Instructions.....	21
Description of Options.....	24
Accessories.....	30

Description

All outputs are overload, open- and short-circuit proof and protected by a built-in suppressor diode. The outputs can be inhibited by a logic signal applied to connector pin 18. If the inhibit function is not used, pin 18 must be connected with pin 14 to enable the outputs.

LED indicators display the status of the converter and allow visual monitoring of the system at any time.

Full input to output, input to case, output to case and output to output isolation is provided. The converters are designed and built according to the international safety standards IEC/EN 62368-1 3rd ed. They have been approved by the safety agencies Nemko and CSA (for USA and Canada).

The case design allows for operation at nominal load up to 71 °C in a free air ambient temperature. If forced cooling is provided, the ambient temperature may exceed 71 °C but the case temperature must remain below 95 °C under all conditions.

An internal temperature sensor generates an inhibit signal, which disables the outputs, when the case temperature T_C exceeds the limit. The outputs automatically recover, when the temperature drops below the limit.

Various options including battery chargers are available to adapt the converters to individual applications.

The converters may either be plugged into 19" rack systems according to IEC 60297-3, or be chassis mounted.

Important:

These products are intended to replace the LS1000 and LS2000 models in order to comply with IEC/EN 61000-3-2. For applications with DC input or main frequencies other than 50/60 Hz, the LS1000 and LS2000 models are still available.

Model Selection

Non-standard input/output configurations or special customer adaptations are available on request.

Table 1: Model types LS

Output 1		Output 2		Operating input voltage $V_{i\min} - V_{i\max}$ 85 – 264 VAC	Efficiency ¹ η_{\min} [%]	Options
$V_{o\text{nom}}$ [VDC]	$I_{o\text{nom}}$ [A]	$V_{o\text{nom}}$ [VDC]	$I_{o\text{nom}}$ [A]			
5.1	16	-	-	LS4001-9ERG	77	-7, -7E, P, D ² , V ² , T, B, B1, non-G
12	8	-	-	LS4301-9ERG	81	-7, -7E, P, D, T, B, B1, non-G
15	6.5	-	-	LS4501-9ERG	83	
24	4.2	-	-	LS4601-9ERG	83	
24	4	-	-	LS5320-9ERG	81	
30	3.2	-	-	LS5540-9ERG	81	
48	2	-	-	LS5660-9ERG	81	
12	4	12 ³	4	LS5320-9ERG	81	
15	3.2	15 ³	3.2	LS5540-9ERG	81	
24	2	24 ³	2	LS5660-9ERG	81	

¹ Min. efficiency at $V_{i\text{nom}}$, $I_{o\text{nom}}$ and $T_A = 25$ °C. Typical values are approximately 2% better.

² Option V for LS4000 models with 5.1 V output; excludes option D

³ Second output semi-regulated

Table 2: Battery charger models

Nom. output values		Output range ⁴ $V_{o\min} - V_{o\max}$ [VDC]	Operating input voltage $V_{i\min} - V_{i\max}$ 85 – 264 VAC	Efficiency ¹ η_{\min} [%]	Options
$V_{o\text{nom}}$ [VDC]	$I_{o\text{nom}}$ [A]				
12.84	7	12.62 – 14.12	LS4740-9ERG	81	-7, -7E, D, T, B, B1, non-G
25.68 ²	3.4	25.25 – 28.25	LS5740-9ERG	81	-7, -7E, D, T, B, B1, non-G
51.36 ³	1.7	50.50 – 56.50	LS5740-9ERG	81	

¹ Min. efficiency at $V_{i\text{nom}}$, $I_{o\text{nom}}$ and $T_A = 25$ °C. Typical values are approximately 2% better.

² Both outputs connected in parallel

³ Both outputs connected in series

 NFND: Not for new designs.

 Preferred for new designs

Part Number Description

LS 5 5 40 -9 E R D3 T B1 G

Operating input voltage V_i : 85 – 264 VAC	LS
Number of outputs (4 = single, 5 = double)	4, 5
Single output models:	
Nominal voltage output 1 $V_{o1\text{ nom}}$ (main output)	
5.1 V	0, 1, 2
12 V	3
15 V	4, 5
24 V	6
Other voltages ¹	7, 8
Other specifications (single output models) ¹	01 - 99
Double output models:	
Nominal voltage output 1 and 2	
12 V, 12 V	20
15 V, 15 V	40
24 V, 24 V	60
Other specifications or additional features ¹	21 – 99
Operational ambient temperature range T_A :	
–25 to 71 °C	-7
–40 to 71 °C	-9
Other ¹	-0, -5, -6
Auxiliary functions and options:	
Inrush current limitation	E ²
Output voltage control input	R ³
Potentiometer (output voltage adjustment)	P ³
Undervoltage monitor (D0 – DD, to be specified)	D ⁴
ACFAIL signal (V2, V3, to be specified)	V ³
Current share	T
Cooling plate standard case	B or B1
Cooling plate for long case 220 mm ¹	B2
RoHS-compliant for all 6 substances ⁶	G

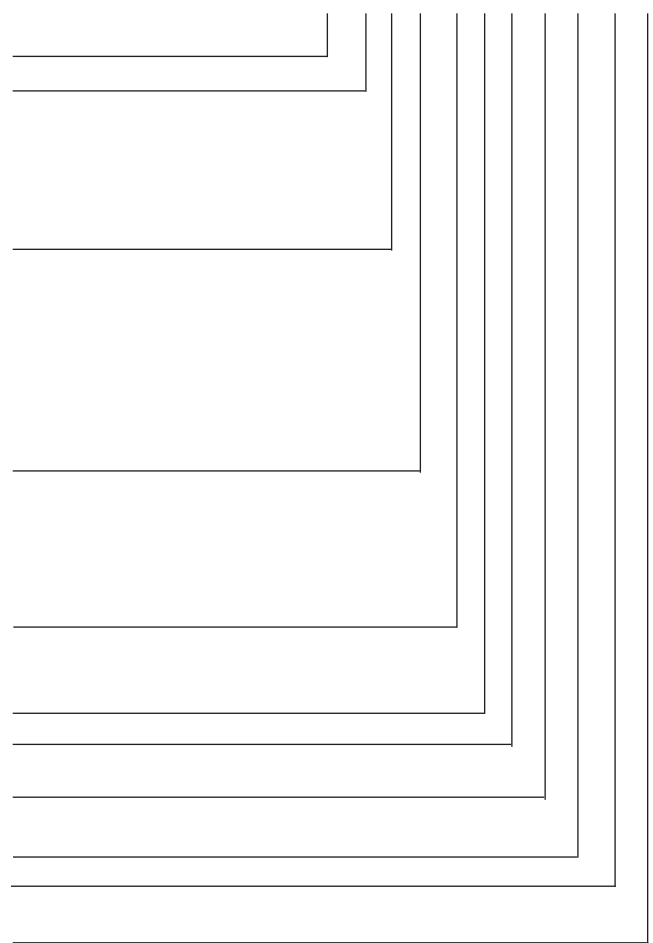

¹ Customer-specific models
² Option E mandatory for all -9 models
³ Feature R excludes option P and vice versa. Option P is not available for battery charger models.
⁴ Option D excludes option V and vice versa; option V is available for 5.1 V models only.

Note: The sequence of options must follow the order above. This part number description is descriptive only; it is not intended for creating part numbers.

 NFND: Not for new designs. Preferred for new designs

Example: LS5540-9ERD3TB1G: Power factor corrected AC-DC converter, operating input voltage range 85 – 264 VAC, 2 electrically isolated outputs, each providing 15 V, 3.2 A, equipped with inrush current limiter, R-input to adjust the output voltages, undervoltage monitor D3, current share feature, a cooling plate B1, RoHS-compliant.

Product Marking

Basic type designation, applicable approval marks, CE mark, warnings, pin designation, patents and company logo, identification of LEDs, test sockets, and potentiometer.

Specific type designation, input voltage range, nominal output voltages and currents, degree of protection, batch no., serial no., data code including production site, modification status, and date of production.

Functional Description

The input voltage is fed via an input fuse, an input filter, a rectifier, and an inrush current limiter to a boost converter. This step-up converter provides a sinusoidal input current (IEC/EN 61000-3-2, class D equipment) and charges the bulk capacitor C_b to approx. 370 VDC. This capacitor sources a single transistor forward converter and provides the power during the hold-up time.

Each output is powered by a separate secondary winding of the main transformer. The resultant voltages are rectified and their ripple smoothed by a power choke and an output filter. The control logic senses the main output voltage V_{o1} and generates, with respect to the maximum admissible output currents, the control signal for the switching transistor of the forward converter.

The second output of double output models is tracking to the main output, but has its own current limiting circuit. If the main output voltage drops due to current limitation, the second output voltage will fall as well and vice versa.

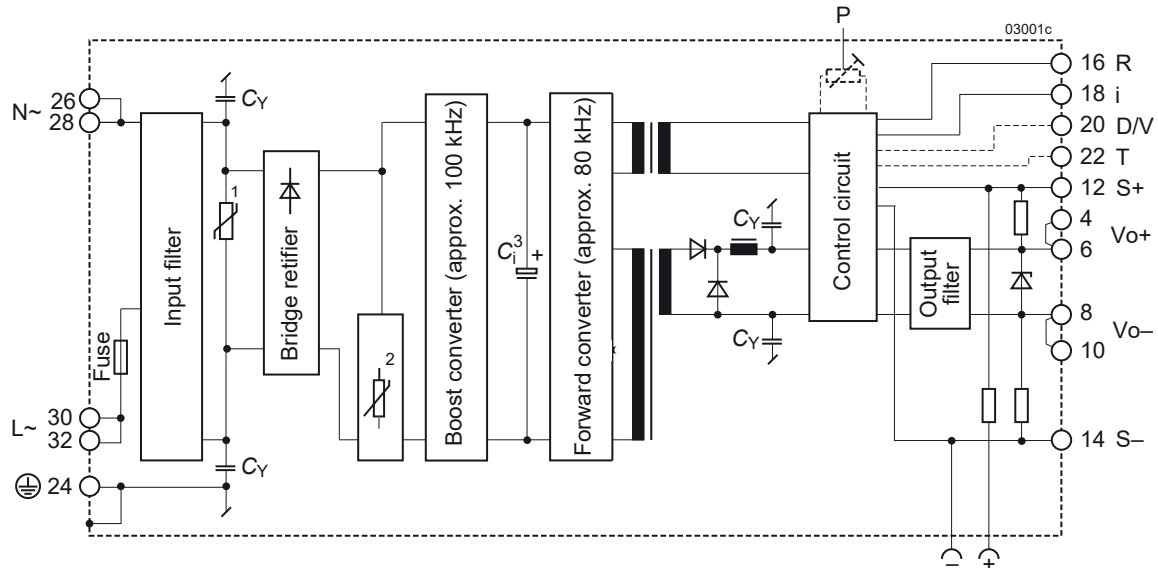

Fig. 1
Block diagram of single-output converters

- 1 Transient suppressor (VDR)
- 2 Inrush current limiter (NTC, only models with $T_{Amin} = -25^\circ\text{C}$) or option E
- 3 Bulk capacitor C_b ; bulk voltage approx. 370 V

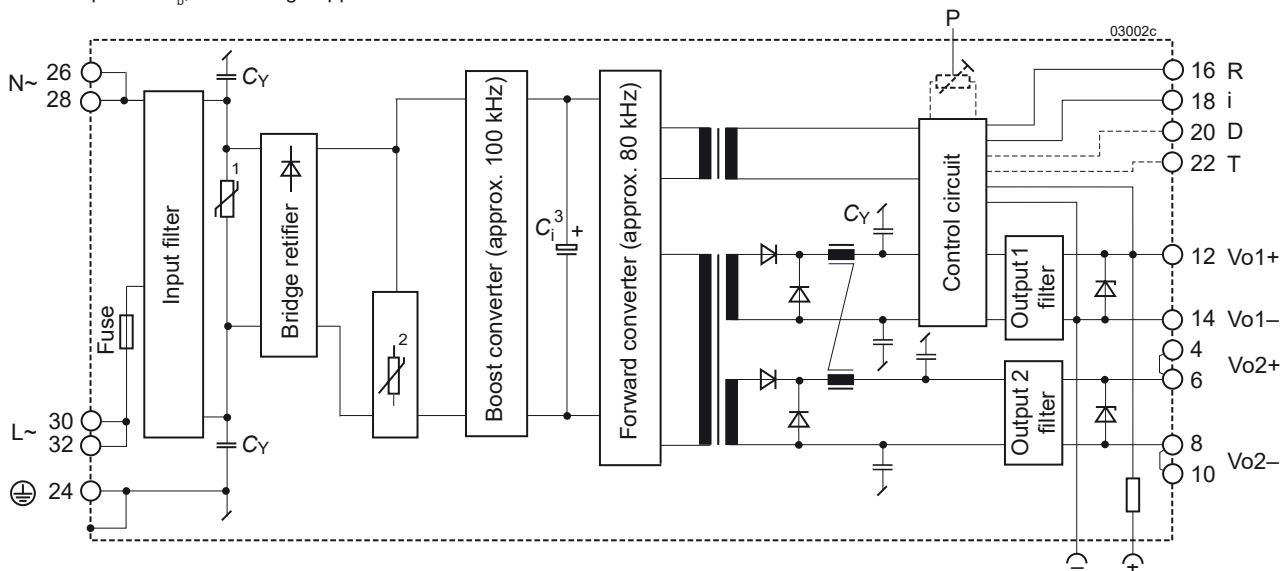

Fig. 2
Block diagram of double-output models

- 1 Transient suppressor (VDR)
- 2 Inrush current limiter (NTC, only models with $T_{Amin} = -25^\circ\text{C}$) or option E
- 3 Bulk capacitor C_b ; bulk voltage approx. 370 V

Electrical Input Data

General Conditions:

- $T_A = 25\text{ °C}$, unless T_C is specified.
- Pin 18 connected to pin 14, R input not connected, V_o adjusted to $V_{o,nom}$ (option P)
- Sense line pins S+ and S– connected to V_{o+} and V_{o-} , respectively.

Table 3: Input data

Model			LS			Unit
Characteristics		Conditions	min	typ	max	
V_i	Rated input voltage range	$I_o = 0 - I_{o,nom}$	100		240	VAC ¹
$V_{i,op}$	Operating input voltage range	$T_{C,min}$ to $T_{C,max}$	85		264	
$V_{i,nom}$	Nominal input voltage	50 – 60 Hz		230		
I_i	Input current	$V_{i,nom}, I_{o,nom}$ ²		0.55		A
P_{i0}	No-load input power	$V_{i,min} - V_{i,max}, I_o = 0$		7.5	9	W
$P_{i,inh}$	Idle input power	Converter inhibited		2	3	
R_i	Input resistance		480			mΩ
R_{NTC}	NTC resistance (see Fig.3) ³	Converter not operating	3200	4000		
C_b	Input capacitance		80	100	120	μF
$V_{i,RFI}$	Conducted input RFI	EN 55011/55022		B		
	Radiated input RFI	$V_{i,nom}, I_{o,nom}$		B		
$V_{i,abs}$	Input voltage limits without damage				283	VAC
			–400		400	VDC ⁴

¹ Nominal frequency range: 50 – 60 Hz, operating frequency range 47 – 63 Hz

² With double-output models, both outputs loaded with $I_{o,nom}$

³ Valid for -7 versions without option E. This is the NTC resistance value at 25 °C and applies to cold converters. Subsequent switch-on/off cycles increase the inrush current peak value.

⁴ Operation with DC input voltage is not specified and not recommended.

Input Transient Protection

A VDR together with the input fuse and a symmetrical input filter form an effective protection against high input transient voltages.

Input Fuse

A fuse mounted inside the converter in series to the phase line protects against severe defects. A second fuse in the neutral line may be necessary in certain applications; see *Installation Instructions*.

Fuse specification:

Slow-blow, 4 A, 250 V, 5 × 20 mm.

Input Under-/Overvoltage Lockout

If the input voltage remains below approx. 65 VAC or exceeds $V_{i,abs}$, an internally generated inhibit signal disables the output(s). Do not check the overvoltage lockout function!

If V_i is below $V_{i,min}$, but above the undervoltage lockout level, the output voltage may be below the value specified in the tables *Electrical Output Data*.

Inrush Current Limitation

The -7 models without option E incorporate an NTC resistor in the input circuitry, which at initial turn-on reduces the peak inrush current value by a factor of 5 to 10 to protect connectors and switching devices from damage. Subsequent switch-on cycles within short periods will cause an increase of the peak inrush current value due to the warming-up of the NTC resistor.

The inrush current peak value (initial switch-on cycle) can be determined by following calculation:

$$I_{inr,p} = \frac{V_i \cdot \sqrt{2}}{(R_{s,ext} + R_i + R_{NTC})}$$

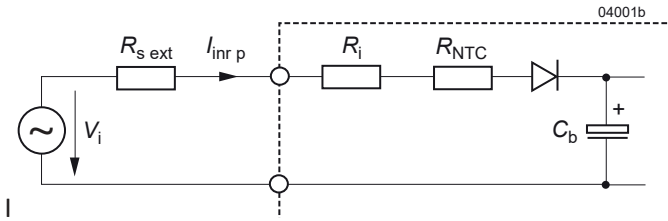

Fig. 3
Equivalent circuit diagram for input impedance.

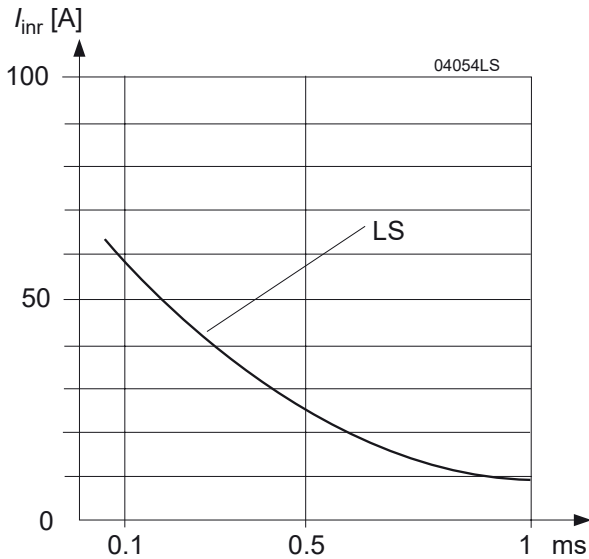

Fig. 4
Theoretical input inrush current versus time at $V_i = 255 \text{ V}$ and 115 V , $R_{\text{ext}} = 0$ for models without option E

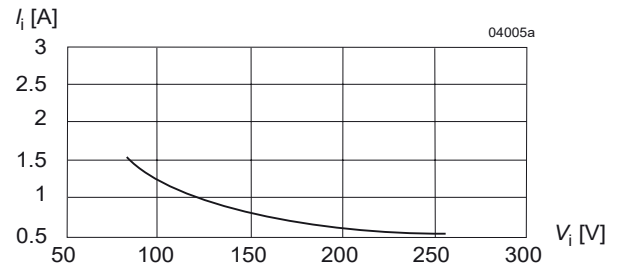

Fig. 5
Input current versus input voltage at $I_{o \text{ nom}}$

Switching Frequency

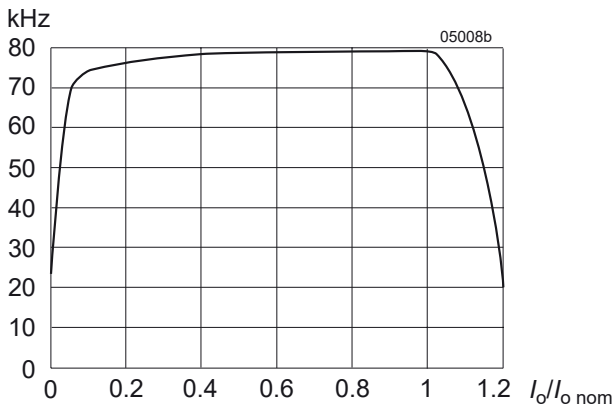

Fig. 6
Typ switching frequency versus load. The boost converter at the input stage operates with a constant switching frequency of 100 kHz.

Power Factor and Harmonics

Power factor correction is achieved by controlling the input current waveform synchronously with the input voltage waveform. The power factor control is active under all operating conditions.

The harmonic distortion is well below the limits specified in IEC/EN 61000-3-2, class D; see fig. below:

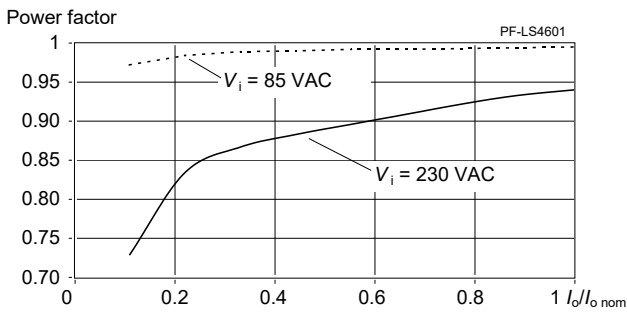

Fig. 7
Power factor versus output current (LS4601-7R)

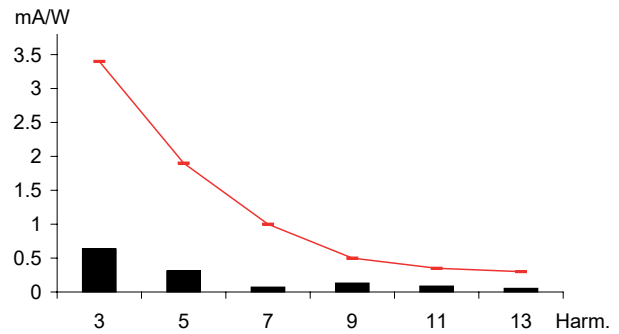

Fig. 8
Harmonic currents at the input: $V_i=230$ VAC, $I_o=I_{o,nom}$ (LS4601).

Hold-up Time

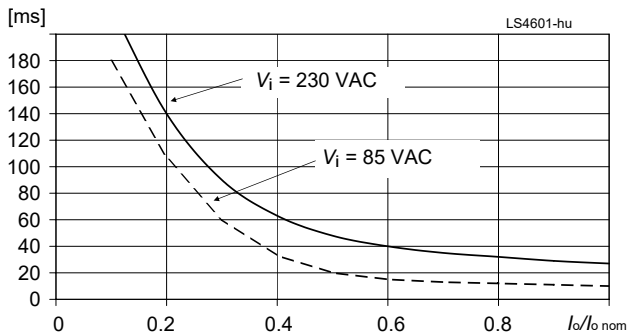

Fig. 9
Hold-up time versus output power (LS4601-7R)

Efficiency

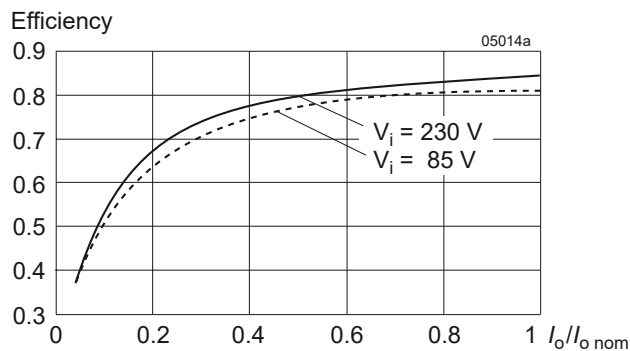

Fig. 10
Efficiency versus output power.

Electrical Output Data

General Conditions:

- $T_A = 25\text{ }^\circ\text{C}$, unless T_C is specified.
- Pin 18 (i) connected to pin 14 (S– or Vo1–), R input not connected, V_o adjusted to $V_{o,nom}$ (option P),
- Sense line pins 12 (S+) and 14 (S–) connected to pins 4 (Vo1+) and 8 (Vo1–), respectively.

Table 4a: Output data of single-output models

Model		LS4001			LS4301 / LS4740 ⁵			LS4501			LS4601			Unit		
Output		5.1 V			12 V ⁵			15 V			24 V					
Characteristics		Conditions		min	typ	max	min	typ	max	min	typ	max	min	typ	max	
V_o	Output voltage	$V_{i,nom}, I_{o,nom}$		5.07		5.13	11.93 ⁵		12.07 ⁵	14.91		15.09	23.86		24.14	V
$V_{o,BR}$	Output protection (suppressor diode) ⁶			7.9			15.2/17 ⁵			19.6			28.5			
$I_{o,nom}$	Output current nom. ¹	$V_{i,min} - V_{i,max}$ $T_{C,min} - T_{C,max}$			16			8/7 ⁵		6.5				4.2		A
$I_{o,L}$	Output current limit ¹	$V_{i,min} - V_{i,max}$		16.2			8.2/8 ⁵			6.7			4.4			
V_o	Output noise ³	Low frequency	$V_{i,nom}, I_{o,nom}$ BW = 20 MHz			2		2		2		2		2		mV _{pp}
		Switching frequ.				10		5		5		5				
		Total incl. spikes				50		40		40		40				
$\Delta V_{o,u}$	Static line regulation with respect to $V_{i,nom}$	$V_{i,min} - V_{i,max}$ $I_{o,nom}$				±5			±12			±15		±24	mV	
$\Delta V_{o,l}$	Static load regulation	$V_{i,nom}$ $(0.1 - 1)I_{o,nom}$				-20			-25			-30		-40		
$V_{o,d}$	Dynamic load regulation ²	Voltage deviation ²	$V_{i,nom}$ $I_{o,nom} \leftrightarrow 0.5 I_{o,nom}$			±100		±100		±100		±100		±100	ms	
t_d		Recovery time ²				0.3		0.4		0.4		0.3				
$\alpha_{v,o}$	Temperature coefficient of output voltage ⁴	$I_{o,nom}$ $T_{C,min} - T_{C,max}$			±0.02		±0.02		±0.02		±0.02		±0.02		%/K	

- ¹ If the output voltages are increased above $V_{o,nom}$ through R-input control, option P setting, remote sensing or option T, the output currents should be reduced accordingly so that $P_{o,nom}$ is not exceeded.
- ² See *Dynamic load regulation (fig. 13)*
- ³ Measured according to IEC/EN 61204 with a probe according to annex A
- ⁴ For battery charger applications, a defined negative temperature coefficient can be provided by using a temperature sensor (see *Accessories*), but we recommend choosing special battery charger models.
- ⁵ Especially designed for battery charging using the temperature sensor (see *Accessories*). V_o is set to 12.84 V ±1% (R-input open).
- ⁶ Breakdown voltage of the incorporated suppressor diode (1 mA; 10 mA for 5 V output). Exceeding $V_{o,BR}$ is dangerous for the suppressor diode.

Table 4b: Output data of double-output models

Model (Nom. output voltage)			LS5320 (2 x 12 V)						LS5540 (2 x 15 V)						Unit
Characteristics		Conditions	Output 1			Output 2			Output 1			Output 2			
			min	typ	max	min	typ	max	min	typ	max	min	typ	max	
V_o	Output voltage		$V_{i\text{nom}}^1 I_{o\text{nom}}^1$			11.93	12.7	11.82	12.18	14.91	15.09	14.78	15.22	V	
V_{oP}	Output protection (suppressor diode) ⁸					15.2		15.2		19.6		19.6			
$I_{o\text{nom}}$	Output current nom. ²		$\frac{V_{i\text{min}} - V_{i\text{max}}}{T_{C\text{min}} - T_{C\text{max}}}$			4			4			3.2			A
I_{oL}	Output current limit ⁶		$V_{i\text{min}} - V_{i\text{max}}$			4.2			4.2			3.4			
uV_o	Output noise ³	Low frequency	$V_{i\text{nom}}^1 I_{o\text{nom}}$			3			3			3			mV _{pp}
		Switching frequ.	BW = 20 MHz			12			12			10			
		Total incl. spikes				40			40			50			
ΔV_{oU}	Static line regulation with respect to $V_{i\text{nom}}$		$\frac{V_{i\text{min}} - V_{i\text{max}}}{I_{o\text{nom}}}$			±12			6			±15			mV
ΔV_{oI}	Static load regulation		$\frac{V_{i\text{nom}}}{(0.1 - 1)I_{o\text{nom}}}$			-40			6			-50			
V_{oD}	Dynamic load regulation ³	Voltage deviation ⁴	$V_{i\text{nom}}$			±100			±150			±100			ms
t_d		Recovery time ⁴	$I_{o1\text{nom}} \leftrightarrow 0.5 I_{o1\text{nom}}$ $0.5 I_{o2\text{nom}}$			0.3			0.4			0.4			
α_{v_o}	Temperature coefficient of output voltage ⁵		$\frac{I_{o\text{nom}}}{T_{C\text{min}} - T_{C\text{max}}}$			±0.02			±0.02			±0.02			%/K

Table 4c: Output data of double-output models

Model (Nom. output voltage)			LS5660 / 5740 (2 x 24 V / 2 x 25.68 V) ⁷						Unit			
Characteristics		Conditions	Output 1			Output 2						
			min	typ	max	min	typ	max				
V_o	Output voltage		$V_{i\text{nom}}^1 I_{o\text{nom}}^1$			23.86 ⁷	24.14 ⁷	23.64 ⁷	24.36 ⁷	V		
V_{oP}	Output protection (suppressor diode) ⁸					28.5/34 ⁷			28.5/34 ⁷			
$I_{o\text{nom}}$	Output current nom. ²		$\frac{V_{i\text{min}} - V_{i\text{max}}}{T_{C\text{min}} - T_{C\text{max}}}$			2/1.7 ⁷			2/1.7 ⁷			A
I_{oL}	Output current limit ⁶		$V_{i\text{min}} - V_{i\text{max}}$			2.1/2 ⁷			2.1/2 ⁷			
uV_o	Output noise ³	Low frequency	$V_{i\text{nom}}^1 I_{o\text{nom}}$			3			3			mV _{pp}
		Switching frequ.	BW = 20 MHz			5			5			
		Total incl. spikes				40			40			
ΔV_{oU}	Static line regulation with respect to $V_{i\text{nom}}$ ³		$\frac{V_{i\text{min}} - V_{i\text{max}}}{I_{o\text{nom}}}$			±30			6			mV
ΔV_{oI}	Static load regulation		$\frac{V_{i\text{nom}}}{(0.1 - 1)I_{o\text{nom}}}$			-40			6			
V_{oD}	Dynamic load regulation ³	Voltage deviation ⁴	$V_{i\text{nom}}$			±100			±150			ms
t_d		Recovery time ⁴	$I_{o1\text{nom}} \leftrightarrow 0.5 I_{o1\text{nom}}$ $0.5 I_{o2\text{nom}}$			0.3			0.3			
α_{v_o}	Temperature coefficient of output voltage ⁵		$\frac{I_{o\text{nom}}}{T_{C\text{min}} - T_{C\text{max}}}$			±0.02			±0.02			%/K

¹ Same conditions for both outputs

² If the output voltages are increased above $V_{o\text{nom}}$ via R-input control, option P setting, remote sensing or option T, the output currents should be reduced accordingly so that $P_{o\text{nom}}$ is not exceeded.

³ Measured according to IEC/EN 61204 with a probe annex A

⁴ See *Dynamic load regulation (fig. 13)*

⁵ For battery charger applications a defined negative temperature coefficient can be provided by using a temperature sensor, see *Accessories*.

⁶ See *Output Voltage Regulation of Double-Output Models*

⁷ Especially designed for battery charging using the battery temperature sensor (see *Accessories*). V_{o1} is set to 25.68 V ±1% (R-input open).

⁸ Breakdown voltage of the incorporated suppressor diodes (1 mA). Exceeding V_{oBR} is dangerous for the suppressor diodes.

Thermal Considerations

If a converter is located in free, quasi-stationary air (convection cooling) at the indicated maximum ambient temperature $T_{A \max}$ (see table *Temperature specifications*) and is operated at its nominal input voltage and output power, the temperature measured at the *Measuring point of case temperature* T_C (see *Mechanical Data*) will approach the indicated value $T_{C \max}$ after the warm-up phase. However, the relationship between T_A and T_C depends heavily on the conditions of operation and integration into a system. The thermal conditions are influenced by input voltage, output current, airflow, and temperature of surrounding components and surfaces. $T_{A \max}$ is therefore, contrary to $T_{C \max}$, an indicative value only.

Caution: The installer must ensure that under all operating conditions T_C remains within the limits stated in the table *Temperature specifications*.

Notes: Sufficient forced cooling or an additional heat sink allows T_A to be higher than 71 °C (e.g. 85 °C), if $T_{C \max}$ is not exceeded.

For -7 or -9 models at an ambient temperature T_A of 85 °C with only convection cooling, the maximum permissible current for each output is approx. 40% of its nominal value as per the figure below.

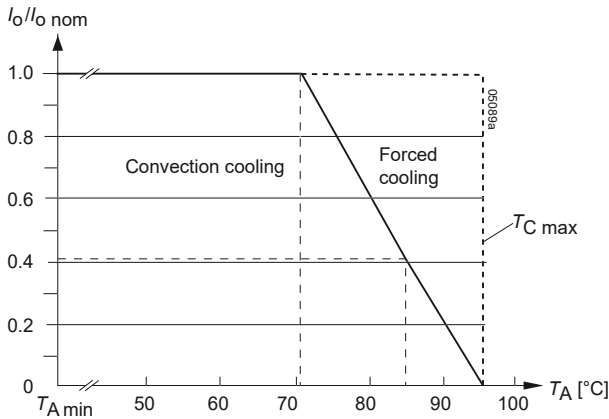

Fig. 11
Output current derating versus temperature for -7 and -9 models.

Thermal Protection

A temperature sensor generates an internal inhibit signal, which disables the outputs if the case temperature exceeds $T_{C \max}$. The outputs are automatically re-enabled, when the temperature drops below this limit.

It is recommended that continuous operation under simultaneous extreme worst-case conditions of the following three parameters be avoided: Minimum input voltage, maximum output power, and maximum temperature.

Output Protection

Each output is protected by a suppressor diode against overvoltage, which could occur due to a failure of the control circuit. In such a case, the suppressor diode becomes a short circuit. The suppressor diodes may smooth short overvoltages resulting from dynamic load changes, but they are not designed to withstand externally applied overvoltages.

A short circuit at any of the two outputs will cause a shut-down of the other output. A red LED indicates an overload condition.

Note: V_{oBR} is specified in *Electrical Output Data*. If this voltage is exceeded, the suppressor diode generates losses and may become a short circuit.

Parallel or Series Connection of Converters

Single- or double-output models with equal output voltage can be connected in parallel using option T (current sharing). If the T pins are interconnected, all converters share the output current equally.

Single-output models and/or main and second outputs of double-output models can be connected in series with any other (similar) output.

Notes:

- Parallel connection of double-output models should always include both, main and second output to maintain good regulation.
- Not more than 5 converters should be connected in parallel.
- Series connection of second outputs without involving their main outputs should be avoided, as regulation may be poor.
- The maximum output current is limited by the output with the lowest current limitation, if several outputs are connected in series.

Output Voltage Regulation

The following figures apply to single-output or double-output models with parallel-connected outputs.

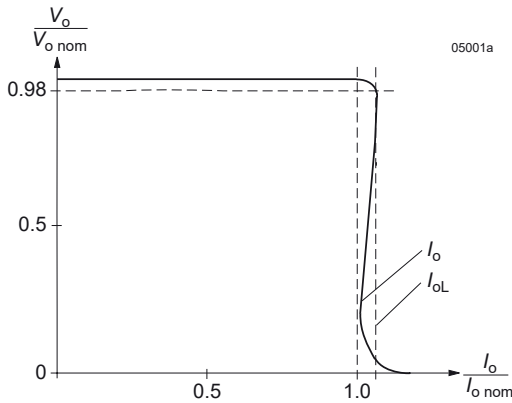

Fig. 12
Typ output characteristic V_{o1} versus I_{o1} .

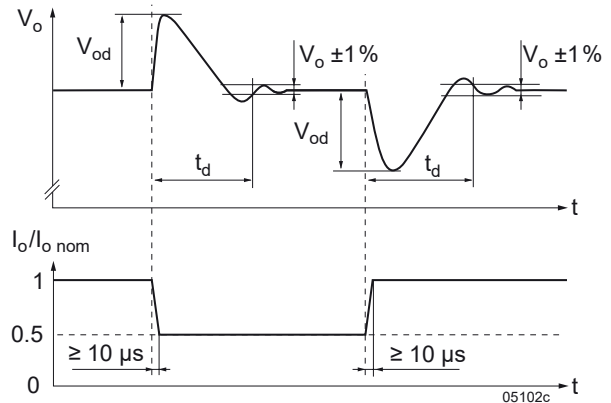

Fig. 13
Typical dynamic load regulation of V_o .

Output Regulation of Double-Output Models

Output 1 is under normal conditions regulated to $V_{o,nom}$, independent of the output currents.

V_{o2} depends upon the load distribution. If both outputs are loaded with more than 10% of $I_{o,nom}$, the deviation of V_{o2} remains within $\pm 5\%$ of the value of V_{o1} . The following 3 figures show the regulation with varying load distribution.

Two outputs of an LS5000 model connected in parallel will behave like the output of an LS4000 model.

Note: If output 2 is not used, we recommend connecting it in parallel with output 1. This ensures good regulation and efficiency.

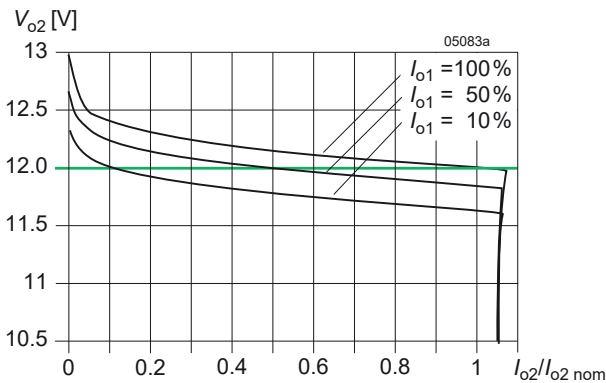

Fig. 14
LS5320: ΔV_{o2} versus I_{o2} with various I_{o1} (typ).

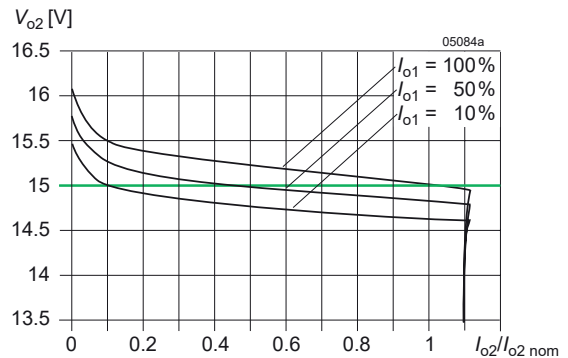

Fig. 15
LS5540: V_{o2} versus I_{o2} with various I_{o1} (typ).

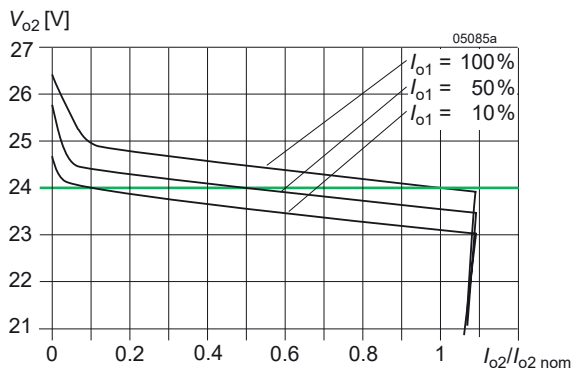

Fig. 16
LS5660: V_{o2} versus I_{o2} with various I_{o1} (typ).

Auxiliary Functions

Inhibit for Remote On/Off

The outputs may be enabled or disabled by means of a logic signal (TTL, CMOS, etc.) applied between the inhibit input i (pin 18) and pin 14 (S- or Vo1-). In systems with several converters, this feature can be used to control the activation sequence of the converters. If the inhibit function is not required, connect the inhibit pin 18 to pin 14.

Note: If pin 18 is not connected, the output is disabled.

Table 5: Inhibit characteristics

Characteristics		Conditions	min	typ	max	Unit
V_{inh}	Inhibit voltage	$V_o = \text{on}$	-50		0.8	V
		$V_o = \text{off}$		2.4	50	
I_{inh}	Inhibit current	$V_{inh} = 0$			-400	μA
t_r	Rise time			30		ms
t_f	Fall time	Depending on I_o				

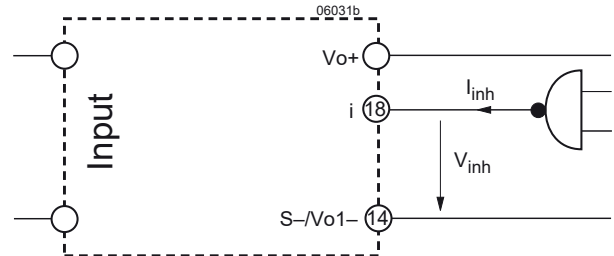

Fig. 17
Definition of V_{inh} and I_{inh} .

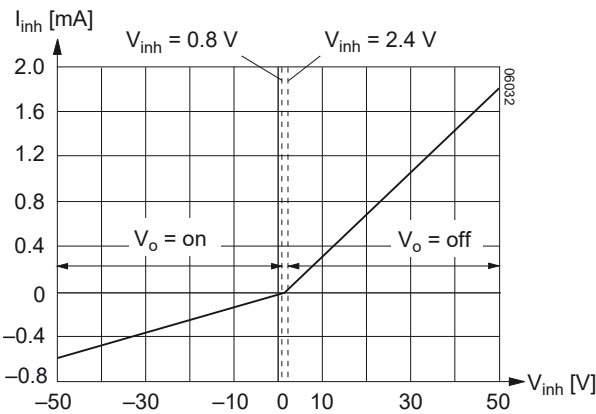

Fig. 18
Typical inhibit current I_{inh} versus inhibit voltage V_{inh}

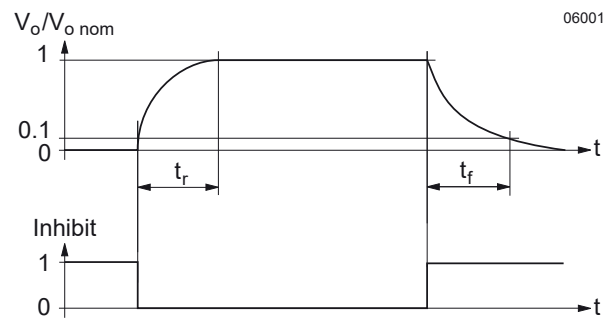

Fig. 19
Output response as a function of inhibit control

Sense Lines (Single-Output Models)

Important: Sense lines must always be connected! Incorrectly connected sense lines may activate the overvoltage protection resulting in a permanent short-circuit of the output.

This feature allows for compensation of voltage drops across the connector contacts and if necessary, across the load lines. We recommend connecting the sense lines directly at the female connector.

To ensure correct operation, both sense lines (S+, S-) should be connected to their respective power outputs (Vo+ and Vo-). The voltage difference between any sense line and its respective power output (as measured on the connector) should not exceed the following values:

Table 6: Maximum voltage compensation allowed using sense lines

Output voltage	Total voltage difference between sense lines and their respective outputs	Voltage difference between Vo- and S-
5.1 V	< 0.5 V	< 0.25 V
12 V, 15 V, 24 V	< 1.0 V	< 0.25 V

Note: If the output voltages are increased above $V_{o,nom}$ via R-input control, option P setting, remote sensing, or option T, the output currents must be reduced accordingly, so that $P_{o,nom}$ is not exceeded.

Programmable Output Voltage (R-Function)

As a standard feature, the converters offer an adjustable output voltage, identified by letter R in the type designation. The control input R (pin 16) accepts either a control voltage V_{ext} or a resistor R_{ext} to adjust the desired output voltage. When R is not connected, the output voltage is set to $V_{o, nom}$.

a) Adjustment by means of an external control voltage V_{ext} between pin 16 (R) and pin 14:

The control voltage range is 0 – 2.75 V and allows an output voltage adjustment in the range of approximately 0 – 110% $V_{o, nom}$.

$$V_{ext} \approx \frac{V_o}{V_{o, nom}} \cdot 2.5 \text{ V}$$

b) Adjustment by means of an external resistor:

Depending upon the value of the required output voltage the resistor shall be connected

either: Between pin 16 and pin 14 ($V_o < V_{o, nom}$) to achieve an output voltage adjustment range of approx. 0 – 100% $V_{o, nom}$.

or: Between pin 16 and pin 12 ($V_o > V_{o, nom}$) to achieve an output voltage adjustment range of approx. 100 – 110% $V_{o, nom}$.

Warning:

- V_{ext} shall never exceed 2.75 V.
- The value of R'_{ext} shall never be less than the lowest value as indicated in table R'_{ext} (for $V_o > V_{o, nom}$) to prevent the converter from damage!

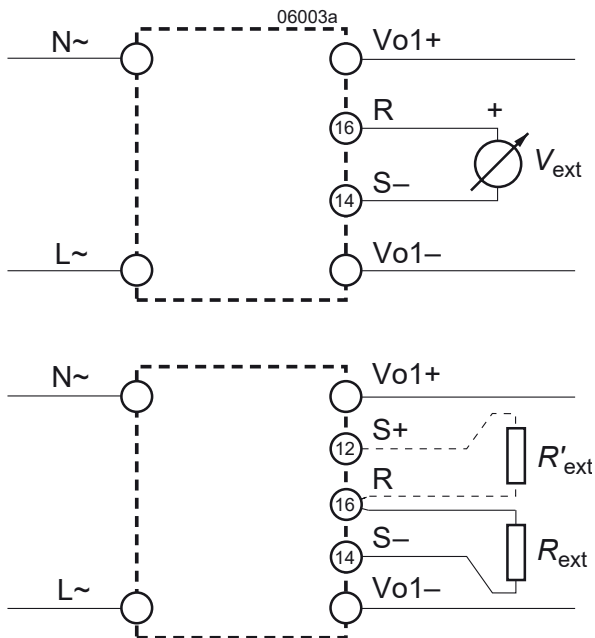

Fig. 20
Output voltage control for single-output models

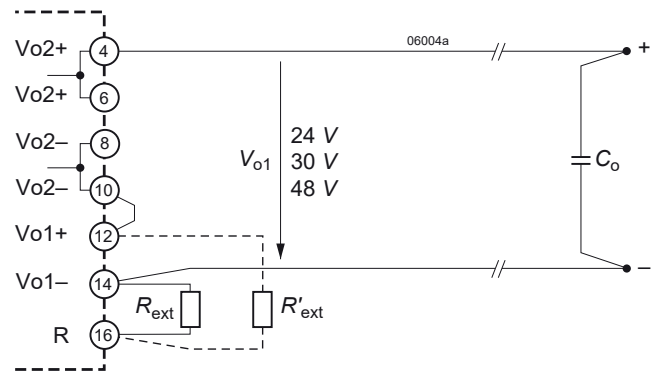

Fig. 21
Double-output models:
Wiring of the R-input for output voltages 24 V, 30 V, or 48 V with both outputs in series. A ceramic capacitor (C_o) across the load reduces ripple and spikes.

Notes:

- The R-Function excludes option P (output voltage adjustment by potentiometer).
If the output voltages are increased above $V_{o, nom}$ via R-input control, option P setting, remote sensing or option T, the output current(s) should be reduced accordingly so that $P_{o, nom}$ is not exceeded.
- With double-output models the second output follows the value of the controlled main output.
- In case of parallel connection the output voltages should be individually set within a tolerance of 1 – 2%.

Table 7a: R_{ext} for $V_o < V_{o,nom}$; approximate values ($V_{i,nom}$, $I_{o,nom}$, series E 96 resistors); R'_{ext} = not fitted

$V_{o,nom} = 5.1 V$		$V_{o,nom} = 12 V$			$V_{o,nom} = 15 V$			$V_{o,nom} = 24 V$		
$V_o [V]$	$R_{ext} [k\Omega]$	$V_o [V]^1$		$R_{ext} [k\Omega]$	$V_o [V]^1$		$R_{ext} [k\Omega]$	$V_o [V]^1$		$R_{ext} [k\Omega]$
0.5	0.432	2	4	0.806	2	4	0.619	4	8	0.81
1.0	0.976	3	6	1.33	4	8	1.47	6	12	1.33
1.5	1.65	4	8	2	6	12	2.67	8	16	2.0
2.0	2.61	5	10	2.87	8	16	4.53	10	20	2.87
2.5	3.83	6	12	4.02	9	18	6.04	12	24	4.02
3.0	5.76	7	14	5.62	10	20	8.06	14	28	5.62
3.5	8.66	8	16	8.06	11	22	11	16	32	8.06
4.0	14.7	9	18	12.1	12	24	16.2	18	36	12.1
4.5	30.1	10	20	20	13	26	26.1	20	40	20
5.0	200	11	22	42.2	14	28	56.2	22	44	44.2

Table 7b: R'_{ext} for $V_o > V_{o,nom}$; approximate values ($V_{i,nom}$, $I_{o,nom}$, series E 96 resistors); R_{ext} = not fitted

$V_{o,nom} = 5.1 V$		$V_{o,nom} = 12 V$			$V_{o,nom} = 15 V$			$V_{o,nom} = 24 V$		
$V_o [V]$	$R'_{ext} [k\Omega]$	$V_o [V]^1$		$R'_{ext} [k\Omega]$	$V_o [V]^1$		$R'_{ext} [k\Omega]$	$V_o [V]^1$		$R'_{ext} [k\Omega]$
5.15	432	12.1	24.2	1820	15.2	30.4	1500	24.25	48.5	3320
5.20	215	12.2	24.4	931	15.4	30.8	768	24.50	49.0	1690
5.25	147	12.3	24.6	619	15.6	31.2	523	24.75	49.5	1130
5.30	110	12.4	24.8	475	15.8	31.6	392	25.00	50.0	845
5.35	88.7	12.5	25.0	383	16.0	32.0	316	25.25	50.5	698
5.40	75	12.6	25.2	316	16.2	32.4	267	25.50	51.0	590
5.45	64.9	12.7	25.4	274	16.4	32.8	232	25.75	51.5	511
5.50	57.6	12.8	25.6	243	16.5	33.0	221	26.00	52.0	442
		13.0	26.0	196				26.25	52.5	402
		13.2	26.4	169				26.40	52.8	383

¹ First column: V_o or V_{o1} ; second column: double-output models with outputs in series connection

Test Sockets

Test jacks (pin diameter 2 mm) for measuring the main output voltage V_o or V_{o1} are located at the front of the converter. The positive test jack is protected by a series resistor (see *Functional Description, block diagrams*).

The voltage measured at the test jacks is slightly lower than the value at the output terminals.

Display Status of LEDs

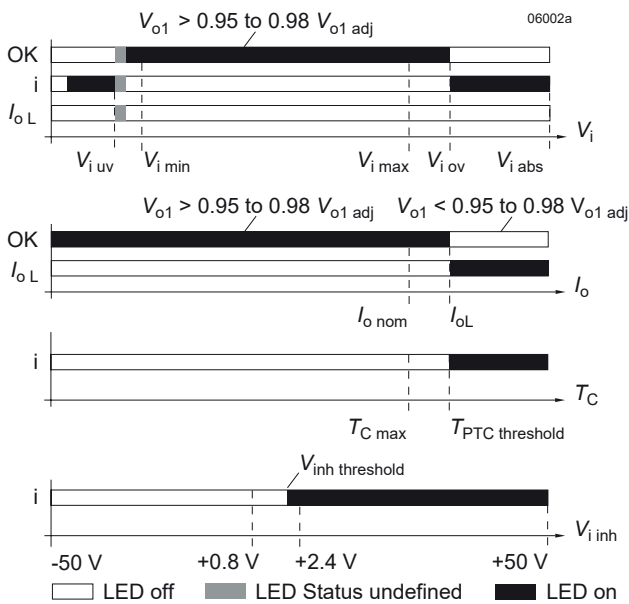

LEDs "OK", "i" and "I_{oL}" status versus input voltage
 Conditions: $I_o \leq I_{o,nom}$, $T_C \leq T_{C,max}$, $V_{inh} \leq 0.8 V$
 V_{iuv} = undervoltage lock-out, V_{iov} = overvoltage lock-out

LEDs "OK" and "I_{oL}" status versus output current
 Conditions: $V_{i,min} - V_{i,max}$, $T_C \leq T_{C,max}$, $V_{inh} \leq 0.8 V$

LED "i" versus case temperature
 Conditions: $V_{i,min} - V_{i,max}$, $I_o \leq I_{o,nom}$, $V_{inh} \leq 0.8 V$

LED "i" versus V_{inh}
 Conditions: $V_{i,min} - V_{i,max}$, $I_o \leq I_{o,nom}$, $T_C \leq T_{C,max}$

Fig. 22 LED indicators

Battery Charging / Temperature Sensor

The LS series converters are suitable for battery charger applications. For an optimum battery charging and life expectancy of the battery an external temperature sensor can be connected to the R-input. The sensor is mounted as close as possible to the battery pole and adjusts the output voltage according to the battery temperature.

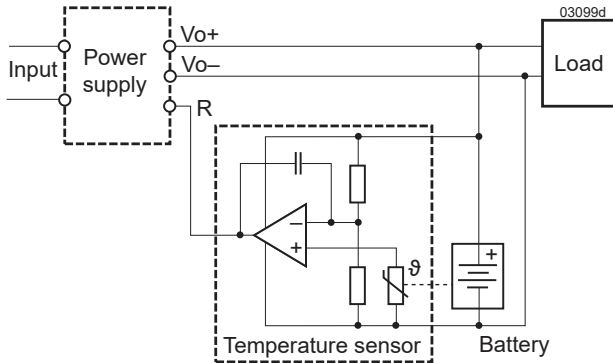

Fig. 23
Connection of a temperature sensor

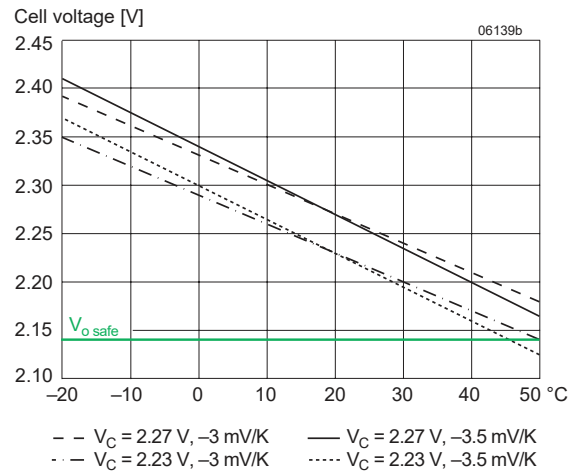

Fig. 24
Trickle charge voltage versus temperature for defined temperature coefficient. $V_{o\text{nom}}$ is the output voltage with open R-input

Electromagnetic Compatibility (EMC)

A metal oxide VDR together with an input fuse and an input filter form an effective protection against high input transient voltages, which typically occur in most installations. The S Series has been successfully tested to the following specifications:

Electromagnetic Immunity

Table 8: Electromagnetic immunity (type tests)

Phenomenon	Standard	Level	Coupling mode ¹	Value applied	Waveform	Source imped.	Test procedure	In oper.	Perf. crit. ²
Electrostatic discharge (to case)	IEC/EN 61000-4-2	4	contact discharge	8000 V _p	1/50 ns	330 Ω 150 pF	10 pos. & 10 neg. discharges	yes	A
			air discharge	15000 V _p					
Electromagnetic field	IEC/EN 61000-4-3	3	antenna	10 V/m	AM 80% / 1 kHz	N/A	80 – 1000 MHz	yes	A
			antenna	20 V/m 10 V/m 5 V/m	AM 80% / 1 kHz	N/A	800 – 1000 MHz 1400 – 2100 MHz 2100 – 2500 MHz	yes	A
		3	antenna	10 V/m	50% duty cycle, 200 Hz rep. rate	N/A	900 ± 5 MHz	yes	A
Electrical fast transients / burst	IEC/EN 61000-4-4	3	capacitive, o/c ± i/c, +i / -i direct	±2000 V _p	bursts of 5/50 ns; 2.5 / 5 kHz over 15 ms; burst period: 300 ms	50 Ω	60 s pos. & 60 s neg. transients per coupling mode	yes	A
Surges	IEC/EN 61000-4-5	3	± i/c	±2000 V _p	1.2 / 50 μs	12 Ω	5 pos. & 5 neg. surges per coupling mode	yes	A
			+i / -i	±1000 V _p		2 Ω			
Conducted disturbances	IEC/EN 61000-4-6	3	i, o, signal wires	10 VAC (140 dBμV)	AM 80% / 1 kHz	150 Ω	0.15 – 80 MHz sine wave	yes	A
Power frequency magnetic field	IEC/EN 61000-4-8	3	---	100 A/m	N/A		60 s in all 3 axes	yes	A
Pulse magnetic field	IEC/EN 61000-4-9	---	---	±300 A/m	N/A		5 pulses per axis repetit. rate 10 s	yes	B

¹ i = input, o = output, c = case

² A = Normal operation, no deviation from specifications, B = Temporary loss of function or deviation from specs possible

Electromagnetic Emissions

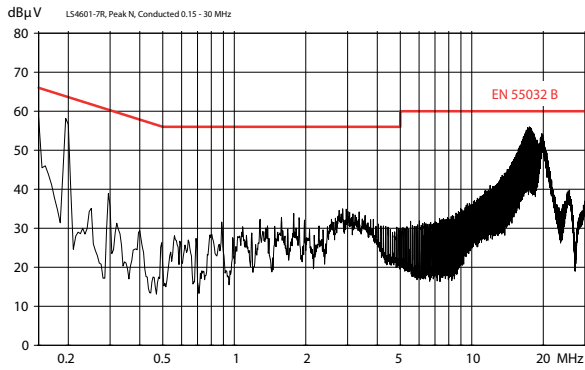

Fig. 25
 Conducted emissions (peak) at the neutral input according to EN 55011/32, measured at $V_{i\text{nom}}$ and $I_{o\text{nom}}$ (LS4601-6R). The line input performs quite similar.

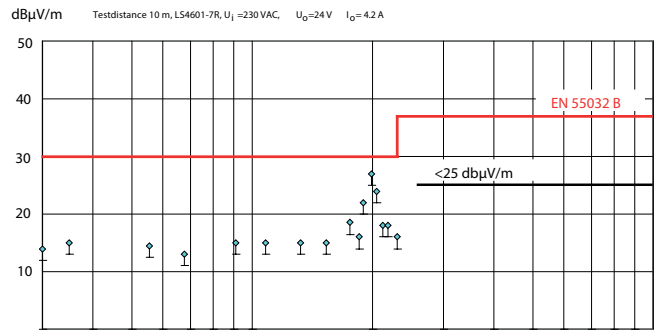

Fig. 26
 Typ. radiated emissions accord. to EN 55011/32, antenna 10 m distance, measured at $V_{i\text{nom}}$ and $I_{o\text{nom}}$ (LS4601-7R).

Immunity to Environmental Conditions

Table 9: Mechanical and climatic stress

Test method		Standard	Test Conditions		Status
Cab	Damp heat steady state	IEC/EN 60068-2-78:2001 MIL-STD-810D section 507.2	Temperature:	40 ±2 °C	Converter not operating
			Relative humidity:	93 ±2/-3 %	
			Duration:	56 days	
Ea	Shock (half-sinusoidal)	IEC/EN 60068-2-27:1987 MIL-STD-810D section 516.3	Acceleration amplitude:	100 g _n = 981 m/s ²	Converter operating
			Bump duration:	6 ms	
			Number of bumps:	18 (3 in each direction)	
Eb	Bump (half-sinusoidal)	IEC/EN 60068-2-29:1987 MIL-STD-810D sect. 516.3	Acceleration amplitude:	40 g _n = 392 m/s ²	Converter operating
			Bump duration:	6 ms	
			Number of bumps:	6000 (1000 in each direction)	
Fc	Vibration (sinusoidal)	IEC/EN 60068-2-6:1995 MIL-STD-810D section 514.3	Acceleration amplitude:	0.35 mm (10 – 60 Hz) 5 g _n = 49 m/s ² (60 - 2000 Hz)	Converter operating
			Frequency (1 Oct/min):	10 – 2000 Hz	
			Test duration:	7.5 h (2.5 h in each axis)	
Fh	Random vibration broad band (digital control)	IEC/EN 60068-2-64	Acceleration spectral density:	0.05 g _n ² /Hz	Converter operating
			Frequency band:	8 – 500 Hz	
			Acceleration magnitude:	4.9 g _{n rms}	
			Test duration:	1.5 h (0.5 h in each axis)	
Kb	Salt mist, cyclic sodium chloride (NaCl) solution	IEC/EN 60068-2-52:1996	Concentration:	5% (30 °C)	Converter not operating
			Duration:	2 h per cycle	
			Storage:	40 °C, 93% rel. humidity	
			Storage duration:	22 h per cycle	
			Number of cycles:	3	

Temperatures

Table 10: Temperature specifications, valid for an air pressure of 800 – 1200 hPa (800 – 1200 mbar)

Model		-7		Standard -9		Unit
Characteristics		min	max	min	max	
T _A	Ambient temperature	Converter operating		- 25	71	°C
T _C	Case temperature ¹	- 25	95	- 40	95	
T _S	Storage temperature	Not operating		- 40	100	

¹ Overtemperature lockout at T_C > 95 °C.

Reliability

Table 11: MTBF calculated according to MIL-HDBK 217F

Ratings at specified case temperature	Model	Ground benign 40 °C	Ground fixed		Ground mobile 50 °C	Unit
			40 °C	70 °C		
MTBF	LS 4000/5000	514 000	88 000	38 000	35 000	h

Mechanical Data

Dimensions in mm. The converters are designed to be inserted into a 19" rack, 160 mm long, according to IEC 60297-3.

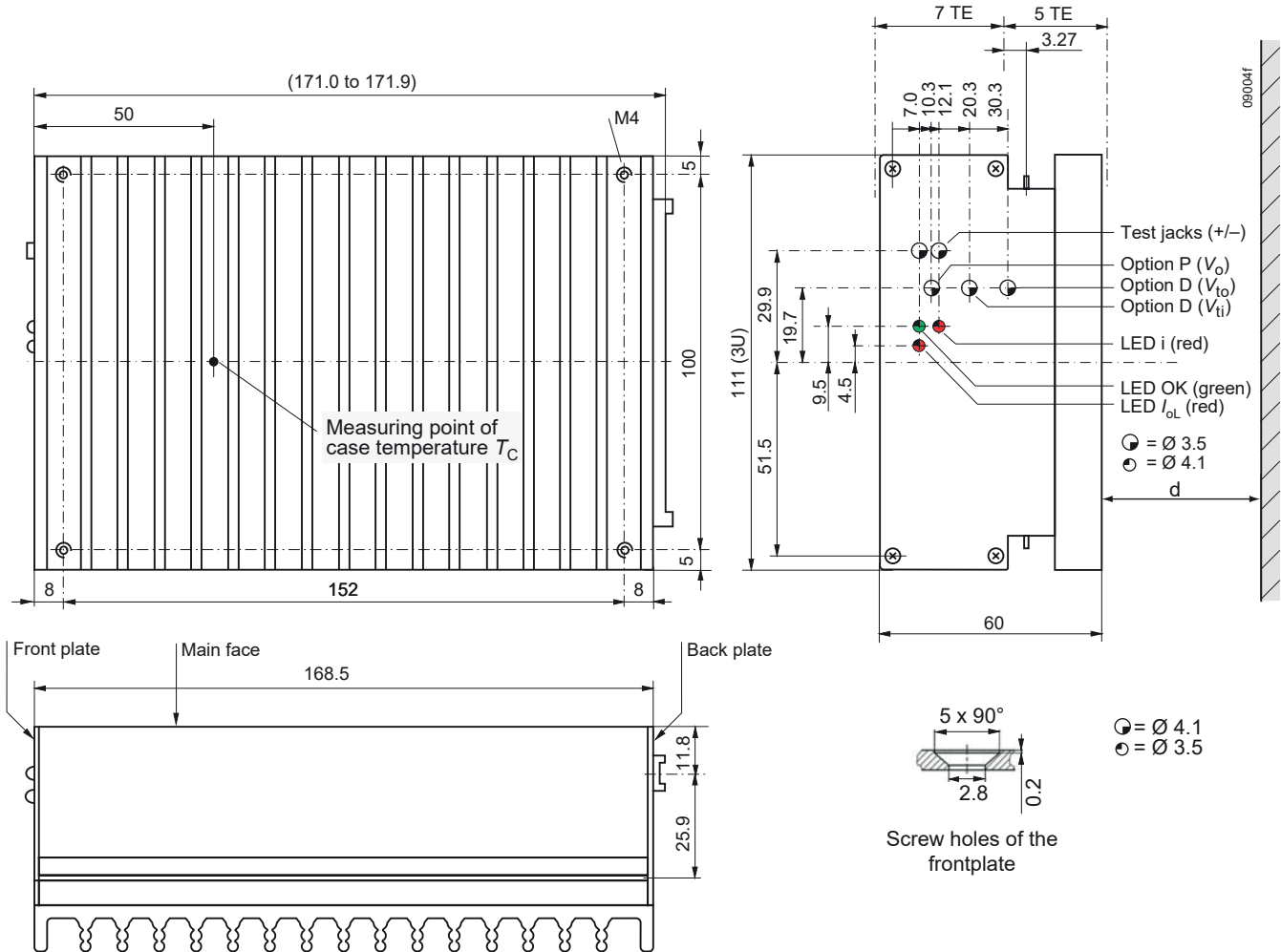

Fig. 27
Aluminum case S02 with heat sink;
black finish (EP powder coated);
weight approx. 1.25 kg

Notes:

- $d \geq 15$ mm, recommended minimum distance to next part in order to ensure proper air circulation at full output power.
- free air location: the converter should be mounted with fins in a vertical position to achieve maximum airflow through the heat sink.

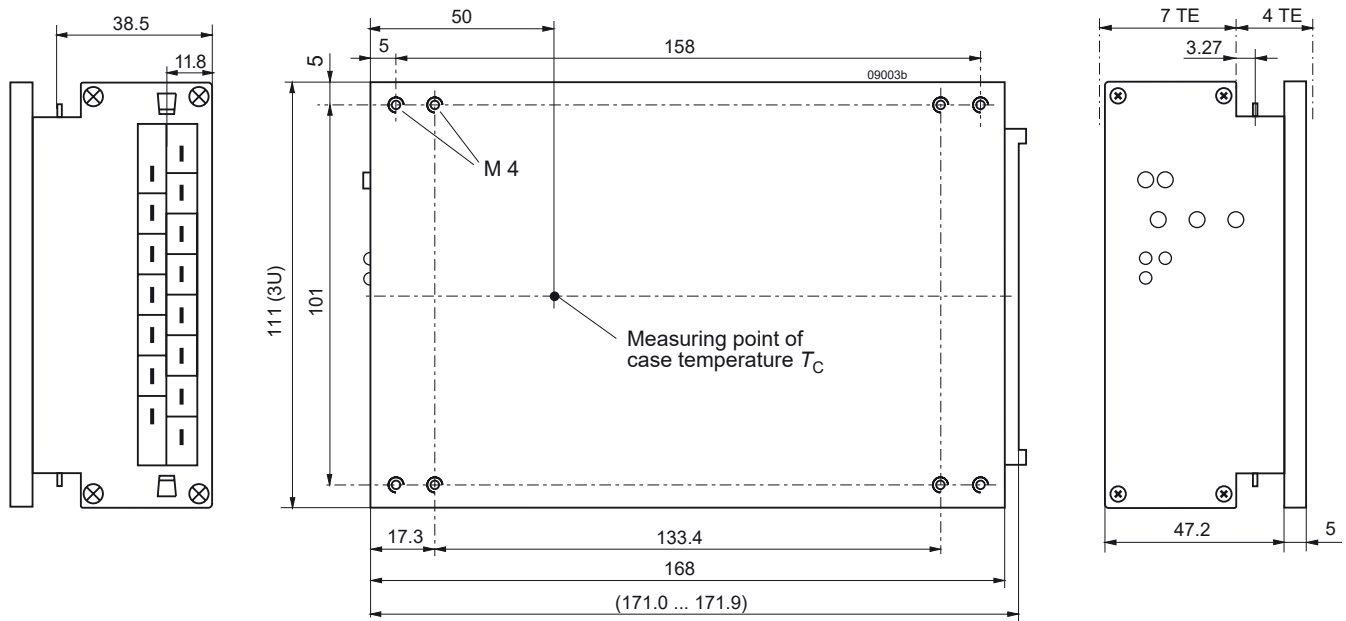

Fig. 28
 Option B1: Aluminium case S02 with small cooling plate; black finish (EP powder coated).
 Suitable for mounting with access from the backside.
 Total weight approx. 1.2 kg.

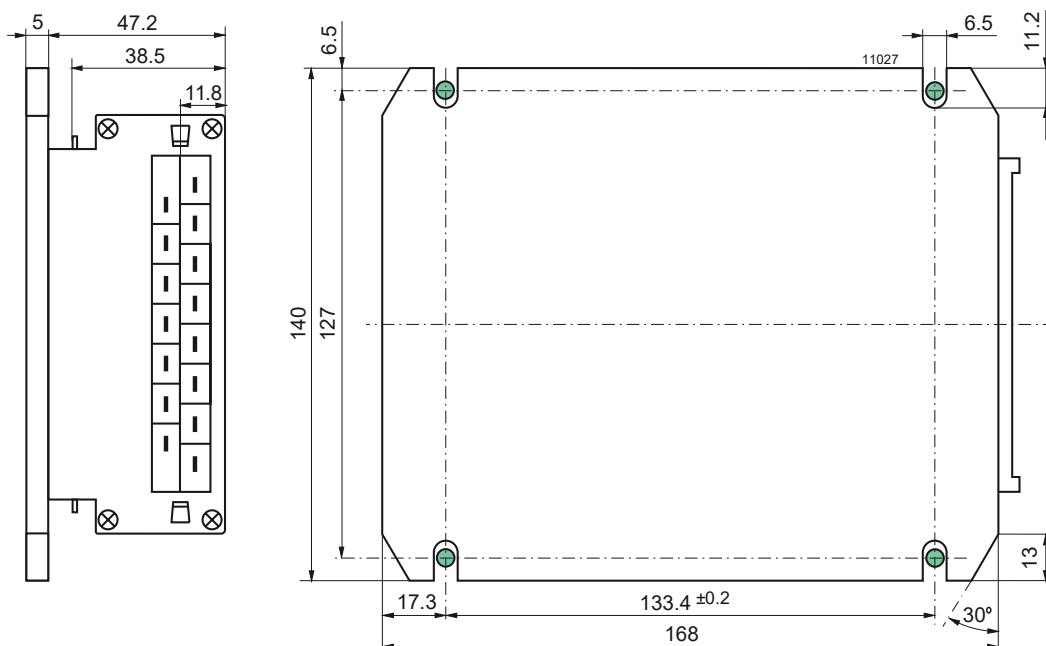

Fig. 29
 Option B: Aluminum case S02 with large cooling plate; black finish (EP powder coated).
 Suitable for front mounting.
 Total weight approx. 1.3 kg

Note: Long case with option B2, elongated by 60 mm for 220 mm rack depth, is available on request (no LEDs, no test sockets).

Safety and Installation Instructions

Connector Pin Allocation

The connector pin allocation table defines the electrical potentials and the physical pin positions on the H15 connector. The protective earth is connected through a leading pin (no. 24), ensuring that it makes contact with the female connector first.

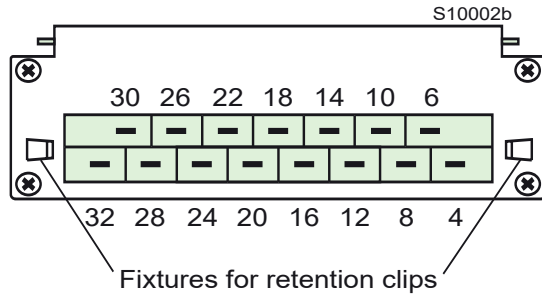

Fig. 30
View of converter's male standard H15 connector

Table 12: Pin allocation

Pin No.	Connector type H15			
	LS4000		LS5000	
4	Vo1+	Positive Output	Vo2+	Positive Output 2
6				
8	Vo1-	Negative Output	Vo2-	Negative Output 2
10				
12	S+	Positive Sense	Vo1+	Positive Output 1
14	S-	Negative Sense	Vo1-	Negative Output 1
16	R ¹	Control V _{o1}	R ¹	Control V _{o1}
18	i	Inhibit	i	Inhibit
20	D ³	Save data	D ³	Save data
	V ³	ACFAIL		
22	T ⁴	Current share	T ⁴	Current share
24 ²	⊕	Protective earth	⊕	Protective earth
26	N~	Neutral line	N~	Neutral line
28				
30	L~	Phase line	L~	Phase line
32				

¹ Not connected, if option P is fitted

² Leading pin (pre-connecting)

³ Option D excludes option V and vice versa. Pin is not connected, if neither option D or V is fitted.

⁴ Not connected, unless option T is fitted.

Installation Instructions

Important: These products have a power factor correction (PFC) and are intended to replace the LS1000 and LS2000 series converters, in order to comply with IEC/EN 61000-3-2.

Switch off the system and check for hazardous voltages before altering any connection!

These converters are components, intended exclusively for inclusion within other equipment by an industrial assembly operation or by professional installers. The installation must strictly follow the national safety regulations in compliance with the enclosure, mounting, creepage, clearance, casualty, markings, and segregation requirements of the end-use application.

Connection to the system shall be made via the female connector H15 (see *Accessories*). Other installation methods may not meet the safety requirements.

Pin no. 24 (⊕) is reliably connected with the case. For safety reasons, it is essential to connect this pin reliably to protective earth. See *Safety of Operator-Accessible Output Circuits*.

The phase input 30/32 (L~) is connected via a built-in fuse (see *Input Fuse*), which is designed to protect in the case of a converter failure. An additional external fuse, suitable for the application, might be necessary in the wiring to the other line input 26/28 (N~) if:

- Local requirements demand an individual fuse in each source line
- Neutral and earth impedance is high or undefined
- Phase and neutral of the mains are not defined or cannot be assigned to the corresponding terminals (L~ to phase and N~ to neutral).

Notes:

- If the inhibit function is not used, pin no. 18 (i) should be connected to pin no. 14 (S-/Vo1-) to enable the output(s).
- Do not open the converters, or warranty will be invalidated.
- Due to high current values, the converters provide two internally parallel contacts for certain paths (pins 4/6, 8/10, 26/28 and 30/32). It is recommended to connect load and supply to both female connector pins of each path in order to keep the voltage drop low and to not over-stress the connector contacts with high currents.
- If the second output of double-output models is not used, connect it parallel with the main output.

Make sure that there is sufficient airflow available for convection cooling. This should be verified by measuring the case temperature, when the converter is installed and operated in the end-use application. See *Thermal Considerations*.

Ensure that a converter failure (e.g., by an internal short-circuit) does not result in a hazardous condition. See also *Safety of Operator-Accessible Output Circuit*.

Standards and Approvals

The converters are safety-approved to EN/IEC 62368-1, and UL/CSA 60950-1 2nd Ed. (version 106 or greater).

The converters correspond to Class I equipment and have been evaluated for:

- Building-in
- Basic insulation between input and case based on 250 VAC, and double or reinforced insulation between input and output(s).
- Functional insulation between outputs.
- Overvoltage category II
- Pollution degree 2 environment
- Max. altitude: 2000 m.
- The converters fulfill the requirements of a fire enclosure.

All boards of the converters are coated with a protective lacquer.

The converters are subject to manufacturing surveillance in accordance with the above mentioned UL standards and [ISO 9001:2015](#). CB-scheme is available.

Protection Degree and Cleaning Liquids

Condition: Female connector fitted to the converter.

- IP 30: All models except those with option P, and except those with option D or V including a potentiometer.
- IP 20: All models fitted with option P, or with option D or V with potentiometer.

In order to avoid possible damage, any penetration of cleaning fluids is to be prevented.

Isolation and Leakage Currents

The electric strength test is performed in the factory as routine test in accordance with EN 62911 and IEC/EN 662368-1. The company will not honor warranty claims resulting from incorrectly performed electric strength field tests.

Leakage currents flow due to internal leakage capacitances and Y-capacitors. The current values are proportional to the supply voltage and are specified in the table below.

Table 13: Leakage currents

Characteristics		Class I	Unit
Max. earth leakage current	Permissible accord. to IEC/EN 62368-1	5.0	mA
	Typ. value at 254 V, 50 Hz (LS models)	0.95	

Table 14: Isolation

Characteristics		Input to Case + Output(s)	Output(s) to Case	Output 1 to Output 2	Unit
Electric strength test	Factory test > 1 s	2.8 ¹	1.4	0.15	kVDC
	AC test voltage equivalent to factory test	2.0	1.0	0.1	kVAC
Insulation resistance at 500 VDC		>300	>300	>100 ²	MΩ
Creepage distances		≥ 3.2 ³	---	---	mm

¹ Subassemblies connecting input to output are pre-tested with 5.6 kVDC or 4 kVAC.

² Tested at 150 VDC

³ Input to outputs: 6.4 mm

Railway Applications and Fire Protection

The converters have been designed by observing the railway standards EN 50155 and EN 50121-4. All boards are coated with a protective lacquer.

The converters with version V108 (or later) comply with NF-F16 (I2/F1). They also accord to EN 45545-1, EN 45545-2 (2013), if installed in a technical compartment or cabinet.

Safety of Operator-Accessible Output Circuits

If the output circuit of an converter is operator-accessible, it shall be an ES1 circuit according to IEC/EN 62368-1.

The table below shows a possible installation configuration, compliance with which causes the output circuit of an S Series AC-DC converter to be an ES1 circuit according to IEC/EN 62368-1 up to a configured output voltage of 36 V (sum of nominal output voltages connected in series).

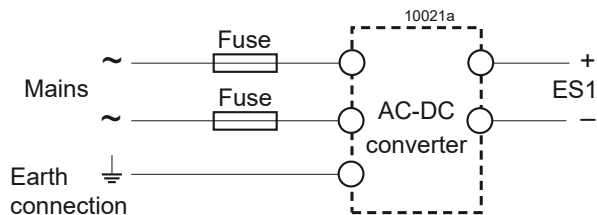

Fig. 31
Schematic safety concept.

Table 15: Safety concept leading to an ES1 output circuit

Conditions	AC-DC converter	Installation	Result
Nominal voltage	Grade of insulation between input and output provided by the AC-DC converter	Measures to achieve the resulting safety status of the output circuit	Safety status of the AC-DC converter output circuit
Mains ≤ 250 VAC	Double or reinforced	Earthed case ¹ and installation	ES1 circuit

¹ The earth connection has to be provided by the installer according to the relevant safety standards, e.g. IEC/EN 62368-1.

Description of Options

Table 16: Survey of options

Option	Function of option	Characteristics
- 7, -7E	Restricted operational ambient temperature range	$T_A = -25$ to 71 °C (not for new designs)
E	Electronic inrush current limitation circuitry	Active inrush current limiter, standard feature for $T_A = -40$ °C
P ²	Potentiometer for fine adjustment of output voltage	Adjustment range $+10/-60\%$ of $V_{o,nom}$; excludes R-input
D ¹	Input and/or output undervoltage monitoring circuitry	Safe data signal output (D0 – DD)
V ¹	Input and/or output undervoltage monitoring circuitry	ACFAIL signal according to VME specifications (V0, V2, V3)
T	Current sharing	Interconnect T-pins for parallel connection (max 5 converters)
B, B1, B2	Cooling plate (160 or 220 mm long)	Replaces the standard heat sink, allowing direct chassis-mounting
G	RoHS-compliant for all six substances	G is always the last character in the type designation

- ¹ Option D excludes option V and vice versa; option V only for 5.1 V outputs.
² Option P is not available for battery charger models.

-7 Restricted Temperature Range

Option -7 and -7E stand for a restricted operational ambient temperature range of -25 to 71 °C rather than -40 to 71 °C.

E Inrush Current Limitation

The converters exhibit an electronic circuit replacing the standard built-in NTC, in order to achieve an enhanced inrush current limiting function (standard feature).

Note: Subsequent switch-on cycles at start-up are limited to max. 10 cycles during the first 20 seconds (cold converter) and then to max. 1 cycle every 8s.

Table 17: Inrush current characteristics with option E

Characteristics $V_i = 230$ VAC		LS			Unit
		min	typ	max	
$I_{inr,p}$	Peak inrush current		---	25.3	A
t_{inr}	Inrush current duration		35	50	ms

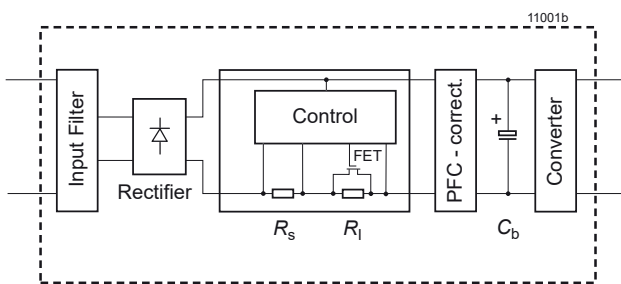

Fig. 32
Block diagram for option E

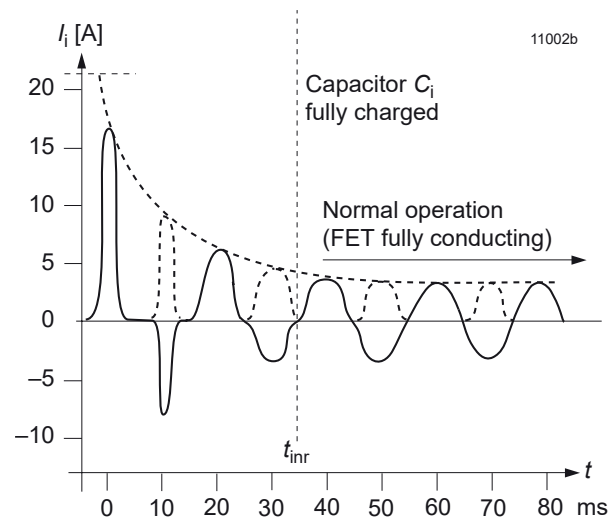

Fig. 33
Typ. inrush current with option E
 $V_i = 230$ VAC, $f_i = 50$ Hz, $P_o = P_{o,nom}$

P Potentiometer

A potentiometer provides an output voltage adjustment range of +10/-60% of $V_{o,nom}$. It is accessible through a hole in the front cover. Option P is not available for battery charger models and is not recommended for converters connected in parallel.

Option P excludes the R-function. With double-output models, both outputs are influenced by the potentiometer setting (doubling the voltage, if the outputs are in series).

If the output voltages are increased above $V_{o,nom}$ via R input control, option P setting, remote sensing or option T, the output current(s) should be reduced accordingly, so that $P_{o,nom}$ is not exceeded.

T Current Sharing

This option ensures that the output currents are approximately shared between all parallel-connected converters, hence increasing system reliability. To use this facility, simply interconnect the T pins of all converters and make sure that the reference for the T signal, pin 14 (S- or the Vo1-), are also connected together. The load lines should have equal length and cross section to ensure equal voltage drops.

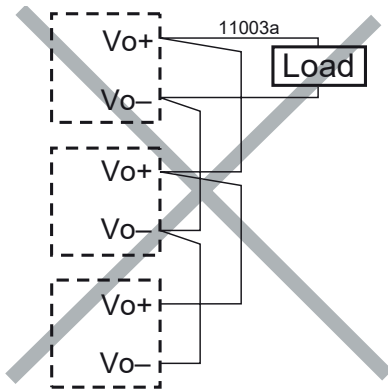
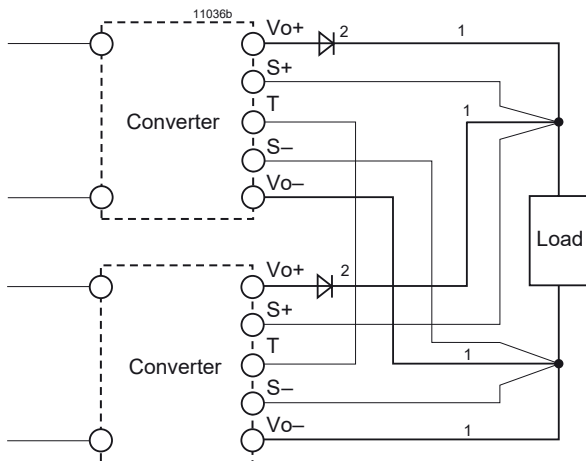

Fig. 34 Example of poor wiring for parallel connection (unequal length of load lines)

Not more than 5 converters should be connected in parallel. The R pins should be left open-circuit. If not, the output voltages must be individually adjusted prior to paralleling within 1 to 2% or the R pins should be connected together.

Parallel connection of converters with option P is not recommended.



Max. 5 converters in parallel connection

¹ Lead lines should have equal length and cross section, and should run in the same cable loom.
² Diodes recommended in redundant operation only

Fig. 35 Parallel connection of single-output models using option T with the sense lines connected at the load

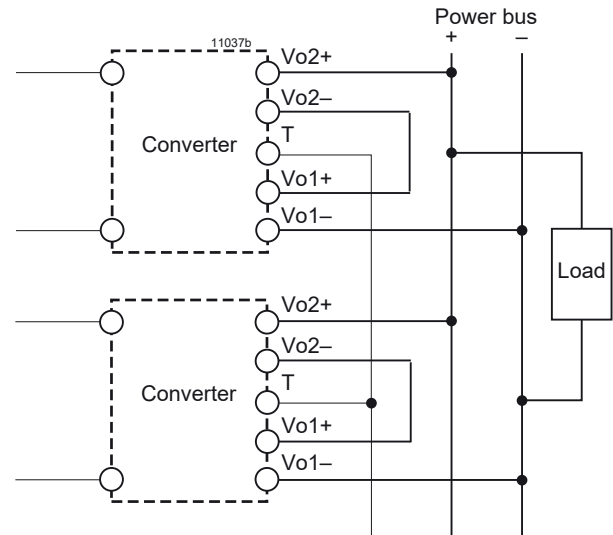

Max. 5 converters in parallel connection

Fig. 36 Parallel connection of double-output models with the outputs connected in series, using option T. The signal at the T pins is referenced to Vo1-.

D Undervoltage Monitor

The input and/or output undervoltage monitoring circuit operates independently of the built-in input undervoltage lockout circuit. A logic “low” (self conducting JFET) or “high” signal (NPN output) is generated at the D output (pin 20), when one of the monitored voltages drops below the preselected threshold level V_t . This signal is referenced to S-/Vo1-. The D output recovers, when the monitored voltages exceed $V_t + V_h$. The threshold level V_{bi} is adjusted in the factory. The threshold level V_{to} is either adjusted by a potentiometer accessible through a hole in the front cover, or adjusted in the factory to a fixed value specified by the customer. Option D exists in various versions D0 – DD, as shown in the table below.

Table 18: Undervoltage monitoring functions

Output type		Monitoring		Minimum adjustment range of threshold level V_t		Typ. hysteresis V_{ho} [% of V_t] for $V_{t\min} - V_{t\max}$ V_{ho}
JFET	NPN	V_i	V_o or V_{o1}	V_{tb} ⁴	V_{to}	
D1	D5	no	yes	---	$3.5 - V_{BR}^1$	2.5 – 0.6 V
D2	D6	yes	no	355 VDC	---	---
D3	D7	yes	yes	355 VDC	$(0.95 - 0.985 V_{o1})^2$	“0”
D4	D8	no	yes	---	$(0.95 - 0.985 V_{o1})^2$	“0”
D0	D9	no	yes	---	$3.5 - V_{BR}^3$	2.5 – 0.6 V
		yes	yes	355 VDC	$3.5 - V_{BR}^3$	2.5 – 0.6 V
---	DD	yes	yes	355 VDC	$3.5 - V_{BR}^1$	2.5 – 0.6 V

- ¹ Threshold level adjustable by potentiometer. See *Output Data* for V_{BR} .
- ² Fixed value. Tracking if V_{o1} is adjusted via R-input, option P, or sense lines.
- ³ The threshold level permanently adjusted according to customer specification $\pm 2\%$ at 25 °C. Any value within the specified range is basically possible, but causes a special type designation in addition to the standard option designations (D0/D9).
- ⁴ V_b is the voltage generated by the boost regulator. When V_b drops below 355 V, the D signal triggers, and the output(s) will remain powered during nearly the full hold-up time t_h .

JFET output (D0 – D4):

Pin D is internally connected via the drain-source path of a JFET (self-conducting type) to the negative potential of output 1. $V_D \leq 0.4$ V (logic low) corresponds to a monitored voltage level (V_i and/or V_{o1}) $< V_t$. The current I_D through the JFET should not exceed 2.5 mA. The JFET is protected by a 0.5 W Zener diode of 8.2 V against external overvoltages.

NPN output (D5 – DD):

Pin D is internally connected via the collector-emitter path of a NPN transistor to the negative potential of output 1. $V_D < 0.4$ V (logic low) corresponds to a monitored voltage level (V_i and/or V_{o1}) $> V_t + V_h$. The current I_D through the open collector should not exceed 20 mA. The NPN output is not protected against external overvoltages. V_D should not exceed 40 V.

Table 19: JFET output (D0 -- D4)

V_b, V_{o1} status	D output, V_D
V_b or $V_{o1} < V_t$	low, L, $V_D \leq 0.4$ V at $I_D = 2.5$ mA
V_b and $V_{o1} > V_t + V_h$	high, H, $I_D \leq 25$ μ A at $V_D = 5.25$ V

Table 20: NPN output (D5 – DD)

V_b, V_{o1} status	D output, V_D
V_b or $V_{o1} < V_t$	high, H, $I_D \leq 25$ μ A at $V_D = 40$ V
V_b and $V_{o1} > V_t + V_h$	low, L, $V_D \leq 0.4$ V at $I_D = 20$ mA

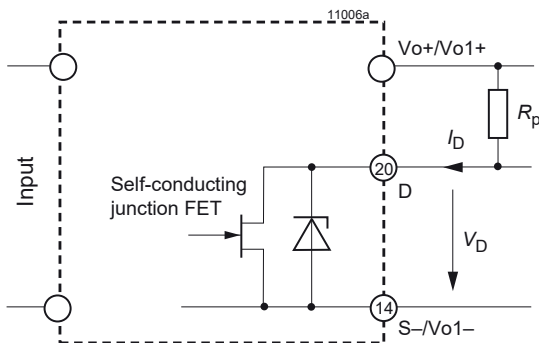

Fig. 37
Option D0 – D4: JFET output, $I_D \leq 2.5$ mA

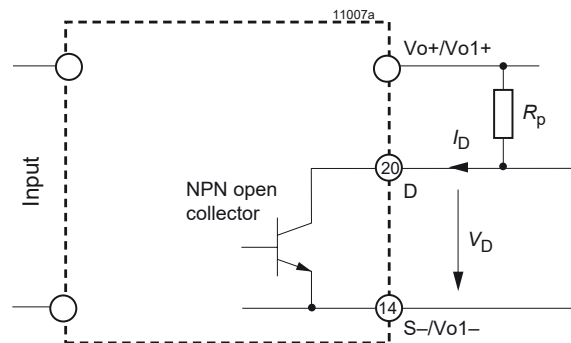
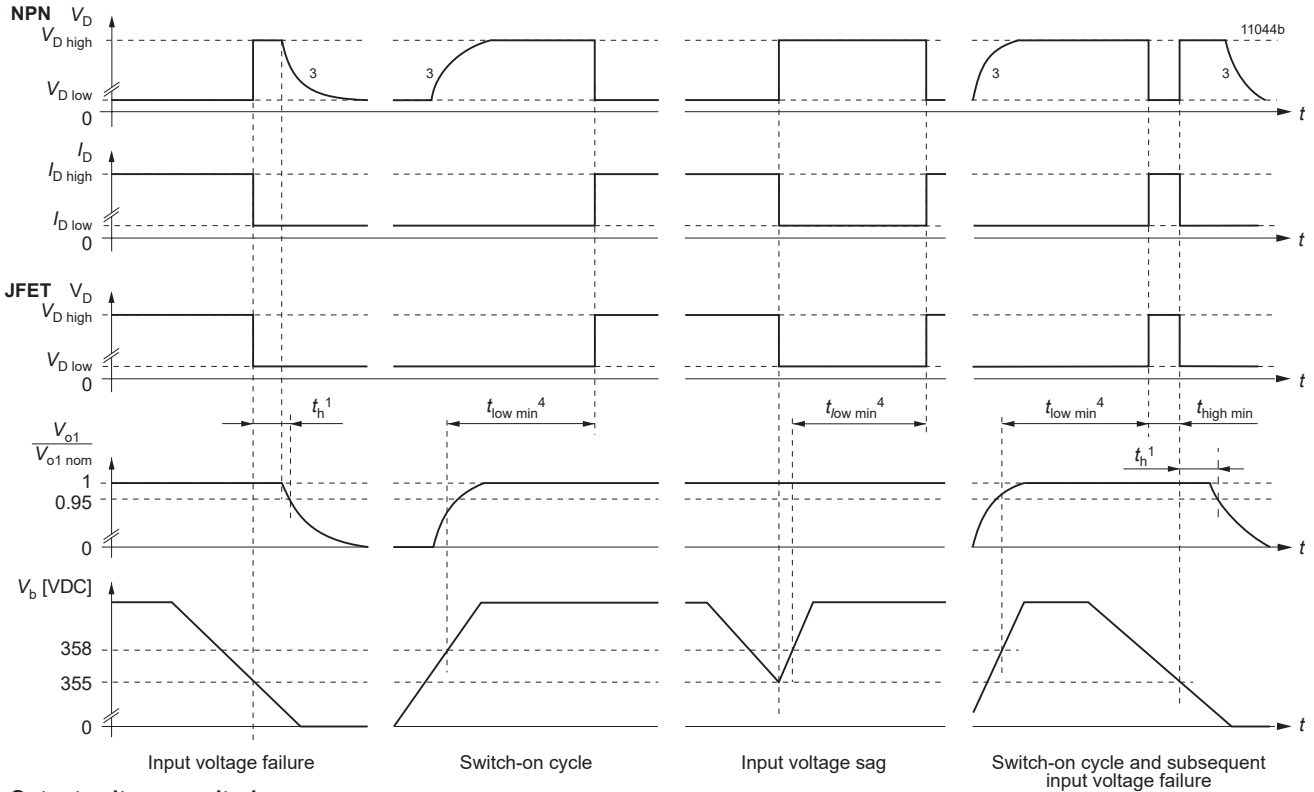

Fig. 38
Option D5 – DD: NPN output, $V_o \leq 40$, $I_D \leq 2.5$ mA

Table 21: D-output logic signals

Version of D	$V_i < V_t$ or $V_o < V_t$	$V_i > V_t + V_h$ or $V_o > V_t$	Configuration
D1, D2, D3, D4, D0	low	high	JFET
D5, D6, D7, D8, D9, DD	high	low	NPN

Input voltage monitoring



Output voltage monitoring

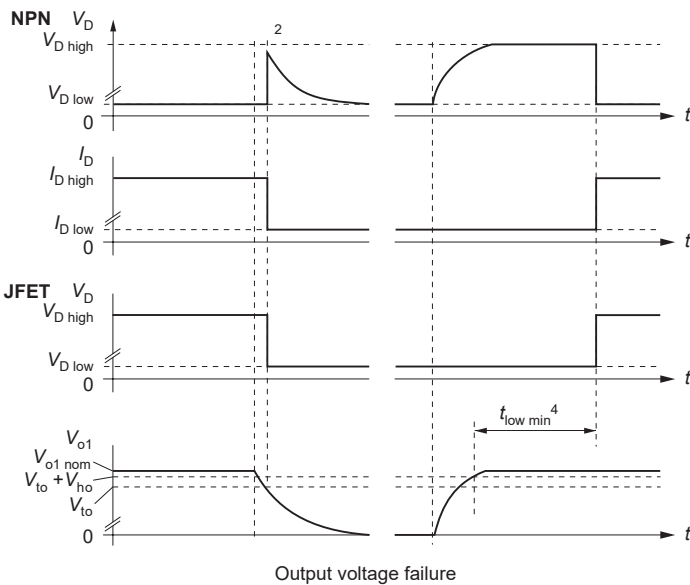

- 1 Hold-up time see: *Electrical Input Data*.
- 2 With output voltage monitoring, hold-up time $t_h = 0$.
- 3 The signal remains high, if the D output is connected to an external source.
- 4 $t_{\text{low min}} = 100 - 170$ ms, typically 130 ms

Fig. 39 Relationship between V_b , V_{o1} , V_D , $V_{o1}/V_{o1\text{ nom}}$ versus time

V ACFAIL Signal (VME)

Available only for models with $V_o = 5.1$ V.

This option defines an undervoltage monitoring circuit for the input and main output voltage. It generates the ACFAIL signal (V_V signal) according to the VME standard.

The low state level of the ACFAIL signal is specified at a sink current of $I_V \leq 48$ mA to $V_V \leq 0.6$ V (open-collector output of an NPN transistor). The pull-up resistor feeding the open-collector output should be placed on the VME backplane.

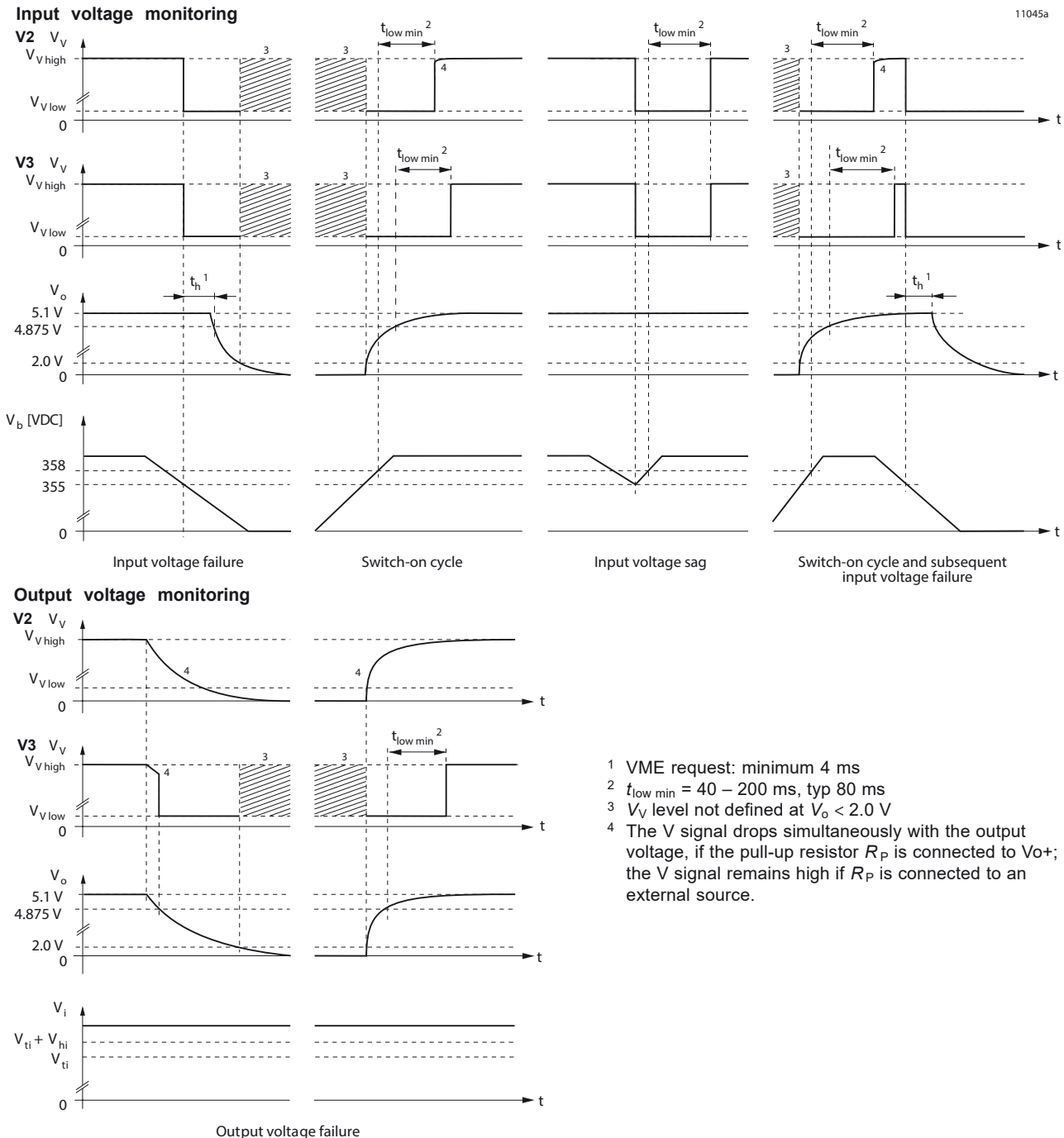

Fig. 40 V_{cb} , V_o , V_V , I_V , $V_o/V_{o\ nom}$ versus time.

After the ACFAIL signal has gone low, the VME standard requires a hold-up time t_h of at least 4 ms before the 5.1 V output drops at full load to 4.875 V. This hold-up time t_h is provided by the capacitance supporting the boost voltage V_b . See *Hold-up Time*.

Option V operates independently of the built-in input undervoltage lockout circuit. A logic “low” signal is generated at pin 20, as soon as one of the monitored voltages drops below the preselected threshold level V_t . The return for this signal is S– or Vo1–. The V output recovers, when the monitored voltage(s) exceed(s) $V_t + V_n$. The threshold level V_o is adjusted in the factory to a customer-specified value.

Table 22: Undervoltage monitor functions

V output (VME compatible)	Monitoring		Minimum adjustment range of threshold level	
	V_b	V_{o1}	V_{tb}	V_{to}
V2	yes	no	355 VDC ¹	
V3	yes	yes	355 VDC ¹	0.95 – 0.985 V_{o1} ²

¹ Option V monitors V_b generated by the boost regulator. The trigger level is adjusted in the factory to 355 VDC.
² Fixed value between 95% and 98.5% of V_{o1}

Table 23: Status of V output

V_b, V_{o1} status	D output, V_V
V_b or $V_{o1} < V_t$	low, L, $V_V \leq 0.6$ V at $I_V = 50$ mA
V_b and $V_{o1} > V_t + V_n$	high, H, $I_V \leq 25$ μ A at $V_V = 5.1$ V

V-output (V2, V3):

Connector pin V is internally connected with the open collector of an NPN transistor. The emitter is connected with S– or Vo1–. $V_V \leq 0.6$ V (logic low) corresponds to a monitored voltage level (V_t and/or V_o) $< V_t$. The current I_V through the open collector should not exceed 50 mA. The NPN output is not protected against external overvoltages. V_V should not exceed 60 V.

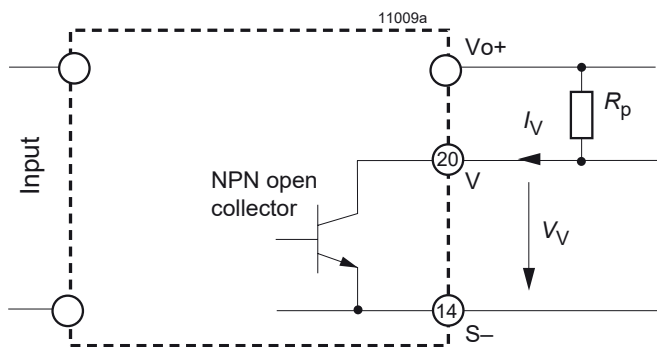

Fig. 41
Output configuration of options V2 and V3

B, B1, B2 Cooling Plate

Where a cooling surface is available, we recommend the use of a cooling plate instead of the standard heat sink. The mounting system should ensure sufficient cooling capacity to guarantee that the maximum case temperature $T_{C_{max}}$ is not exceeded. The cooling capacity is calculated by:

$$P_{Loss} = \frac{(100\% - \eta)}{\eta} \cdot V_o \cdot I_o$$

Efficiency η see *Model Selection*.

For the dimensions of the cooling plates, see *Mechanical Data*. Option B2 is for customer-specific models with elongated case (for 220 mm DIN-rack depth) only.

G RoHS

Models with G as last character of the type designation are RoHS-compliant for all six substances.

Accessories

A variety of electrical and mechanical accessories are available including:

- Front panels for 19" DIN-rack: Schroff or Intermas, 12 TE /3U; see fig. 42
- Mating H15 connectors with screw, solder, faston, or press-fit terminals, code key system and coding wedges HZZ00202-G; see fig. 43.
- Pair of connector retention clips HZZ01209-G; see fig. 44
- Connector retention brackets HZZ01216-G; see fig. 45.
- Cage clamp adapter HZZ00144-G; see fig. 46
- Different cable hoods for H15 connectors (fig. 47):
 - HZZ00141-G, screw version
 - HZZ00142-G, use with retention brackets HZZ01218-G
 - HZZ00143-G, metallic version providing fire protection
- Chassis or wall-mounting plate K02 (HZZ01213-G) for models with option B1. Mating connector (HZZ00107-G) with screw terminals; see fig. 48
- DIN-rail mounting assembly HZZ0615-G (DMB-K/S); see fig. 49
- Additional external input and output filters
- Different battery sensors S-KSMH... for using the converter as a battery charger. Different cell characteristics can be selected; see fig. 50, table 24, and *Battery Charging/Temperature Sensors*.

For additional accessory product information, see the accessory data sheets listed with each product series or individual model at www.belfuse.com/power-solutions.



Fig. 42
Different front panels



Fig. 43
Different mating connectors

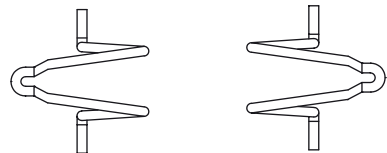

Fig. 44
Connector retention clips to fasten the H15 connector to the rear plate; see fig. 24. HZZ01209-G consists of 2 clips.

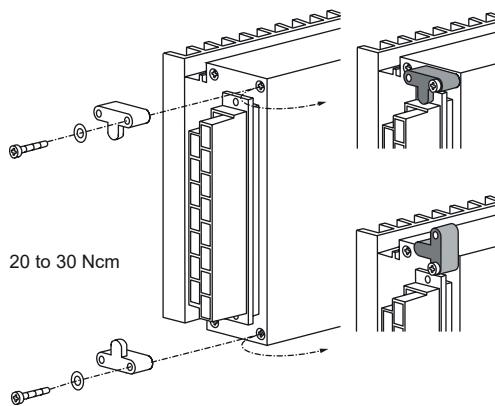

Fig. 45
Connector retention brackets HZZ01216-G (CRB-HKMS)

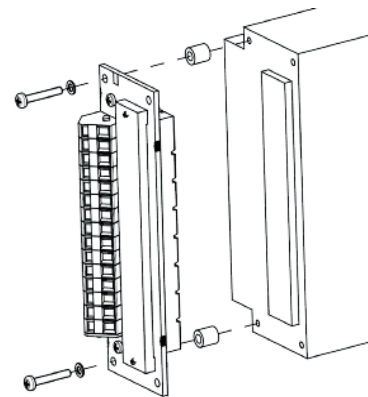

Fig. 46
Cage clamp adapter HZZ00144-G

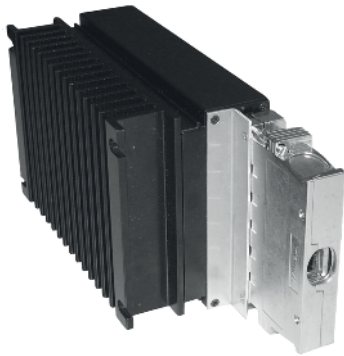

Fig. 47
Different cable hoods



Fig. 48
Chassis- or wall-mounting plate HZZ01213-G (Mounting plate K02)



Fig. 49
DIN-rail mounting assembly HZZ00615-G (DMB-K/S)

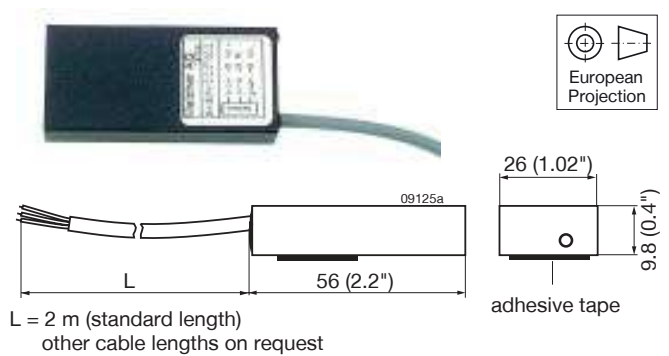

Fig. 50
Battery temperature sensor

Table 24: Battery temperature sensors

Battery voltage nom. [V]	Sensor type	Cell voltage [V]	Cell temp. coefficient [mV/K]	Cable length [m]
12	S-KSMH12-2.27-30-2	2.27	-3.0	2
12	S-KSMH12-2.27-35-2	2.27	-3.5	2
24	S-KSMH24-2.27-30-2	2.27	-3.0	2
24	S-KSMH24-2.27-35-2	2.27	-3.5	2
24	S-KSMH24-2.31-35-0	2.31	-3.5	4.5
24	S-KSMH24-2.31-35-2	2.31	-3.5	2
24	S-KSMH24-2.35-35-2	2.35	-3.5	2
48	S-KSMH48-2.27-30-2	2.27	-3.0	2
48	S-KSMH48-2.27-35-2	2.27	-3.5	2

Note: Other temperature coefficients and cable lengths are available on request.

NUCLEAR AND MEDICAL APPLICATIONS - These products are not designed or intended for use as critical components in life support systems, equipment used in hazardous environments, or nuclear control systems.

TECHNICAL REVISIONS - The appearance of products, including safety agency certifications pictured on labels, may change depending on the date manufactured. Specifications are subject to change without notice.