

REVISIONS				
P	LTR	DESCRIPTION	DATE	APVD
H2		REVISED PER ECR-22-158429	23DEC2022	LP DSP

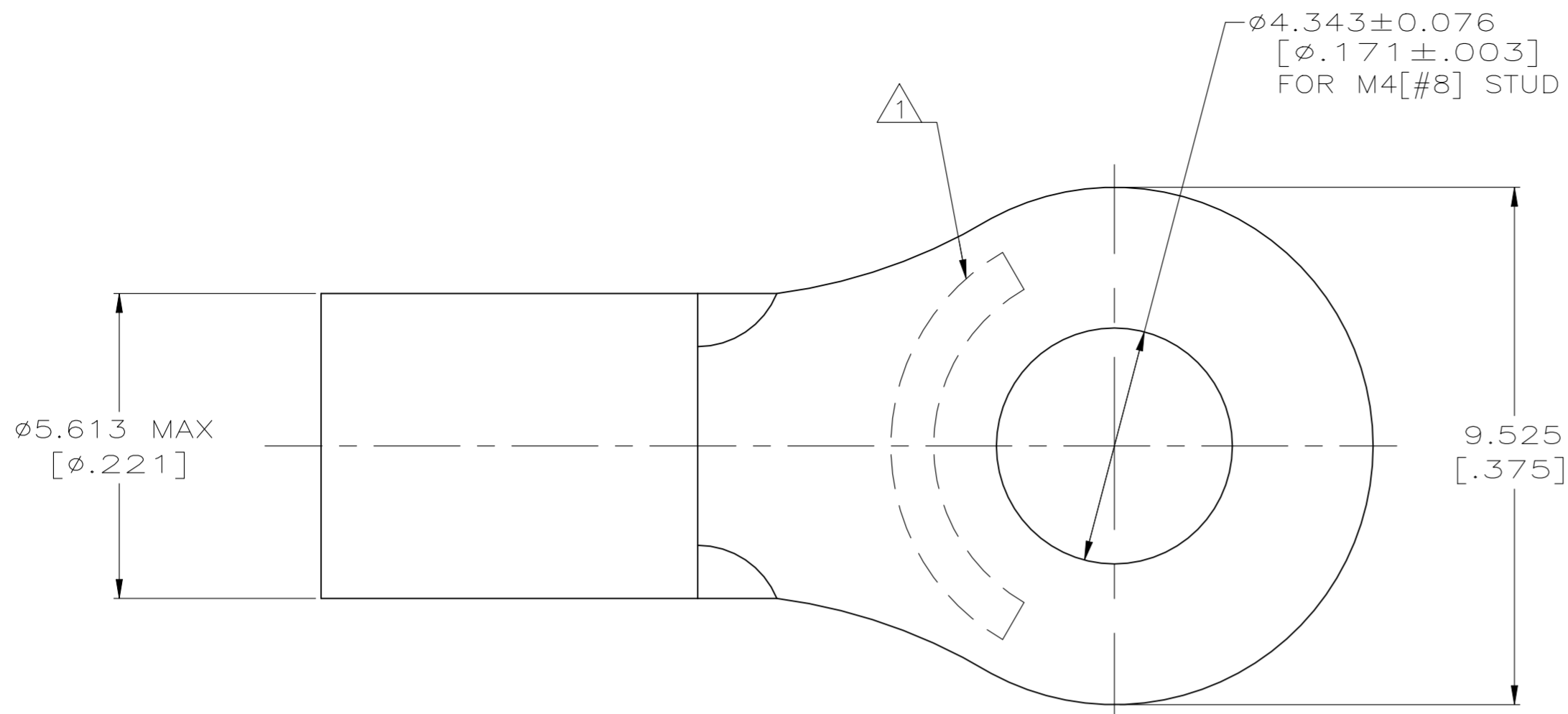

AMP WIRE RANGE	E13288 Listed
12-10 AWG STRANDED	12-10 AWG STRANDED

- 1 STAMP AMP 12-10* APPROX AS SHOWN
- 2 MATERIAL THICKNESS: 0.991±0.051 [.039±.002]
- 3 MATERIAL: COPPER PER ASTM B152
- 4 FINISH: TIN PLATE 0.00254 [.00010] MIN EXT THK PER ASTM B545
- 5 UL LISTED, E13288

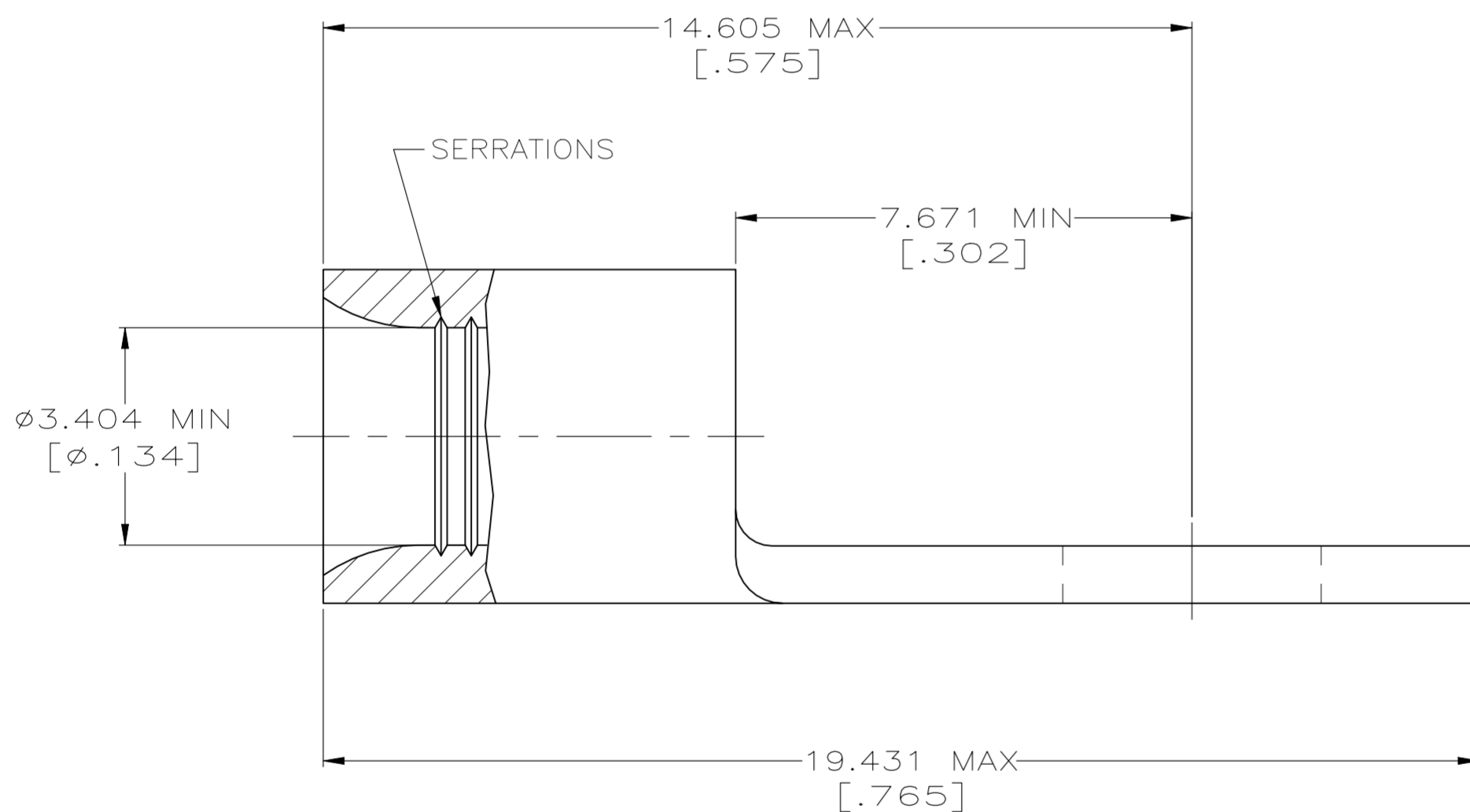

**AMP INCORPORATED
CUSTOMER SERVICE SYSTEMS**

MAX RECOMMENDED OPERATING TEMPERATURE:
170° C [338° F] MAX

FOR ADDITIONAL PRODUCT INFORMATION OR COPIES OF DRAWINGS AND TECHNICAL DOCUMENTS

PRODUCT INFORMATION CENTER
1-800-522-6752

VOLTAGE RATING:
NOT APPLICABLE

FOR APPLICATION TOOLING INFORMATION

TOOLING ASSISTANCE CENTER
1-800-722-1111

WIRE CROSS SECTIONAL AREA RANGE:
2.62-6.64mm² [5,180-13,100] CIR MILS STRANDED

FOR ORDER ENTRY

1-800-526-5142

THIS DRAWING IS A CONTROLLED DOCUMENT FOR AMP INCORPORATED. IT IS SUBJECT TO CHANGE AND THE CONTROLLING ENGINEERING ORGANIZATION SHOULD BE CONTACTED FOR THE LATEST REVISION.

2500	TAPE & REEL	3-31113-2
500	LOOSE PIECE	31113
QTY	PACKAGE TYPE	PART NUMBER

THIS DRAWING IS A CONTROLLED DOCUMENT.		DWN TA BRINKMAN 2-8-93	TE Connectivity	
DIMENSIONS: mm [INCHES]		CHK DA PATTERSON 2-8-93		
TOLERANCES UNLESS OTHERWISE SPECIFIED:		APVD -	NAME -	
0 PLC ± -		PRODUCT SPEC UL 486A-B	TERMINAL, RING TONGUE, BUDGET, WIRE SIZE: 12-10 AWG	
1 PLC ± -		APPLICATION SPEC -	SIZE A2	CAGE CODE 00779
2 PLC ± -		WEIGHT -	DRAWING NO C=31113	RESTRICTED TO -
3 PLC ± 0.127[.005]		SCALE 10:1 SHEET 1 of 1 REV H2		
4 PLC ± -		CUSTOMER DRAWING		
ANGLES ± -				