

## Alternator voltage regulator with LIN interface for 12 V applications

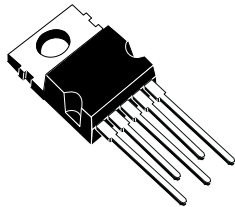

PENTAWATT In Line

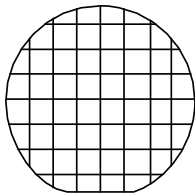

Bare die

### Features

- AEC-Q100 qualified 
- Closed loop voltage control
- Regulated voltage with thermal compensation function
- High side excitation driver with internal freewheeling circuit
- Load response control (LRC) and Return LRC
- Self-start activation by phase signal
- Current limitation and overcurrent protection
- Thermal protection
- Physical Layer compliant with LIN 2.2A spec.
- Data Link Layer compliant with LIN 1.3, 2.1, 2.2 and 2.2A specification
- 13 sets of LIN frames selectable
- Configurable parameters (see NVM parameter table A1)
- Configurable for 5, 6, 7, 8 or 9 pole pair alternator
- Compliant to VDA LIN-Generator-Regulator specification
- Full ISO26262 compliant, ASIL-B systems ready
- Available as Bare die as well as in PENTAWATT In Line (TO220-5) package

### Description

L9918 is an alternator voltage regulator equipped with LIN protocol interface. The device is intended to be used in automotive application for 12 V systems. The presence of NVM cells for device parameters programmability makes it suitable for a wide range of charging application.

Product status link		
<a href="#">L9918</a>		
Product summary		
Order code	Package	Packing
L9918	PENTAWATT In Line (TO220-5)	Tube
L9918BDTR	Bare die	Tape&Reel

## 1 Functional description

The device is an alternator voltage regulator suited for 12 V system, able to communicate with ECU through LIN communication protocol.

The device is housed into an alternator brush holder and it provides current to the excitation coil of the alternator (rotor) through a high side power MOSFET driver. The device is suitable for alternators with different poles pair number. An active freewheeling circuit is also integrated into the device.

Target function of the device is to modulate the rotor current in order to keep the voltage on car loads steady to a target value (set point), whatever the vehicle demand.

The set point target is typically commanded by the ECU and it is achieved using an internal voltage reference. Set point is communicated along with many others functional parameters during the regular device functioning.

Slew rate control in combination with external filtering of the interface lines helps to realize electromagnetic compatibility.

Figure 1. Simplified application diagram

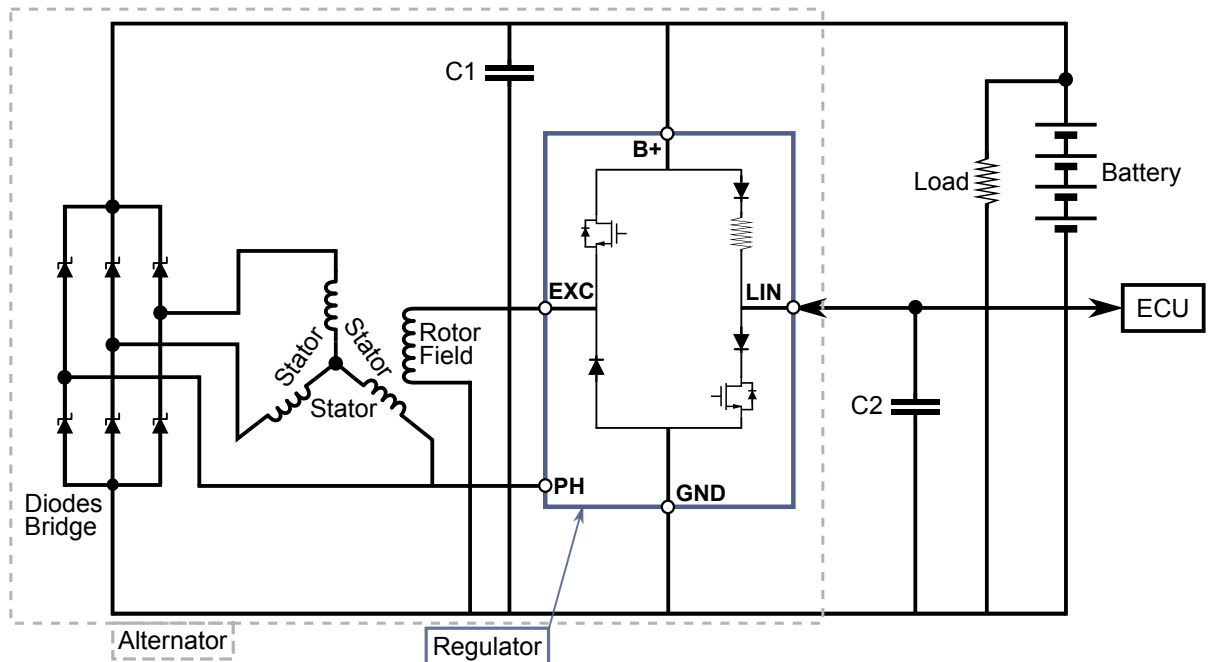

### 1.1 External component required

The capacitors C1 (2.2  $\mu$ F ceramic suggested) and C2 (220 pF suggested) to suppress radio frequency injection have to be connected as close as possible between the related pin and GND.

## 1.2 Pin description

**Figure 2. Pins connection diagram (top view)**

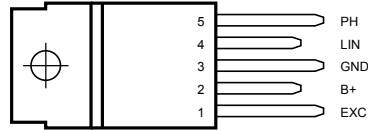

**Table 1. Pin description**

N°	PIN	Function
1	EXC	High side driver output to control the rotor current
2	B+	Device power supply and Battery voltage sensing
3	GND	Regulator ground
4	LIN	Communication terminal
5	PH	Phase sense input

### 1.2.1 EXC

This pin is connected to the excitation coil (rotor) of the alternator. The IC supplies a current to the rotor in order to control the output current of the alternator when car load or car speed varies. Device target is to maintain battery voltage at defined set point. Inside the device is also embedded a freewheeling circuit, needed to discharge the rotor current when the High Side power is turned OFF.

### 1.2.2 B+

The device is supplied by this pin. This voltage is also used as feedback voltage by the regulation loop.

### 1.2.3 GND

The device has one GND pin.

### 1.2.4 LIN

This LIN pin represents the single-wire bus transmitter and receiver. It is suited for automotive bus systems and is based on LIN protocol defined in LIN bus specification v1.3, v2.1, v2.2 and v2.2A.

### 1.2.5 PH

This pin is connected to one of the stator windings. Its input signal is used for rotor speed measurement, stator voltage monitoring as well as self-start detection. During the regulation, phase signal voltage level is continuously monitored. Phase regulation function is activated if phase amplitude is not addressing desired levels.

## 1.3 Product characteristics

### 1.3.1 Absolute maximum ratings

**Table 2. Absolute maximum ratings**

Symbol	Parameter	Notes	Min.	Typ.	Max.	Unit
V <sub>BLD</sub>	Transient supply voltage (load dump) t < 400 ms				V <sub>cl</sub>	V
I <sub>Bond</sub>	DC pin current on EXC, B+, GND (bonding limitation)				15	A
ESD <sub>HBM</sub>	ESD HBM (All pins vs.GND) R=1.5kΩ, C=100pF, RT=25°C		-8		8	kV
ESD <sub>CDM</sub>	ESD CDM on EXC and PH pins		-750		750	V
ESD <sub>CDM</sub>	ESD CDM on B+ and LIN pins		-500		500	V

### 1.3.2 Internal clamping structure

**Table 3. Internal clamping structure**

Symbol	Parameter	Notes	Min.	Typ.	Max.	Unit
V <sub>cl</sub>	Internal central clamp voltage	B+ current injected I=20mA	58		64	V
V <sub>cl_LIN</sub>	Dedicated Clamp to LIN pin	Current injected in LIN pin I=20mA	40		-	V

### 1.3.3 PIN number - absolute maximum ratings - operative range

**Table 4. PIN number - absolute maximum ratings - operative range**

n.	Pin	ABS max rating		operative range		Unit
		Min.	Max.	Min.	Max.	
1	EXC	- 2	B+	- 1.6	B+	V
2	B +	-0.3 <sup>(1)</sup>	V <sub>cl</sub> <sup>(3)</sup>	6	18	V
3	GND	-	-	-	-	
4	LIN	-27 <sup>(2),(3)</sup>	V <sub>cl_LIN</sub>	- 3	18	V
5	PH	-27 <sup>(2)</sup>	V <sub>cl</sub>	- 3	18	V

- 3.2 V, transient 5 s.
- Value at cold temperature: -25 V.
- LIN and B+ AMR not valid at the same time.

### 1.3.4 Thermal data

**Table 5. Thermal data**

Symbol	Parameter	Notes	Min.	Typ.	Max.	Unit
R <sub>th_j-case</sub>	Thermal resistance junction-to-case	Related to TO220			2	°C/W

Symbol	Parameter	Notes	Min.	Typ.	Max.	Unit
Tsd,1	Thermal shutdown threshold	Temperature to disable EXC driver for chip protection (set by THERMAL_TH_SEL)	170	180	190	°C
Tsd,2			165	175	185	°C
Tsd,3			175	185	195	°C
Tsd,4			180	190	200	°C
Tsdhy	Thermal shut-down hysteresis	EXC from OFF STATE (due to thermal shutdown) to ON STATE	2	6	10	°C
Temp_R	Tj for full functional and full spec		-40		150	°C
Temp_F	Tj for full functional with parameters deviation		150		190	°C
Temp_SRctrl	Current SR disable temperature	Tj over which EXC current slew rate control is disabled (SR_HT_DIS)	125	135	145	°C
Temp_SRctrl_hist	Temp_SRctrl hysteresis	Hysteresis from "disabled" state (entered because Tj>Temp_SRctrl) to "enabled" state		6		°C
Tstg, Tcase	Storage and case temperature range		-40		150	°C

## 2 Package information

In order to meet environmental requirements, ST offers these devices in different grades of **ECOPACK** packages, depending on their level of environmental compliance. ECOPACK specifications, grade definitions and product status are available at: [www.st.com](http://www.st.com). ECOPACK is an ST trademark.

### 2.1 PENTAWATT In Line package information

Figure 3. PENTAWATT In Line package outline

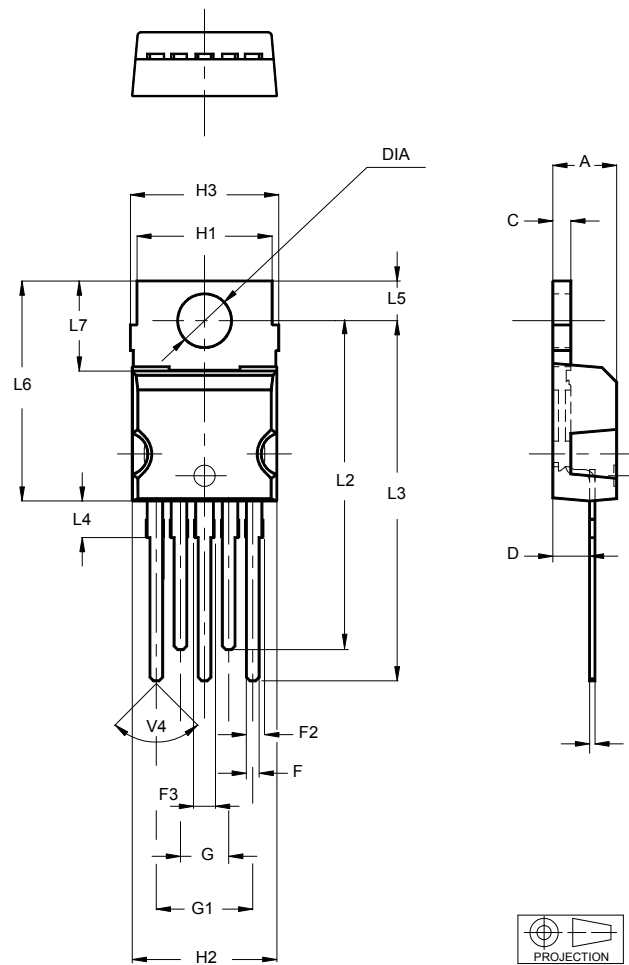

Table 6. PENTAWATT In-Line package mechanical data

Symbol	Dimensions mm		
	Min.	Typ.	Max.
A	4.30		4.80
C	1.17		1.37
D	2.40		2.80
E	0.35		0.55
F	0.80		1.05
F	0.80		0.96

Symbol	Dimensions mm		
	Min.	Typ.	Max.
F2	1.10		1.40
F3	1.25		1.55
G	3.20		3.60
G1	6.60		7.0
H1	9.30		9.70
H2			10.40
H3	10.05		10.40
L2	23.05		23.80
L3	25.30		26.10
L4	0.90		2.90
L5	2.60		3.0
L6	15.10		15.80
L7	6.0		6.60
V4		90°	
Dia	3.65		3.85

## 2.2 Bare die

Die dimension, pads dimension and position will be provided on demand

## Revision history

**Table 7. Document revision history**

Date	Version	Changes
11-Jun-2019	1	Initial release.



## Contents

<b>1</b>	<b>Functional description</b>	<b>2</b>
1.1	External component required	2
1.2	Pin description	3
1.2.1	EXC	3
1.2.2	B+	3
1.2.3	GND	3
1.2.4	LIN	3
1.2.5	PH	3
1.3	Product characteristics	4
1.3.1	Absolute maximum ratings	4
1.3.2	Internal clamping structure	4
1.3.3	PIN number - absolute maximum ratings - operative range	4
1.3.4	Thermal data	4
<b>2</b>	<b>Package information</b>	<b>6</b>
2.1	PENTAWATT In Line package information	6
2.2	Bare die	7
	<b>Revision history</b>	<b>8</b>

**IMPORTANT NOTICE – PLEASE READ CAREFULLY**

STMicroelectronics NV and its subsidiaries (“ST”) reserve the right to make changes, corrections, enhancements, modifications, and improvements to ST products and/or to this document at any time without notice. Purchasers should obtain the latest relevant information on ST products before placing orders. ST products are sold pursuant to ST’s terms and conditions of sale in place at the time of order acknowledgement.

Purchasers are solely responsible for the choice, selection, and use of ST products and ST assumes no liability for application assistance or the design of Purchasers’ products.

No license, express or implied, to any intellectual property right is granted by ST herein.

Resale of ST products with provisions different from the information set forth herein shall void any warranty granted by ST for such product.

ST and the ST logo are trademarks of ST. For additional information about ST trademarks, please refer to [www.st.com/trademarks](http://www.st.com/trademarks). All other product or service names are the property of their respective owners.

Information in this document supersedes and replaces information previously supplied in any prior versions of this document.

© 2019 STMicroelectronics – All rights reserved