

PQ6CU12X2APQ

CMOS Step-up
Chopper Regulator

■ Features

- 1.High switching voltage :MAX.40V
- 2.Switching current: 250mA
- 3.Oscillation frequency variable: 300 to 800 kHz
- 4.Small package (2.9×2.8×1.3mm)
- 5.Possible to use ceramic capacitor
- 6.Built-in overcurrent protection functions
- 7.RoHS directive compliant

■ Applications

- 1.Power supply for tuner of digital AV equipment
- 2.LCD monitors

■ Absolute Maximum Ratings

(Ta=25°C)

Parameter	Symbol	Rating	Unit
Input voltage	V _{IN}	6.5	V
Switching voltage	V _{SW}	40	V
ON/OFF control voltage	V _C	V _{IN}	V
OSC voltage	V _C	V _{IN}	V
Feed back voltage	FB	V _{IN}	V
Switching current	I _{SW}	250	mA
Power dissipation	P _d	350	mW
Junction temperature	T _j	150	°C
Operating temperature	T _{opr}	-40 to +85	°C
Storage temperature	T _{stg}	-40 to +150	°C
Soldering temperature	T _{sol}	260(10s)	°C

■ Operating conditions

Parameter	Symbol	Rating	Unit
Operating Junction temperature	T _j	-40 to +125	°C

■ Outline Dimensions

(Unit:mm)

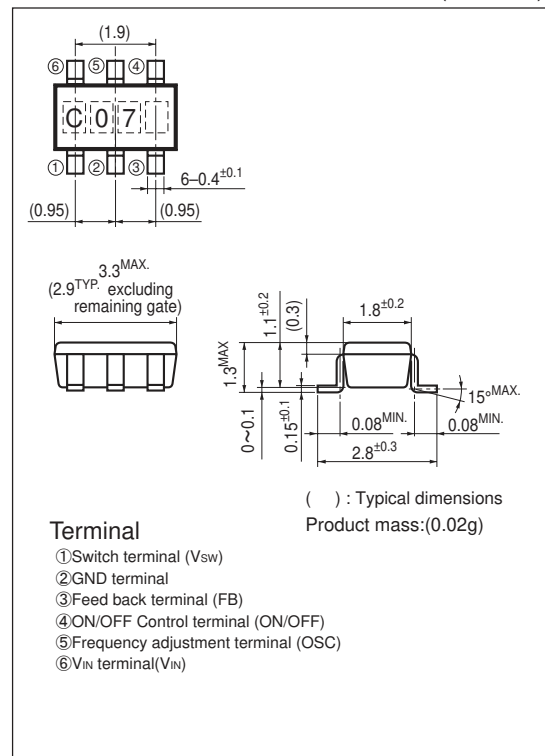

Terminal

- ① Switch terminal (V_{sw})
- ② GND terminal
- ③ Feed back terminal (FB)
- ④ ON/OFF Control terminal (ON/OFF)
- ⑤ Frequency adjustment terminal (OSC)
- ⑥ V_{IN} terminal(V_{IN})

Lead finish:Lead-free solder plating
(Composition: Sn2Bi)

Notice The content of data sheet is subject to change without prior notice.

In the absence of confirmation by device specification sheets, SHARP takes no responsibility for any defects that may occur in equipment using any SHARP devices shown in catalogs, data books, etc. Contact SHARP in order to obtain the latest device specification sheets before using any SHARP device.

Electrical Characteristics

(Unless otherwise specified, condition shall be $V_{IN}=V_C=5V, V_O=30V, I_O=10mA, f_o=500kHz, T_a=25^\circ C$)

Parameter	Symbol	Conditions	MIN.	TYP.	MAX.	Unit
Input-output voltage range	V_{IN}	-	3	-	5.5	V
Quiescent current	I_q	Switching, $I_O=0mA$	-	0.8	1.8	mA
Stand-by current	I_{SD}	$V_C=0V$	-	0.1	1	μA
Error amplifier						
Reference voltage	V_{REF}	-	0.97	1	1.03	V
Line regulation	$ R_{egL} $	$V_{IN}=4$ to $5.5V, I_O=5mA$	-	0.7	3	%
Load regulation	$ R_{egL} $	$I_O=1$ to $15mA$	-	1	3	%
Oscillator						
Oscillation frequency range	$f_o(\text{range})$	-	300	-	800	kHz
Oscillation frequency	f_o	$R_{osc}=130k\Omega$	375	500	625	kHz
Maximum duty	D_{MAX}	-	90	-	-	%
Power switch						
Overcurrent detection level	I_L	Switching current peak	260	-	-	mA
On-resistance	R_{ON}	$I_{SW}=150mA$	-	1.7	2.5	Ω
Leakage current	I_{LEAK}	$V_{SW}=40V$	-	0.01	1	μA
ON/OFF control terminal						
ON-state voltage for control	$V_{C(ON)}$	-	1	-	-	V
OFF-state voltage for control	$V_{C(OFF)}$	-	-	-	0.4	V
ON-state current for control	$I_{C(ON)}$	-	-	-	100	μA

Fig.1 Standard measuring circuit

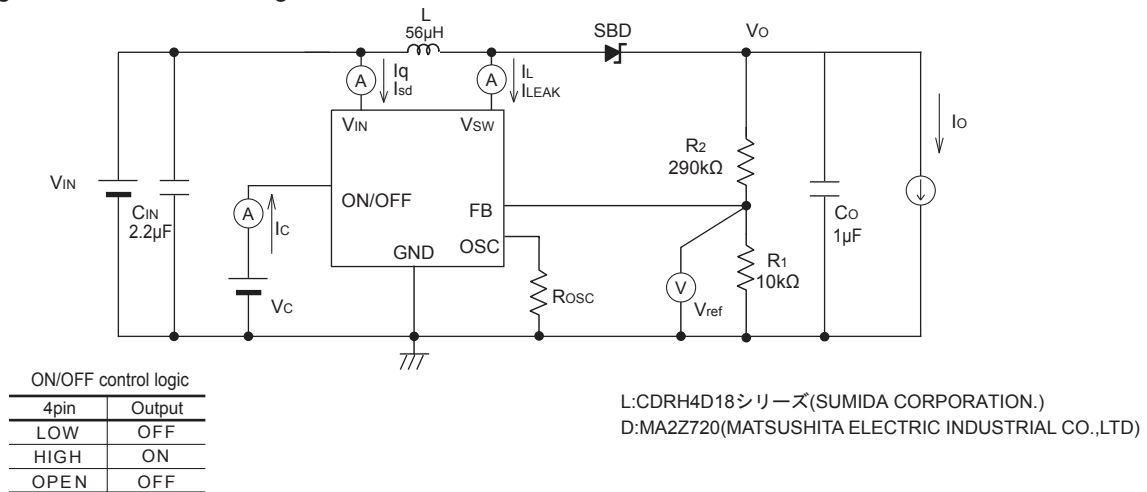

Fig.2 Power Dissipation vs. Ambient Temperature

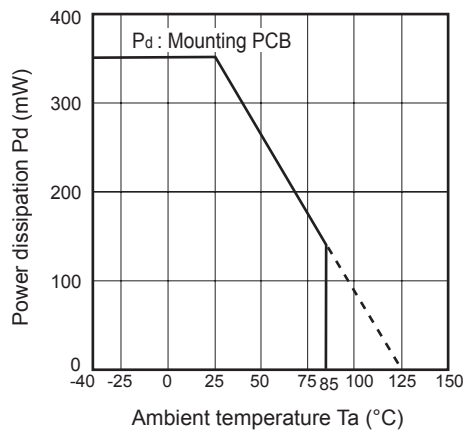

Fig.3 Reference Voltage Fluctuation vs. Junction Temperature

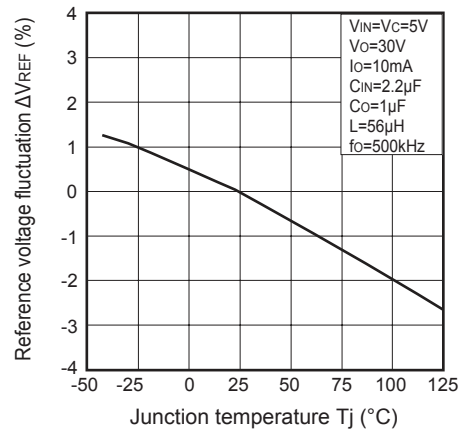

Fig.4 Oscillation Frequency Fluctuation vs. Junction Temperature

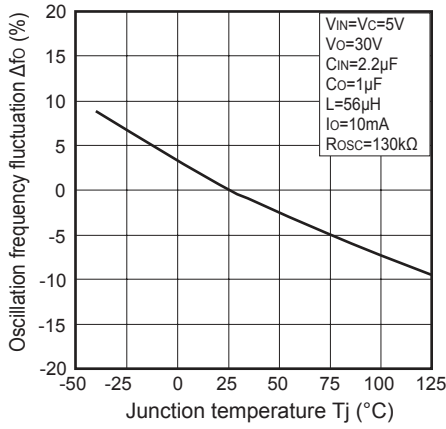

Fig.5 Oscillation Frequency vs. Resistance (Rosc)

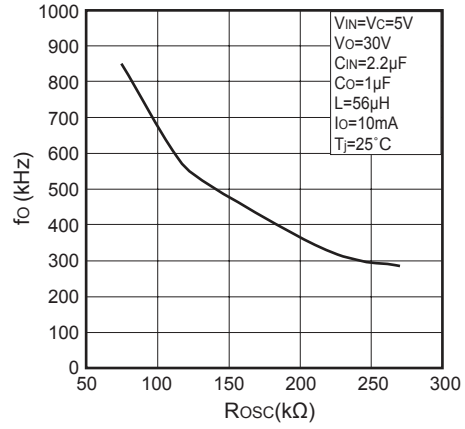

Fig.6 On-resistance vs. Junction Temperature

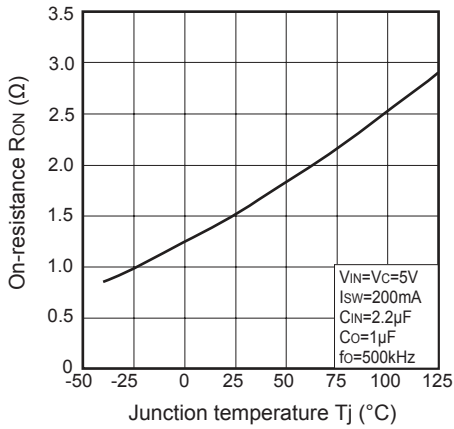

Fig.7 ON-state Voltage for Control vs. Junction Temperature

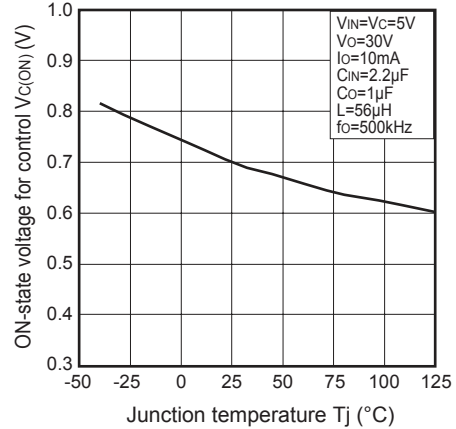
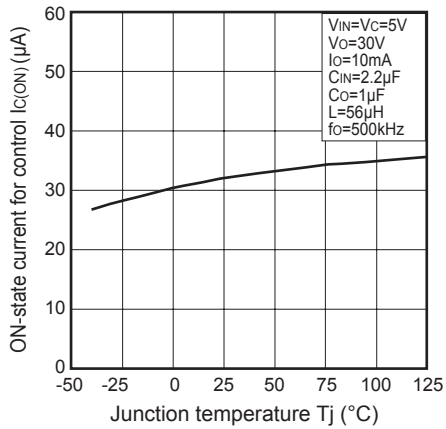
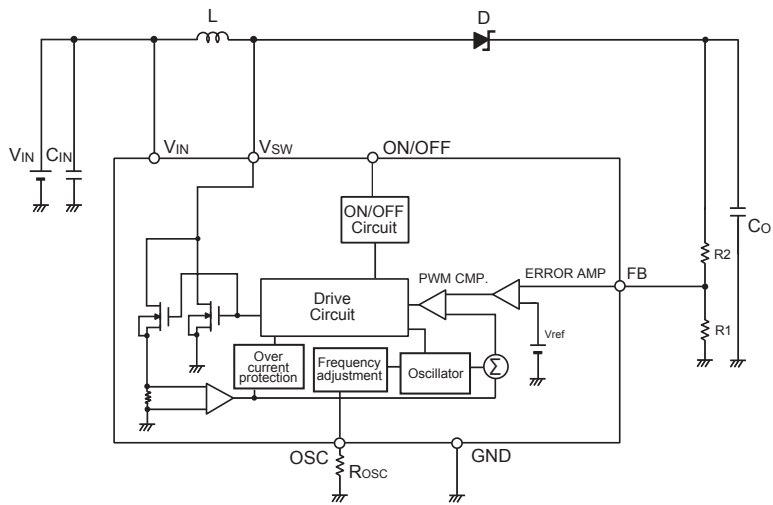

Fig.8 ON-state Current for Control vs. Junction Temperature



■ Block Diagram



■ Example of application

