

REV.	DATE	ECR NO.	DESCRIPTION
NC	07/02/10	XXXXXX	INITIAL RELEASE

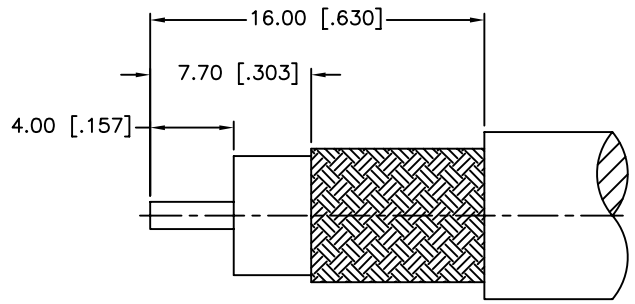

RECOMMENDED
CABLE STRIPPING DIM'S

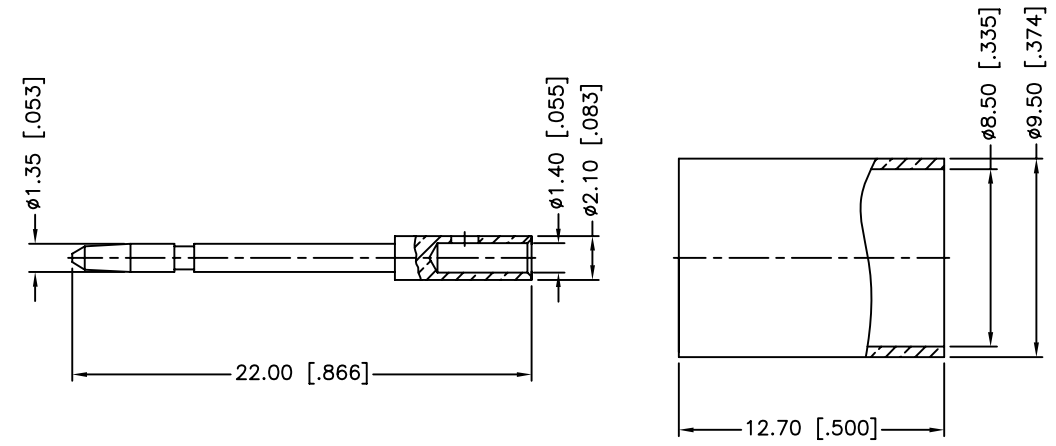
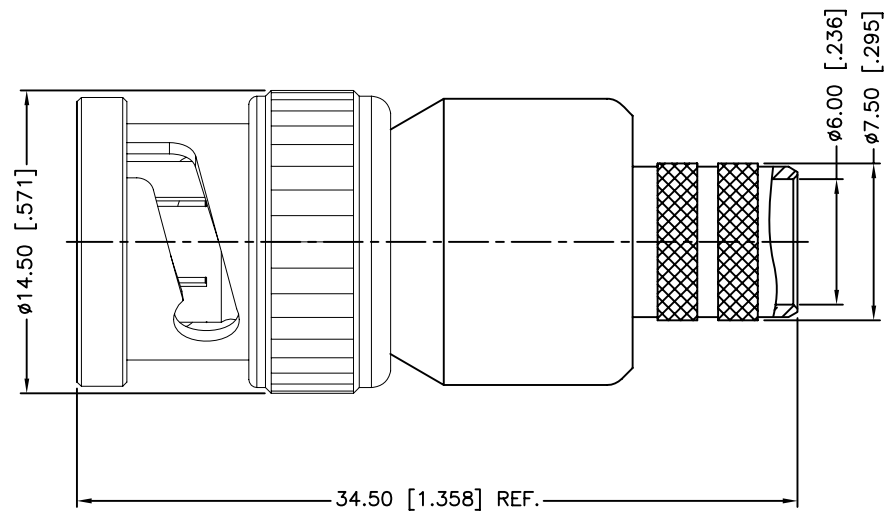

1. CRIMPED FERRULE
HEX CRIMP SIZE .324"
2. CRIMPED CONTACT PIN
HEX CRIMP SIZE .068"

10	FERRULE	BRASS	NICKEL	1
9	CONTACT PIN	BRASS	GOLD	1
8	WASHER	BRASS	NICKEL	1
7	SPRING	SK5	NICKEL	1
6	RETAINER RING	BRASS	NICKEL	1
5	GASKET	RUBBER	RED	1
4	BARREL	BRASS	NICKEL	1
3	INSULATOR	PTFE	NATURAL	1
2	SHELL	BRASS	NICKEL	1
1	BODY	BRASS	NICKEL	1
	DESCRIPTION	MATERIAL	FINISH	QTY

UNLESS OTHERWISE SPECIFIED DIMENSIONS ARE IN MILLIMETERS. DIMENSIONS IN [] ARE IN INCHES AND FOR CUSTOMER REFERENCE ONLY.

UNLESS OTHERWISE SPECIFIED TOLERANCES FOR MILLIMETERS ARE:
0.5 - 8mm ± 0.20mm
8 - 30mm ± 0.40mm
30 - 120mm ± 0.50mm

UNLESS OTHERWISE SPECIFIED TOLERANCES FOR INCHES ARE:
.020 - .315 ± 0.007"
.315 - 1.180 ± 0.015"
1.180 - 4.724 ± 0.020"

DO NOT SCALE DRAWING

APPROVALS	DATE
DRAWN M.ZHANG	07/02/10
CHECKED	
ISSUED	
SHEET 1 OF 1	
CAD FILE	C:/CONNEX/112981.DWG

Amphenol Connex

PART DESCRIPTION
**BNC CRIMP PLUG (FOR BELDEN 1794A,
7855A, GEPCO VHD 7000 CABLE)**

PART NO. **112981**

DWG. NO. 112981.DWG REV. NC SIZE A SCALE NA