

Finished Products Inspection Report	Eason Tech Industrial Co., Ltd.	
		CageNuts 10-32

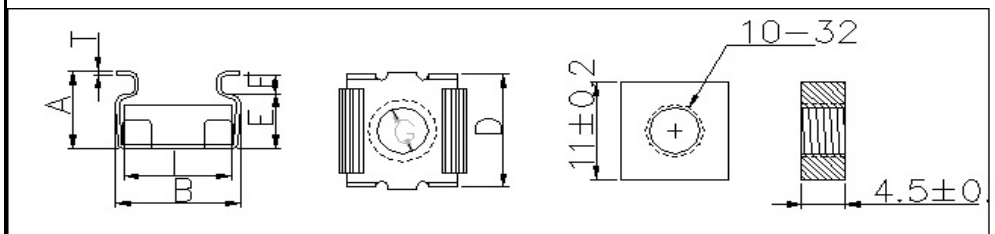

A	9.70±0.5
B	12.9±0.5
D	12.80±0.5
E	6.70±0.2
F	3.00±0.2
G	7.00±0.1
I	11.20±0.5
T	0.50±0.04
CageHRC38-42	

1. Cage 50C NutSAF1010

Small technical drawing of a cage nut assembly with a bolt and nut, labeled 10-32.

NOTES:

- 1) Screw Material: Low Carbon Steel
- 2) Screw Finish: Black Oxide
- 3) Washer Material: Black Nylon 6/6
- 4) Washer Outside Diameter: 0.429"-0.439"
- 5) Washer Thickness: 0.030"-0.040"
- 6) Must Be Heat Treated To ANSI B18.6.3 Spec
- 7) Must Be RoHS And Reach Compliant

REV	DESCRIPTION	DATE	DRAWN	CHECKED

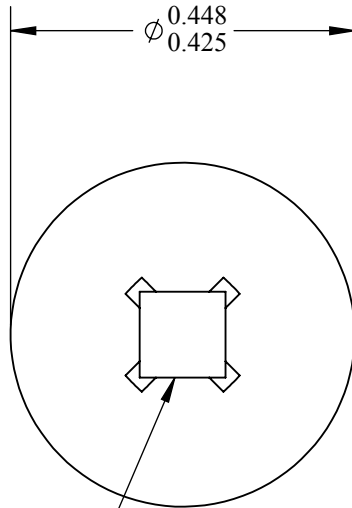
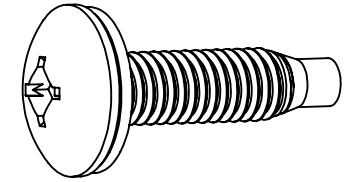

#2R Type-III Square Recess
Penetration Gaging Depth: 0.060"-0.075"
#2 Type-I Phillips Cross Recess
Penetration Gaging Depth: 0.070"-0.093"

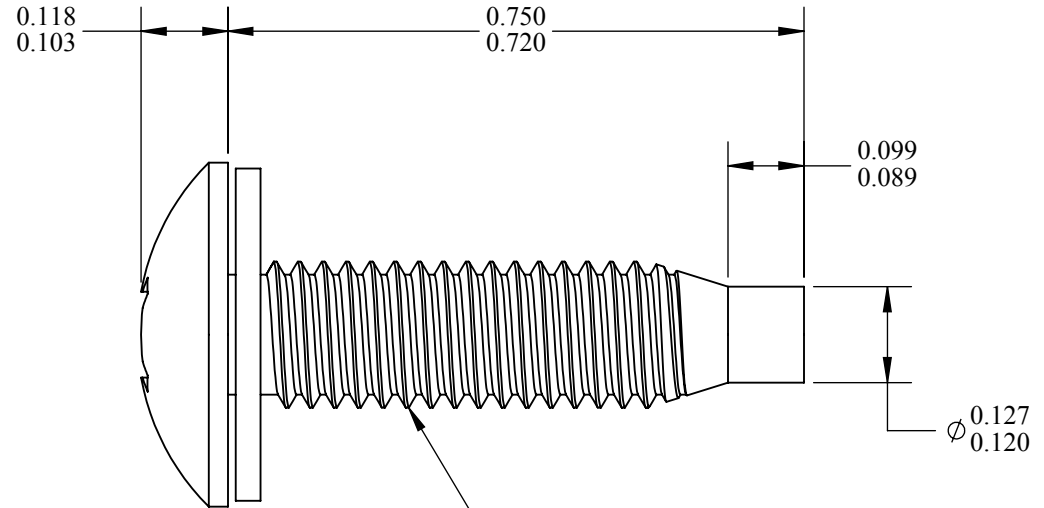

CUSTOMER SIGNATURE REQUIRED

NAME		DATE		INTERPRET GEOMETRIC TOLERANCING PER:		TITLE:		 a WOLSELEY Industrial Group company				
ENDRIES DRAWN	JJW	8/28/15	8/28/15	UNLESS OTHERWISE SPECIFIED: DIMENSIONS ARE IN INCHES TOLERANCES: FRACTIONAL ± ANGULAR: MACH ± BEND ± TWO PLACE DECIMAL ± THREE PLACE DECIMAL ±		10-32x3/4" Quadrex Truss Head Machine Screw Full Dog Point With Captive Flat Washer						
ENDRIES CHECKED	KDB	8/28/15		PROPRIETARY AND CONFIDENTIAL THE INFORMATION CONTAINED IN THIS DRAWING IS THE SOLE PROPERTY OF ENDRIES INTERNATIONAL. ANY REPRODUCTION IN PART OR AS A WHOLE WITHOUT THE PERMISSION OF ENDRIES INTERNATIONAL IS PROHIBITED.		MATERIAL		FINISH				
CUSTOMER SIGNATURE:						See Notes		See Notes		ENDRIES PART NUMBER:	DRAWING NUMBER:	SIZE
				DO NOT SCALE DRAWING		SHEET: 1 of 1		UNSPECIFIED DIMENSIONS AND TOLERANCES PER:		SCS19544QUAD		REV
						ASME B18.6.3				WEIGHT:		SCALE:4:1