

Instruction Manual for Evaluation Board of TB67S261FTG

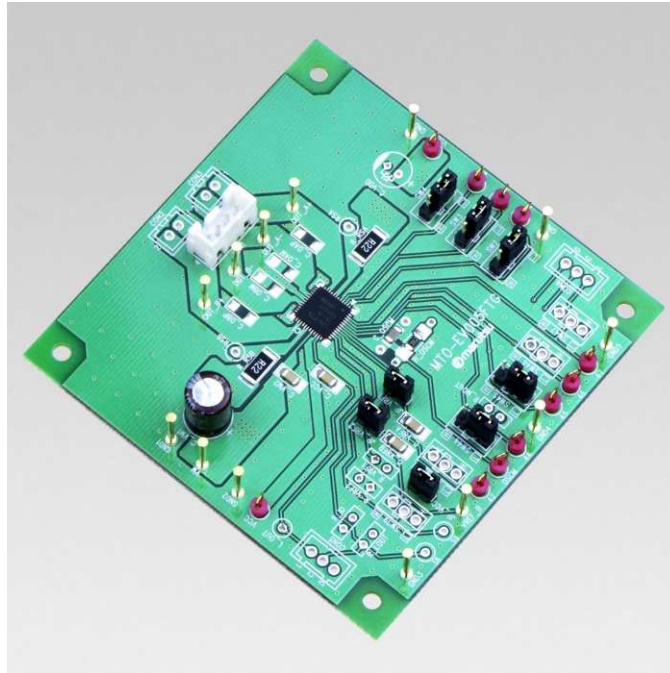

12th Sep. 2018

Rev.1.0

Product Outline

The TB67S261FTG is a motor driver for 2-phase bipolar type stepping motor with a PWM chopping and PHASE-in control system.

By adopting BiCD process, maximum Output withstand voltage of 50V and maximum Output current of 2.0A as absolute maximum ratings are realized.

Owing to this evaluation board, it is possible to try each excitation operation of 2 phase, 1-2 phase, W1-2 phase with PWM constant current drive.

In addition, Toshiba's new advanced technology of ADMD (Advanced Dynamic Mixed Decay) is equipped in this IC. By monitoring current decay situation inside the IC and optimizing choice of Fast Decay and Slow Decay automatically, ADMD provides improved current followability at higher speed rotation than the conventional system, ADMD realizes motor control with high efficiency/low noise at high speed rotation.

【Note】

In using this device, please be careful about the thermal condition sufficiently. And for detailed operations such as control input, please refer to the datasheet and the application notes by accessing to the following URL.

<https://toshiba.semicon-storage.com/ap-en/product/linear/motordriver/detail.TB67S261FTG.html>

Further, use of this evaluation board is strictly limited to the purpose of evaluating and learning the motor control. Please do not ship it to market.

Basic Notes in use of this evaluation board



Power Supply Voltage and Operating Range

In using the TB67S261FTG, the voltage should be applied to the VM, VREFA, and VREFB pins.

The absolute maximum rating of VM (Power supply voltage for motor) is 50V, but operating range of the power supply is 10 to 47V.

The absolute maximum rating of Vref (Reference Voltage for setting motor current) is 5V, but operating range of this voltage is 0 to 3.6V.

Power Supply Sequence

In applying power supplies and shutting those down, no special procedures is required, because the TB67S261FTG incorporates a error detection circuit of power-on reset (POR).

The threshold voltage of POR is designed as $VM=8.0V\pm 1.0V$.

However, under unstable state of VM as raising and falling, it is recommended to turn off the motor operation. Please start operation of motor by input signals after the power supplies become stable state.

Motor Current (Output Current)

Motor current should not exceed the specified Output Current (2.0A or less).

Also, please note that the maximum current may be limited due to usage conditions (ambient temperature, heat issue, step resolution setting, etc.).

Please set to the optimum value after thermal circulation and actual evaluation under operating environment .

Control Input

Before applying Power supplies, it is recommended that Input signals (INA1, INA2, PHASEA, INB1, INB2, PHASEB, STANDB) are set to Low level. But even if the logic signal is inputted when VM voltage is not applied, electromotive force does not generate.

Explanation of Each Abnormality Detection Circuit

TSD (Thermal Shut Down)

When the junction temperature (T_j) of this chip exceeds 160°C (typ.), a internal detection circuit starts operation and all outputs are turned off. And a dead time is set inside this IC in order to avoid malfunction caused by switching etc..

In the operating state of TSD, IC stays stop mode.

After TSD operation, this is canceled by turning the power supply on again or setting to standby mode once by the DMODE pin and then releasing it.

The TSD functions when the IC abnormally heats up. So that please avoid utilizing this function actively.

ISD (Over Current Detection)

When any of current which flows in output transistors exceeds 3.0A (typ.), a internal detection circuit starts operation and turns off all output transistors. And a dead time is set inside this IC in order to avoid malfunction caused by switching etc..

In the operating state of ISD, IC stays stop mode.

After ISD operation, this is canceled by turning the power supply on again or setting to standby mode once by the DMODE pin and then releasing it.

* Those above values in each detection circuit are not guaranteed but reference ones.

Connection of Evaluation Board

Corresponding table of Silk name and Signal name

Please note that the names of silk and signal on this board are different each other as follows, because this board is designed and developed as a unfired one for H-Bridge series.

Silk name	Signal name
L_OUT	NC
38	NC
39	NC
VREFB	VREFB
42	VREFA
OSCM	OSCM
44	INA1
45	INA2
46	PHASEA
47	PHASEB
2	IN_B1
3	IN_B2
4	STANDBY

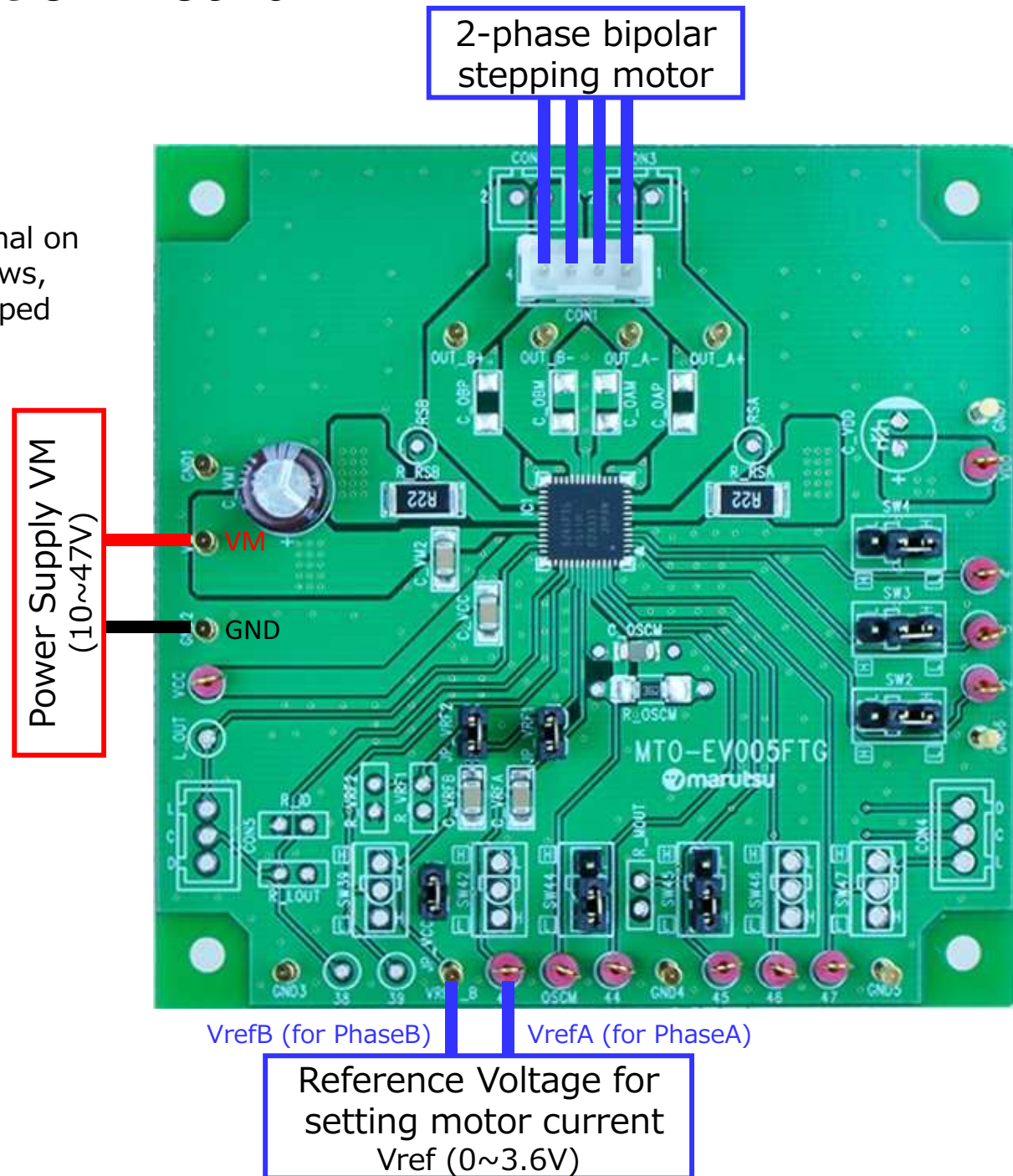

Setting Evaluation Board : 1

Setting Motor Current

The TB67S261FTG conducts motor operation by PWM constant current control which is based on the frequency of the OSCM oscillation circuit. The maximum current value (set Motor current value) can be determined by a sense resistor (RRS) and the reference voltage (Vref).

Formula of setting Motor Current Value

$$I_{out(max)} = V_{ref(gain)} \times \frac{V_{ref}(V)}{R_{RS}(\Omega)}$$

Vref(gain): damping ratio of Vref is 1/5.0(typ.)
This board is set to RRS=0.22Ω

By using the jumper of JP_VRF1, Vref of A and B channel are unified, and both can be set from the VrefA pin.

And it is also possible to generate a Vref voltage from the built-in regulator of VCC voltage by mounting resistors in R_VRF 1 and R_VRF2, and shorting JP_VRF2 on this board.

However, please note that if more current than the built-in regulator's ability is drawn, VCC regulation may not be maintained. So that please be careful that total of voltage dividing resistors does not become less than 10kΩ.

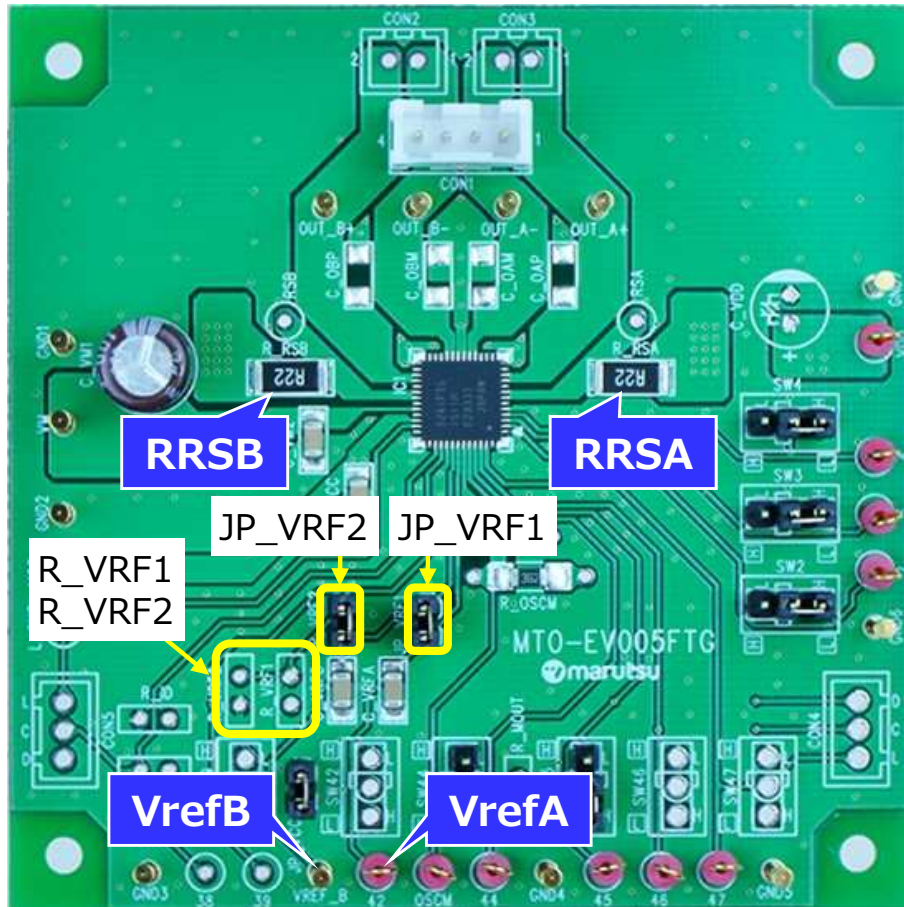

Waveform of Motor Current

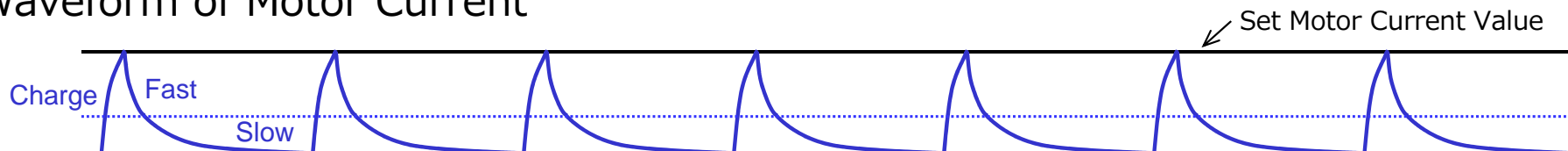

Setting Evaluation Board :2

Setting the Chopping Frequency for constant current PWM control

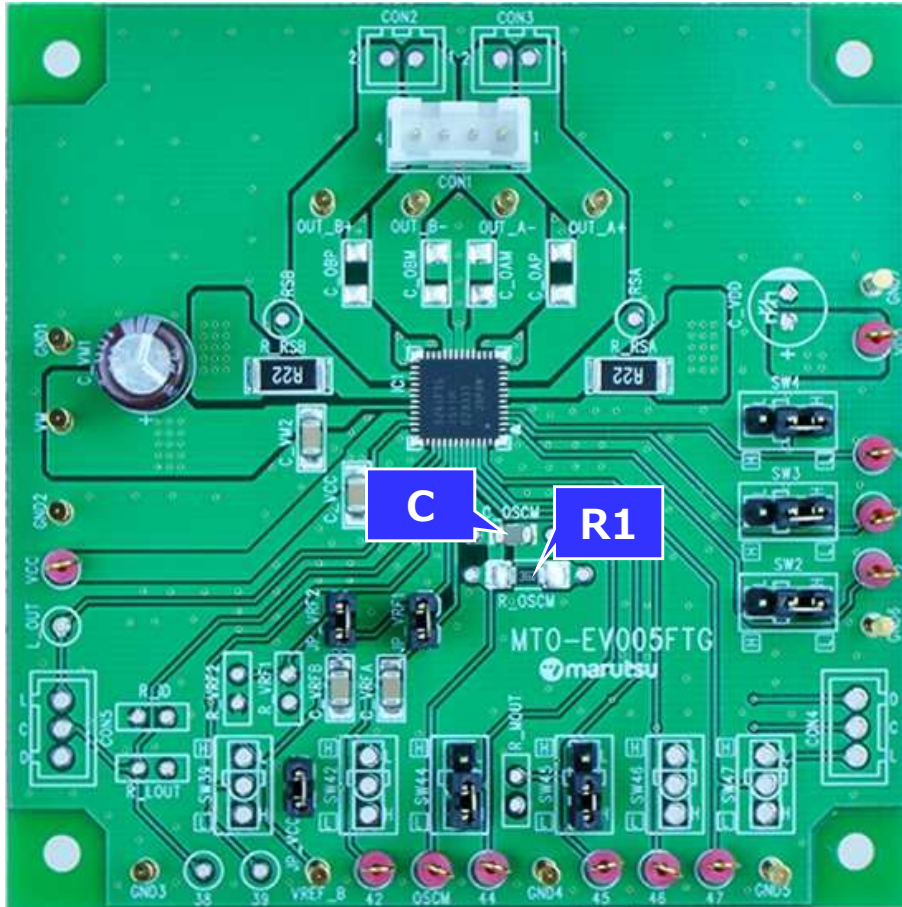

In PWM control of the TB67S261FTG, the internal oscillation frequency (f_{OSCM}) and the chopping frequency (f_{chop}) can be adjusted according to the constant of the external components those are connected to the OSCM pin. In general, f_{chop} is recommended to set in the frequency range of 40kHz to 150kHz.

Formula of Chopping Frequency

$$f_{OSCM} = 1 / [0.56 \times \{C \times (R1 + 500)\}]$$

$$f_{chop} = f_{OSCM} / 16$$

This board is set to 100kHz by mounting $C=270\text{pF}$ and $R1=3.6\text{k}\Omega$.

Waveform of Motor Current

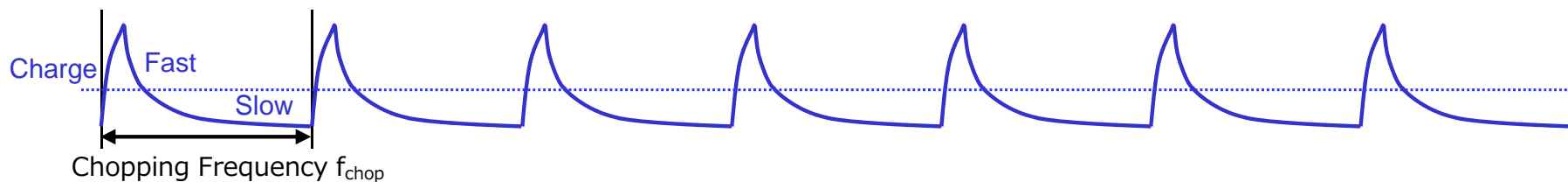

Setting Evaluation Board :3

Setting for Motor Operation

【Enlarged view of the jumper section】

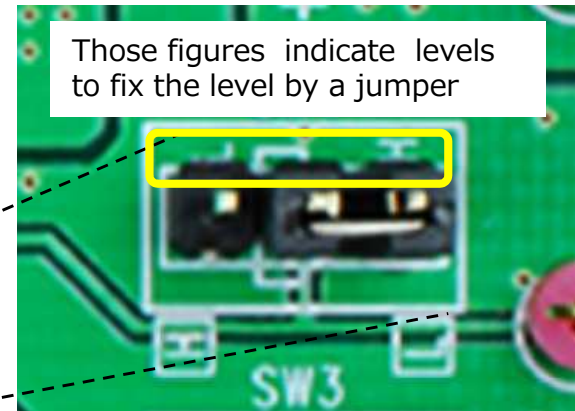
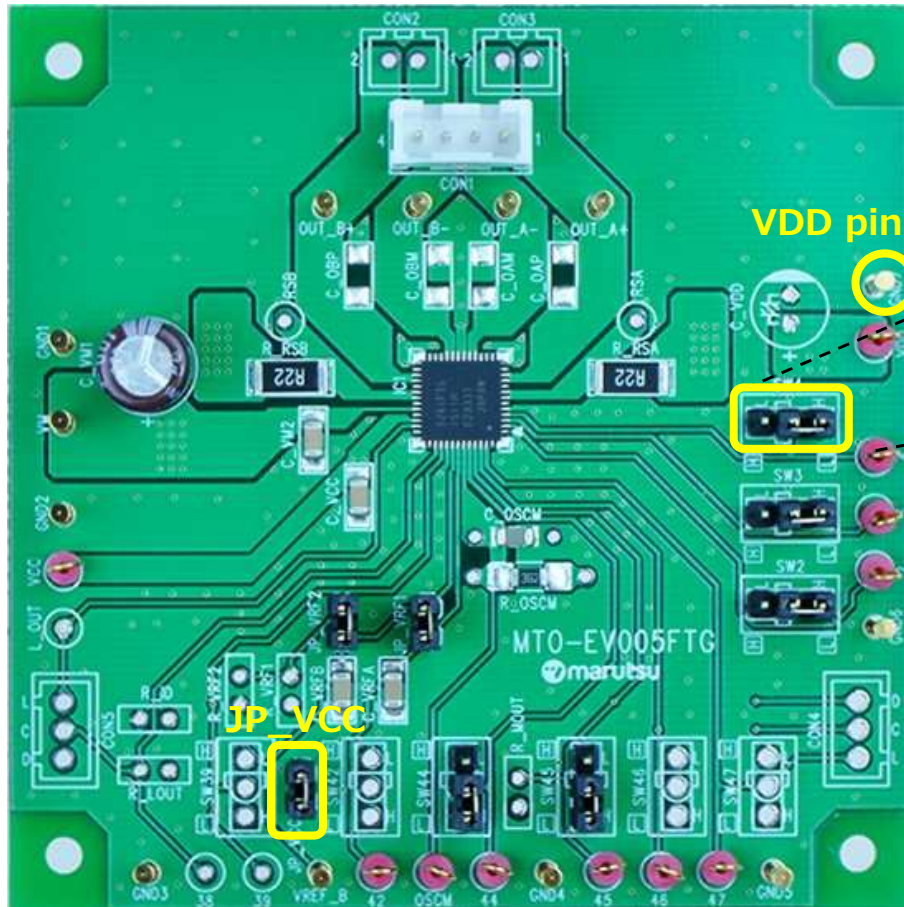

On this evaluation board, jumpers as shown in the picture above are provided for setting operation of TB67S261FTG

When selecting functions by using jumpers, please short the JP_VCC, or supply high level from the VDD pin.

The characters surrounded by white square frame close to the jumpers show the Level (H/L). Please change the position of jumpers in accordance with the function setting to be used.

Further when inputting signals from the outside, please remove the short pins.

Circuit of Evaluation Board

