

THIS DRAWING IS UNPUBLISHED. RELEASED FOR PUBLICATION 2011  
 © COPYRIGHT 2011 Tyco Electronics AMP GmbH ALL RIGHTS RESERVED.

LOC	DIST	REVISIONS			
P	LTR	DESCRIPTION	DATE	DWN	APVD
A1	-	REVISIED PER ECR-13-005967	08APR2013	UR	SB
A2	-	ECR-14-009313	20JUN2014	MB	SB
B	-	ECR-15-001891	13OCT2014	MB	UR
C	-	ECR-16-001965	20FEB2016	GK	KL

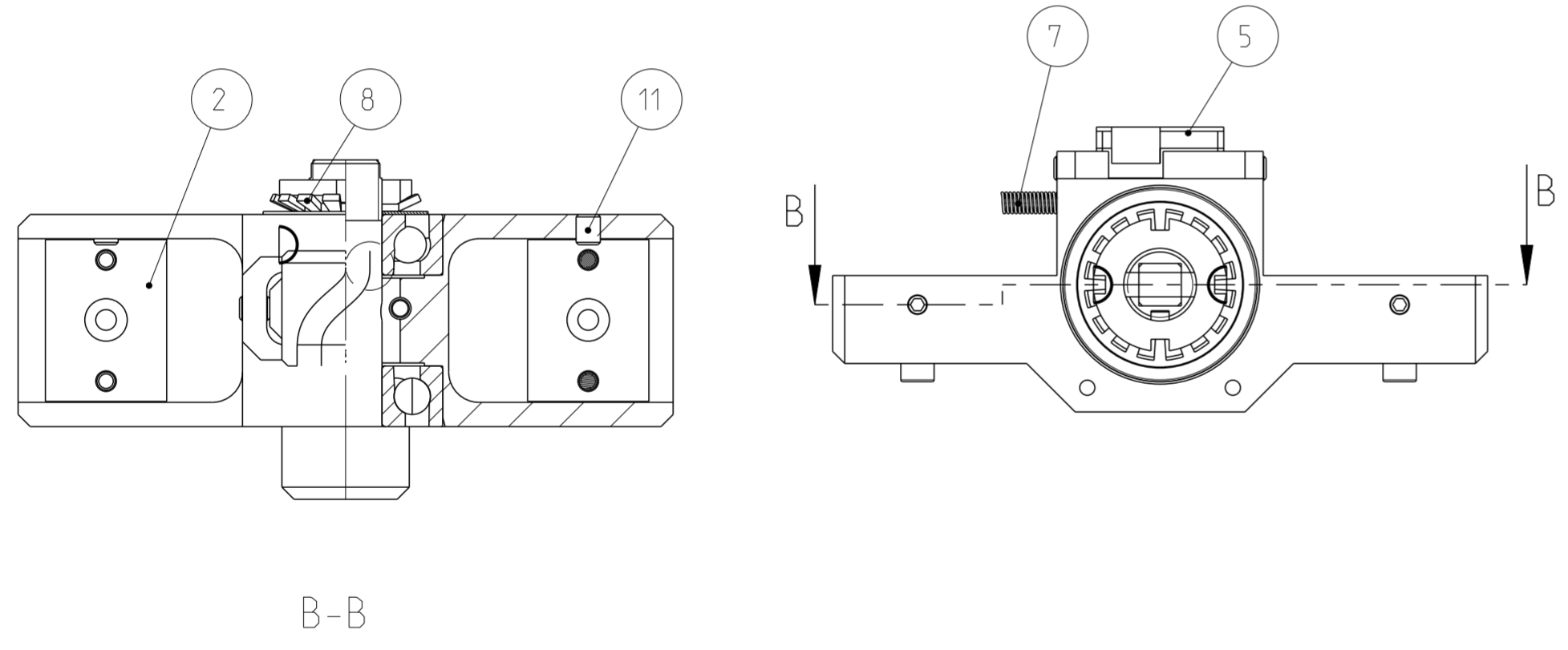
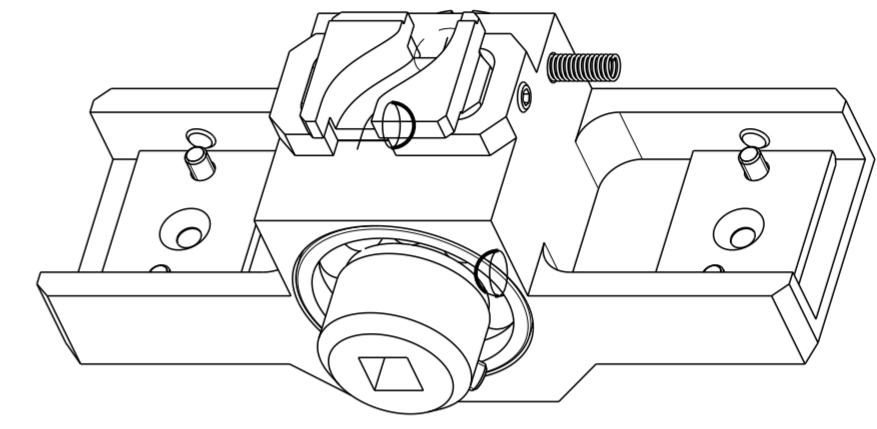
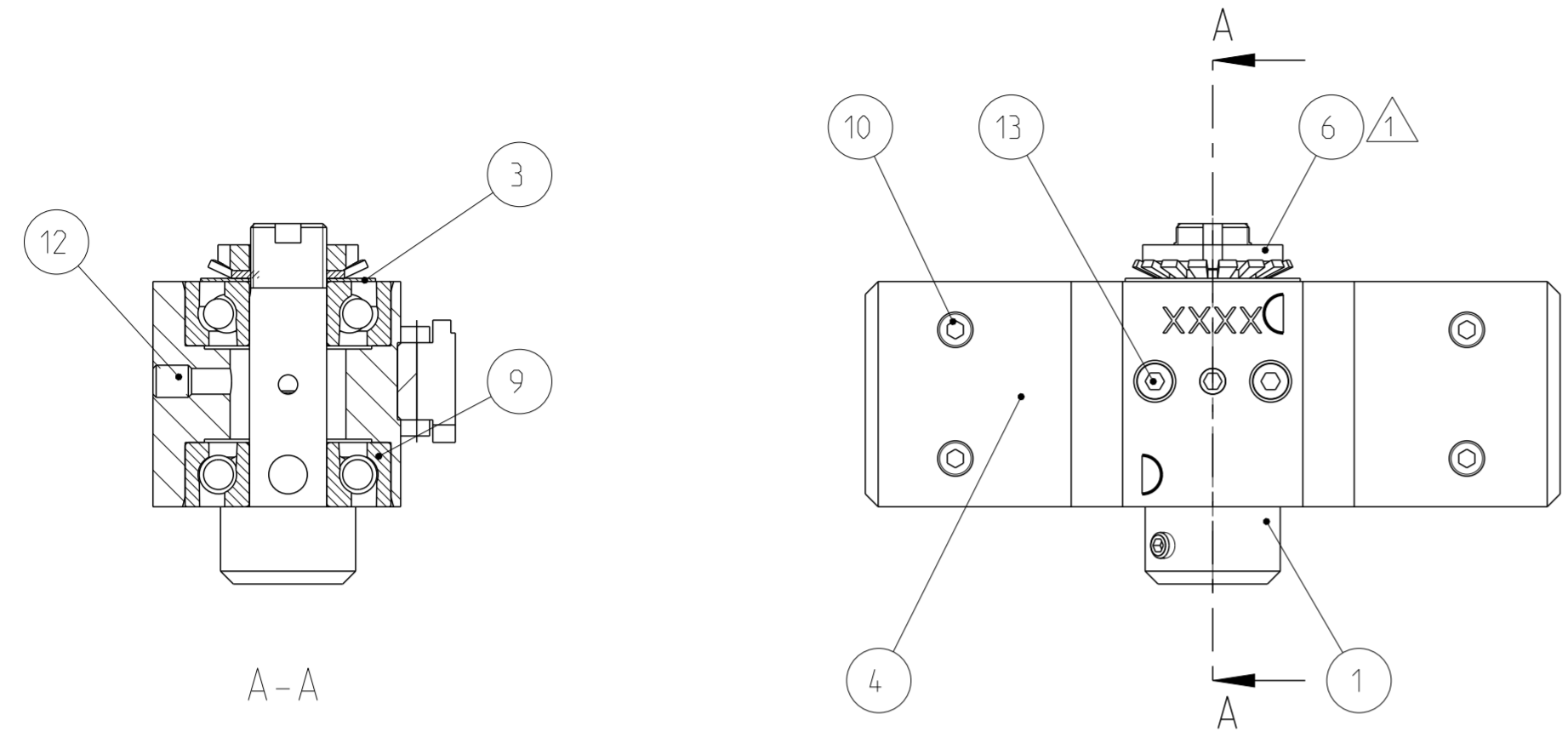

1 Lagerspiel bei Montage abstimmen  
 Bearing clearance adjusted while mounting

POS	QTY	TE/PN	PART REV	DESCRIPTION	WEAR	SPARE
1	1	3-539480-1	F	FINGER SHAFT -	-	-
2	2	3-539485-7_EU	D1	ABSTIMMPLATTE ADJUSTMENT BLOCK	-	-
3	1	5-1372295-2_EU	B	Scheibe washer	-	YES
4	1	6-539939-4_EU	F	LAGERGEHAUSE BEARING HOUSING	-	-
5	1	6-1372362-1	A	KULISSE SLOTTED PIECE	-	-
6	1	1-516148-7	A	SHAFT NUT -	-	YES
7	1	5-659650-0	A	COMPRESSION SPRING -	-	YES
8	1	516149-4	A	LOCK PLATE -	-	YES
9	2	516343-4	A	BEARING, d/D/B:12/32/10	-	YES
10	4	1-519000-3_GATD_DKB	A1	Zylinderschr. M3x10 DIN 912 SCREW DIN EN ISO 4762	-	YES
11	4	2-519011-8	B	SCREW M4x5 DIN 913 -	-	YES
12	1	3-519011-6	B	SCREW M5x6 DIN 913 -	-	YES
13	2	519072-6	A4	Zylinderschraube DIN 912 M3*40 DIN 912	-	YES

THIS DRAWING IS A CONTROLLED DOCUMENT.		DWN RAGHAVENDRA 01DEC2011	<b>STE</b> TE Connectivity	
DIMENSIONS: mm		CHK KURT L 01DEC2011		
TOLERANCES UNLESS OTHERWISE SPECIFIED:		APVD SIEGRIED B 01DEC2011	NAME BEARING RAM ASSEMBLY Lagerung Kontaktfinger	
0 PLC ±		PRODUCT SPEC	SIZE CAGE CODE DRAWING NO RESTRICTED TO	
1 PLC ±		APPLICATION SPEC	A2 00779 C-539574-9	
2 PLC ±		WEIGHT	SCALE 1:1 SHEET 1 OF 1 REV C	
3 PLC ±		MATERIAL		
4 PLC ±		Customer Drawing		
ANGLES ±				
FINISH				