

THIS DRAWING AND THE INFORMATION SET FORTH HERE-  
ON ARE THE PROPERTY OF TYCO ELECTRONICS  
AND ARE TO BE HELD IN TRUST AND CONFIDENCE. PUB-  
LICATION, DUPLICATION, DISCLOSURE, OR USE FOR ANY  
PURPOSE NOT EXPRESSLY AUTHORIZED IN WRITING BY  
TYCO ELECTRONICS IS PROHIBITED.

REVISIONS

LTR	DESCRIPTION	DATE	APPROVED
A	RELEASED PER ECO-11-025206	12/16/11	B. WONG

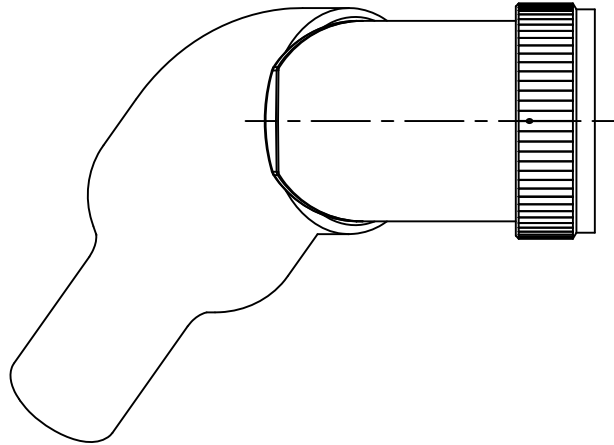

SPIN-LOCK ADAPTER, SHRINKABLE MOLDED PART, SEALED

NOTES:

- THIS PRODUCT IS DESIGNED TO TERMINATE A BRAIDED CABLE SHIELD TO A CONNECTOR AND HEAT SHRINKABLE LIPPED BOOT TO A CONNECTOR.
- SEE DRAWING "TR" FOR DETAIL ON TINEL-LOCK RING. RINGS ARE DESIGNED TO BE HEATED ELECTRICALLY. ALL RINGS ARE MARKED WITH THERMOCHROMIC PAINT WHICH CHANGES COLOR WHEN INSTALLATION TEMPERATURE IS REACHED.
- ADAPTER TO BE PERMANENTLY MARKED WITH CODE IDENT. NO. AND PART NO. LESS RING DESIGNATOR (E.G.: 06090-XXXXXXX-XXXXX).
- ADAPTER MATES TO MIL-C-81703, SERIES III, MS3424, MS3446, MS3464, MS3467, MS3468, CLASS E AND L.
- ADAPTER MATES TO MIL-C-5015G, MS3400 SERIES, CLASS D, E, K, L, U & W; MS3400 MS3401, MS3404, MS3406, MS3450, MS3451, MS3454, MS3456, MS3470, MS3471, MS3472, MS3474, MS3475, MS3476. MIL-C-83723, SERIES II, CLASS A & L. MIL-C-83723, /14, /36, /37, /38, /39, /40, /41, /42, /43, /48, /49, /65, /66, /67, /68, /69, /70, /71, /72, /73, /74, /75, /76, /77, /78, /82, /83, /84, /85, /86, /87, /91, /92, /95, /97, /98, (MS3155 CONTROLLED INTERFACE).
- INSTALLATION PROCEDURE MIP-103.
- PERFORMANCE SPECIFICATION MPS-103.
- FOR ADDITIONAL ORDERING INFORMATION SEE CH00-0250-019.

If this document is printed it becomes uncontrolled. Check for the latest revision

Raychem Adapters  
CUSTOMER DRAWING

2011 Tyco Electronics Corporation. All rights reserved.

UNLESS OTHERWISE SPECIFIED DIMENSIONS ARE IN INCHES AND TOLERANCES ARE: .XXX ± - .XX ± - ± -	DRAWN D JAIN	DATE 21NOV2011		TE Connectivity		
	CHECKED BERT W	DATE 21NOV2011				
	APPROVED	DATE				
MATERIAL SEE NOTES	THIRD ANGLE PROJECTION		TITLE SPIN-LOCK ADAPTER, HEAT SHRINKABLE MOLDED PART, SEALED, CODE 54			
FINISH -	CAD NAME SLM54_a.dwg	SIZE A	CAGE CODE: 06090	DWG. NO. SLM54	REV A	
	RPN: -	SCALE: NONE		SHEET 1 OF 3		

REVISIONS			
LTR	DESCRIPTION	DATE	APPROVED
A	RELEASED PER ECO-11-025206	12/16/11	B. WONG

e.g SLM 54AB - 1610A

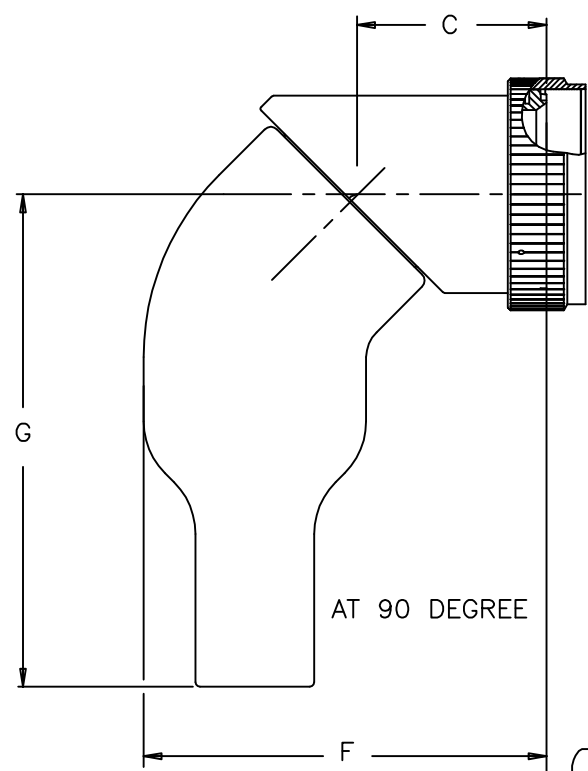
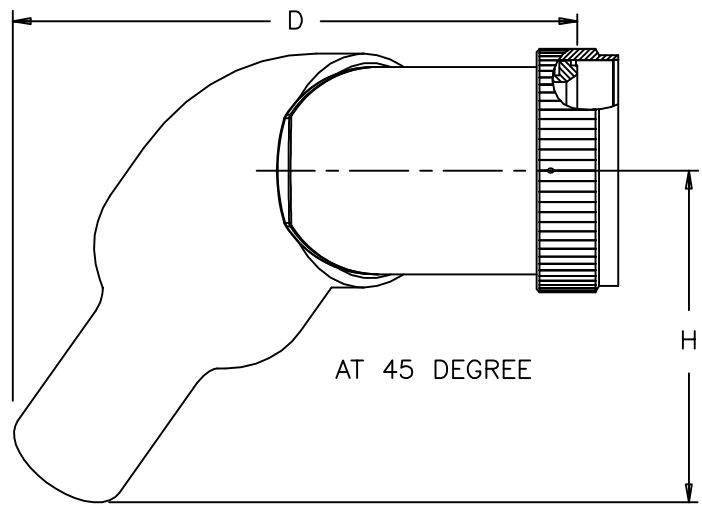
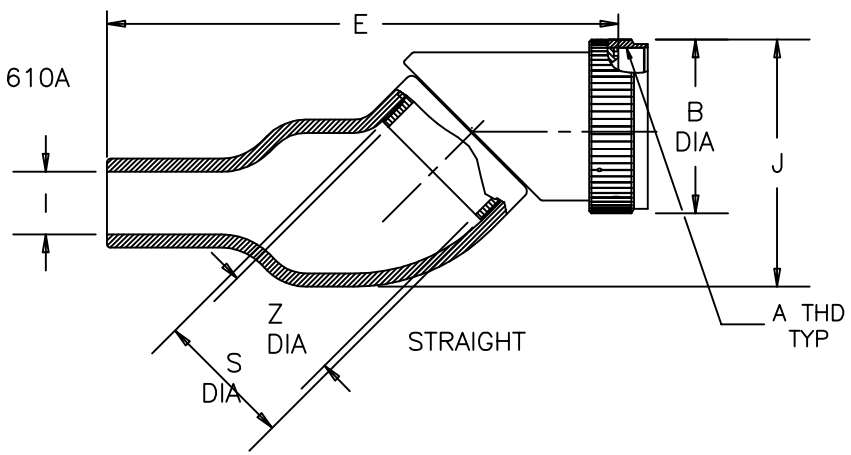

Raychem Adapters  
CUSTOMER DRAWING

If this document is printed it becomes uncontrolled. Check for the latest revision

SIZE A	CAGE CODE: 06090	DWG. NO. SLM54	REV A
SCALE: NONE		SHEET 2 OF 3	

REVISIONS			
LTR	DESCRIPTION	DATE	APPROVED
A	RELEASED PER ECO-11-025206	12/16/11	B. WONG

TABLE I

ORDER NO.	SHELL SIZE		AVAILABLE ENTRY SIZES		A METRIC THD CLASS	B DIA MAX	C MAX DIM
	4	5	SMALL	LARGE			
08		8 & 8S	04	-	.500"-20 UNF	.610 [15.49]	.58 [14.73]
10		10, 10S & 10SL	04	06	.625"-24 UNEF	.728 [18.50]	.55 [13.92]
12	7	12 & 12S	06	08	.750"-20 UNEF	.856 [21.75]	.69 [17.53]
14	12	14 & 14S	08	10	.875"-20 UNEF	.964 [24.50]	.89 [22.50]
16	19	16 & 16S	10	12	1.000"-20 UNEF	1.082 [27.49]	.94 [23.74]
18	27	18	10	14	1.062"-18 UNEF	1.161 [29.49]	.74 [18.80]
20	37	20	12	16	1.188"-18 UNEF	1.338 [33.98]	1.03 [26.17]
22		22	14	18	1.312"-18 UNEF	1.466 [37.23]	.97 [26.64]
24		24	16	20	1.438"-18 UNEF	1.592 [40.43]	1.37 [34.85]

TABLE II

ORDER NO.	D MAX DIM	E MAX DIM	F MAX DIM	G MAX DIM	H MAX DIM	I MAX DIM	J MAX DIM
08	1.9 [48.26]	2.42 [61.45]	1.42 [36.1]	1.84 [46.74]	1.05 [26.67]	1.05 [26.67]	1.15 [29.21]
10	2.13 [54.11]	2.86 [72.65]	1.51 [38.34]	2.32 [58.92]	1.38 [35.01]	1.10 [27.9]	1.34 [34.1]
12	2.26 [57.41]	2.98 [75.7]	1.64 [41.65]	2.33 [59.18]	1.38 [35.01]	1.20 [30.5]	1.41 [35.81]
14	2.68 [68.1]	3.45 [87.63]	2.0 [50.8]	2.55 [64.77]	1.53 [38.87]	1.15 [29.21]	1.59 [40.38]
16	2.69 [68.33]	3.49 [88.65]	2.05 [52.07]	2.55 [64.77]	1.53 [38.87]	1.20 [30.5]	1.65 [41.91]
18	2.71 [68.8]	3.61 [91.7]	1.96 [49.79]	2.89 [73.41]	1.78 [45.22]	1.15 [29.21]	1.85 [46.9]
20	3.01 [76.46]	3.92 [99.5]	2.27 [57.65]	2.89 [73.41]	1.81 [45.9]	1.20 [30.5]	1.92 [48.7]
22	3.18 [80.77]	4.33 [109.9]	2.42 [61.46]	3.36 [85.35]	2.21 [56.14]	1.20 [30.5]	2.19 [55.62]
24	3.67 [93.2]	4.65 [118.1]	2.76 [70.11]	3.36 [85.35]	2.16 [54.86]	1.20 [30.5]	2.25 [57.22]

TABLE III

ENTRY SIZE	MOLDED PART DESC	S DIA	Z +.010 - .020
04	245W032	.376 [9.55] .370 [9.40]	.250 [6.35]
06	245W042	.501 [12.73] .495 [12.57]	.375 [9.53]
08	245W042	.626 [15.90] .619 [15.72]	.500 [12.70]
10	245W053	.752 [19.10] .742 [18.85]	.625 [15.88]
12	245W053	.877 [22.28] .867 [22.02]	.750 [19.05]
14	245W063	1.002 [25.45] .991 [25.17]	.875 [22.23]
16	245W063	1.127 [28.63] 1.116 [28.35]	1.000 [25.40]
18	245W074	1.252 [31.80] 1.241 [31.52]	1.125 [28.58]
20	245W074	1.377 [34.98] 1.366 [34.70]	1.250 [31.75]

Raychem Adapters

CUSTOMER DRAWING

SIZE A	CAGE CODE: 06090	DWG. NO. SLM54	REV A
SCALE: NONE		SHEET 3 OF 3	