

**Product Features**

- High-Performance, Phase-Locked-Loop Clock Driver and zero-delay buffer
- Allows Clock Input to have Spread Spectrum modulation for EMI reduction
- Zero Input-to-Output delay
- Low jitter: Cycle-to-Cycle jitter  $\pm 75$ ps max.
- On-chip series damping resistor at clock output drivers for low noise and EMI reduction
- Operates at 3.3V V<sub>CC</sub>
- Wide range of Clock Frequencies 80 to 134 MHz
- Package: Plastic 8-pin 150-mil SOIC (W)  
Plastic 8-pin 150-mil SOIC (WE) Pb-free

**Product Description**

The PI6C2501A features a low-skew, low-jitter, phase-locked loop (PLL) clock driver. By connecting the CLK\_OUT output to the feedback FB\_IN input, the propagation delay from the CLK\_IN input to CLK\_OUT output will be nearly zero.

**Application**

If a system designer needs more than 16 outputs with the features just described, using two or more zero-delay buffers, such as the PI6C2509Q, or PI6C2510Q, is likely to be impractical. The device-to-device skew introduced can significantly reduce the performance. Pericom recommends using a zero-delay buffer and an eighteen output non-zero-delay buffer. As shown in Figure 1, this combination produces a zero-delay buffer with all the signal characteristics of the original zero-delay buffer, but with as many outputs as the non-zero-delay buffer part. For example, when combined with an eighteen output non-zero delay buffer, a system designer can create a seventeen-output zero-delay buffer.

**Logic Block Diagram**

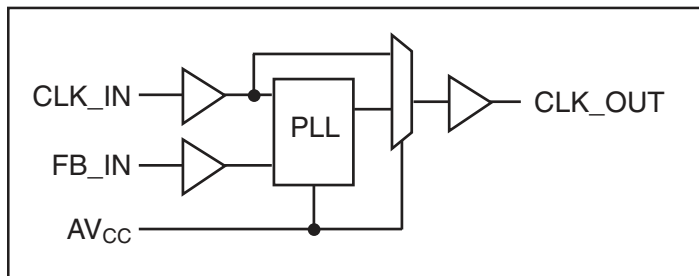

**Product Pin Configuration**

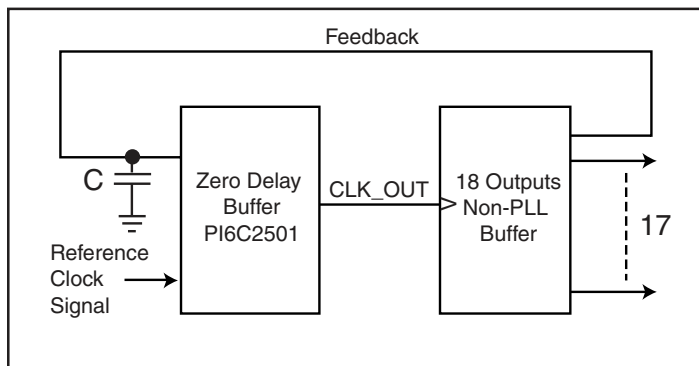
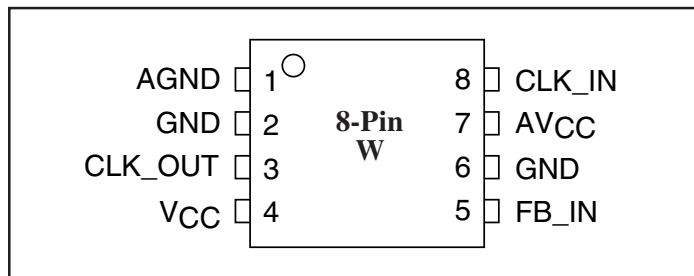

**Figure 1. This Combination Provides Zero-Delay Between the Reference Clock Signal and 17 Outputs**

### Pin Functions

Pin Name	Pin No.	Type	Description
CLK_IN	8	I	Reference Clock input. CLK_IN allows spread spectrum clock input.
FB_IN	5	I	Feedback input. FB_IN provides the feedback signal to the internal PLL.
CLK_OUT	3	O	Clock output. This output provides a low-skew copy of CLK_IN. The output has an embedded series-damping resistor.
AVCC	7	Power	Analog power supply. AVCC can be also used to bypass the PLL for test purpose. When AVCC is strapped to ground, PLL is bypassed and CLK_IN is buffered directly to the device outputs.
AGND	1	Ground	Analog ground. AGND provides the ground reference for the analog circuitry.
VCC	4	Power	Power supply.
GND	2, 6	Ground	Ground.

### DC Specifications<sup>(1)</sup> (Absolute maximum ratings over operating free-air temperature range)

Symbol	Parameter	Min.	Max.	Units
V <sub>I</sub>	Input voltage range	-0.5	V <sub>CC</sub> + 0.5	V
V <sub>O</sub>	Output voltage range			
V <sub>I,DC</sub>	DC input voltage		3.8	
I <sub>O,DC</sub>	DC output current		100	mA
Power	Maximum power dissipation at T <sub>A</sub> = 55°C in still air		1.0	W
T <sub>STG</sub>	Storage temperature	-65	150	°C

**Note:**

1. Stress beyond those listed under “absolute maximum ratings” may cause permanent damage to the device.

Parameter	Test Conditions	V <sub>CC</sub>	Min.	Typ.	Max.	Units
I <sub>CC</sub>	V <sub>I</sub> = V <sub>CC</sub> or GND; I <sub>O</sub> = 0 <sup>(2)</sup> Standby Current	3.6V			10	μA
C <sub>I</sub>	V <sub>I</sub> = V <sub>CC</sub> or GND	3.3V		4		pF
C <sub>O</sub>	V <sub>O</sub> = V <sub>CC</sub> or GND			6		

**Note:**

2. Continuous Output Current

### Recommended Operating Conditions

Symbol	Parameter	Min.	Max.	Units
V <sub>CC</sub>	Supply voltage	3.0	3.6	V
V <sub>IH</sub>	High level input voltage	2.0		
V <sub>IL</sub>	Low level input voltage		0.8	
V <sub>I</sub>	Input voltage	0	V <sub>CC</sub>	
T <sub>A</sub>	Operating free-air temperature	0	70	°C

**Electrical Characteristics** (Over Recommended Operating Free-Air Temperature Range

Pull Up/Down Currents of PI6C2501A,  $V_{CC} = 3.0V$ )

Symbol	Parameter	Condition	Min.	Max.	Units
I <sub>OH</sub>	Pull-up current	V <sub>out</sub> = 2.4V		-13.6	mA
	Pull-up current	V <sub>out</sub> = 2.0V		-22	
I <sub>OL</sub>	Pull-down current	V <sub>out</sub> = 0.8V	19		
	Pull-down current	V <sub>out</sub> = 0.55V	13		

**AC Specifications**

(Timing requirements over recommended ranges of supply voltage and operating free-air temperature)

Symbol	Parameter	Min.	Max.	Units
F <sub>CLK</sub>	Clock frequency	80	134	MHz
D <sub>CYI</sub>	Input clock duty cycle	40	60	%
	Stabilization Time after power up		1	ms

**Switching Characteristics<sup>(3)</sup>**

(Over recommended ranges of supply voltage and operating free-air temperature, C<sub>L</sub> = 30pF)

Parameter	From (Input)	To (Output)	V <sub>CC</sub> = 3.3V ±0.3V, 0-70°C			Units
			Min.	Typ.	Max.	
t <sub>phase error without jitter</sub>	CLK_IN↑ at 100 & 66 MHz	FB_IN↑	-150		+150	ps
Jitter, cycle-to-cycle	At 100 & 66 MHz	CLK_OUT	-75		+75	
Duty cycle			45		55	%
t <sub>r</sub> , rise-time, 0.4V to 2.0V					1.0	ns
t <sub>f</sub> , fall-time, 2.0V to 0.4V					1.1	

**Note:**

3. These switching parameters are guaranteed by design.

**Package Mechanical Information:** Plastic 8-pin SOIC Package.

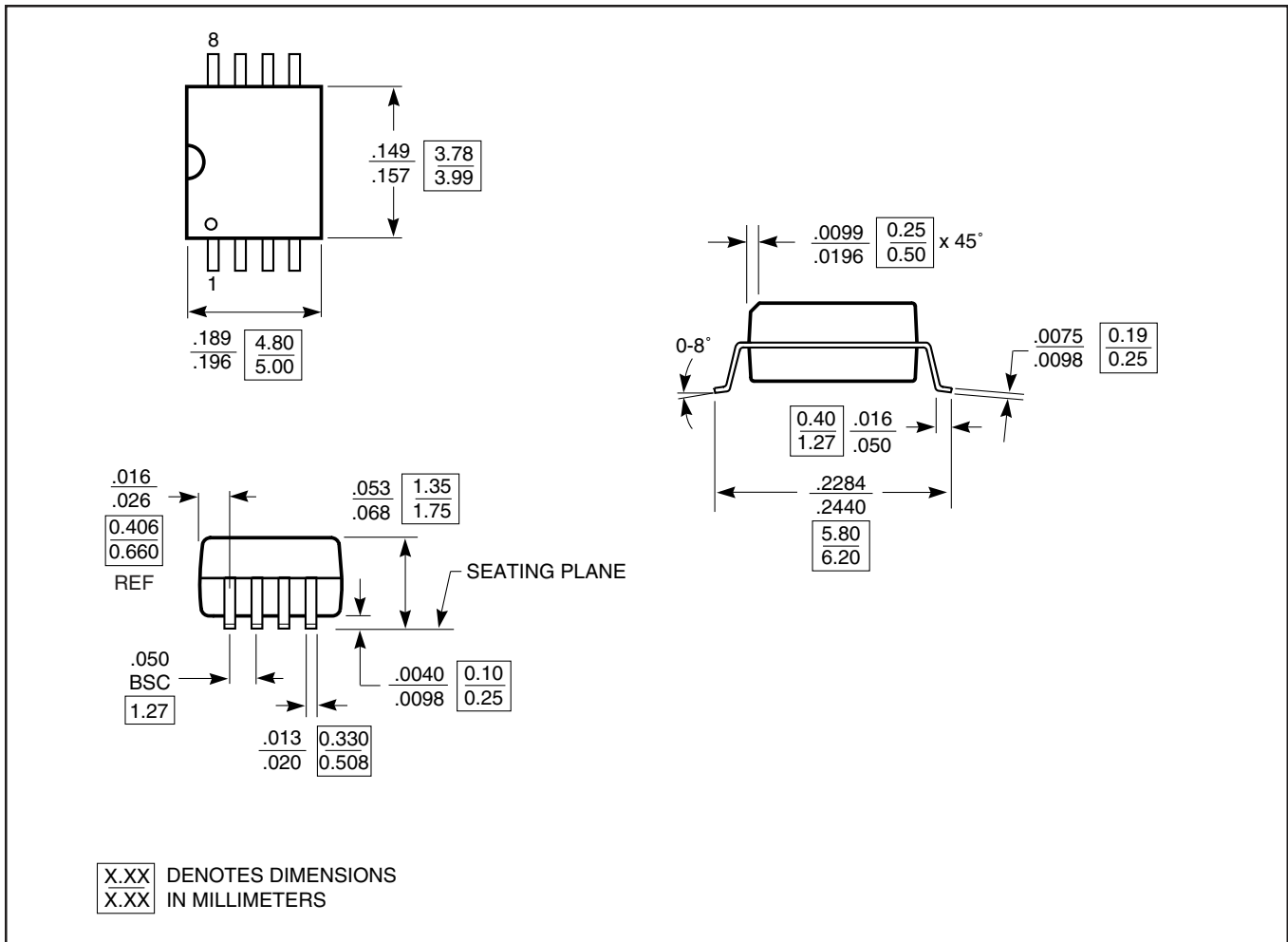

**Ordering Information**

Ordering Code	Package Name	Package Type	Operating Range
PI6C2501AW	W	8-pin 150-mil SOIC	Commercial
PI6C2501AWE	W	8-pin 150-mil SOIC	Commercial