

PART NAME NEMA 4X ENCLOSURE

PART No. PNR-2600, PNR-2600-C AND PNR-2600-DG
PNR-2601, PNR-2601-C AND PNR-2601-DG

REV. DATE 11-17-08

INDUSTRY STANDARDS:
 POLYCARBONATE (LIGHT GRAY AND CLEAR)
 UL94-HB FLAMMABILITY RATING (UL FILE #E41613)
 UV STABILIZED
 SERVICE TEMPERATURE RANGE: -40°C TO +120°C
 ABS (DARK GRAY)
 UL94-HB FLAMMABILITY RATING (UL FILE #E56070)
 SERVICE TEMPERATURE RANGE: -40°C TO +80°C

PART NUMBER	DIMENSION			
	A	B	C	D
PNR-2600, PNR-2600-C AND PNR-2600-DG	1.645	1.586	2.186	1.734
PNR-2601, PNR-2601-C AND PNR-2601-DG	3.016	2.955	3.555	3.103

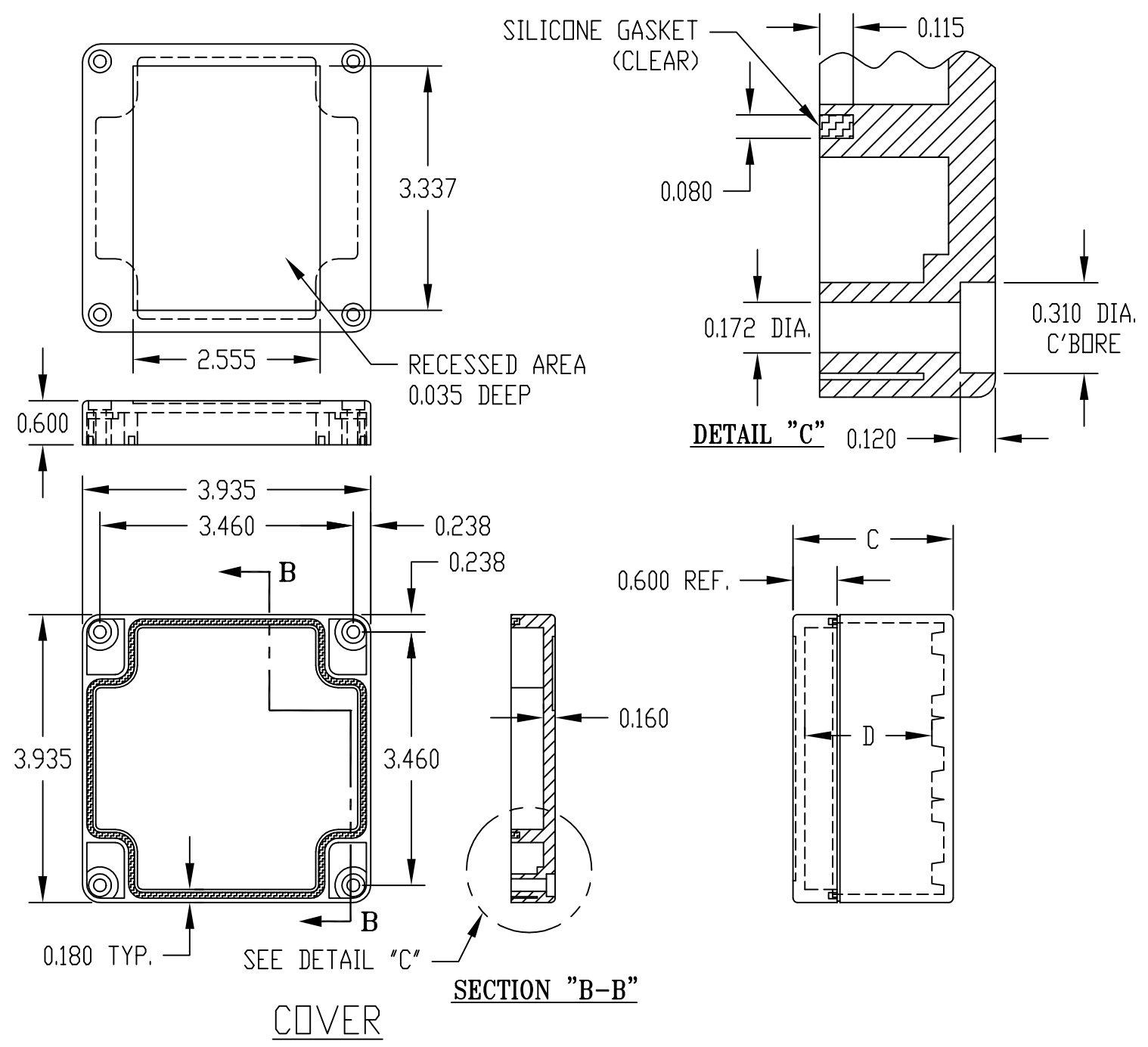
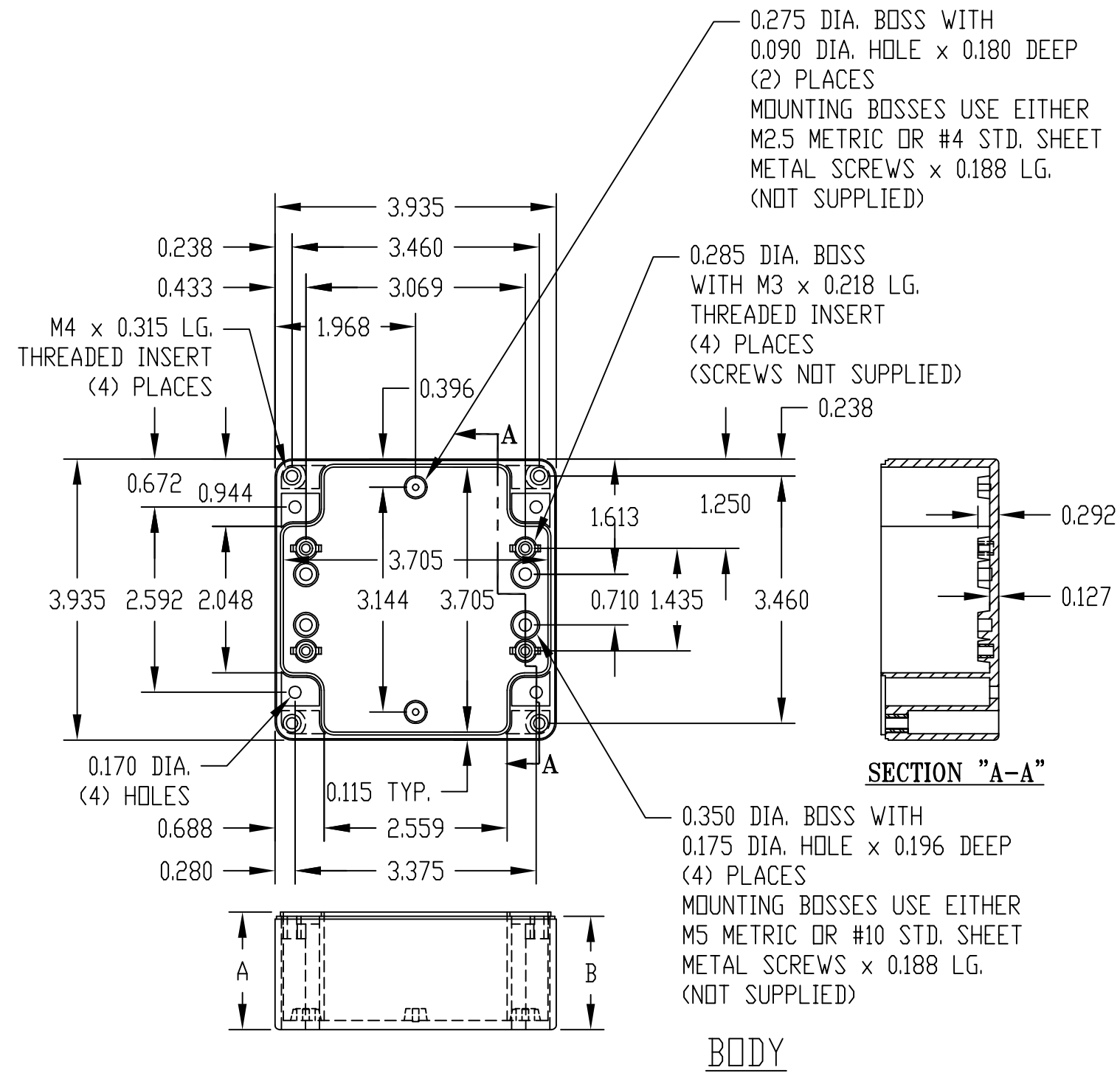

NOTE: ALL DIMENSIONS HAVE ±0.015 TOLERANCE UNLESS OTHERWISE SPECIFIED.

PART NUMBER	MATERIAL		FINISH		HARDWARE KIT
	BODY	COVER	BODY	COVER	
PNR-2600 & PNR-2601	POLYCARBONATE		LIGHT GRAY		KIT CONTAINS (4) M4 x 17mm (0.668") LG. SCREWS FOR ASSEMBLY
PNR-2600-C & PNR-2601-C	POLYCARBONATE		LIGHT GRAY	CLEAR	
PNR-2600-DG & PNR-2601-DG	HIGH-IMPACT ABS		DARK GRAY		