

SPECIFICATIONS

(RoHS Compliant)



Model Number: TNE3A
Part Number: 19020172A

Version: 01
Jan 09, 2018

Mechanical Drawing:

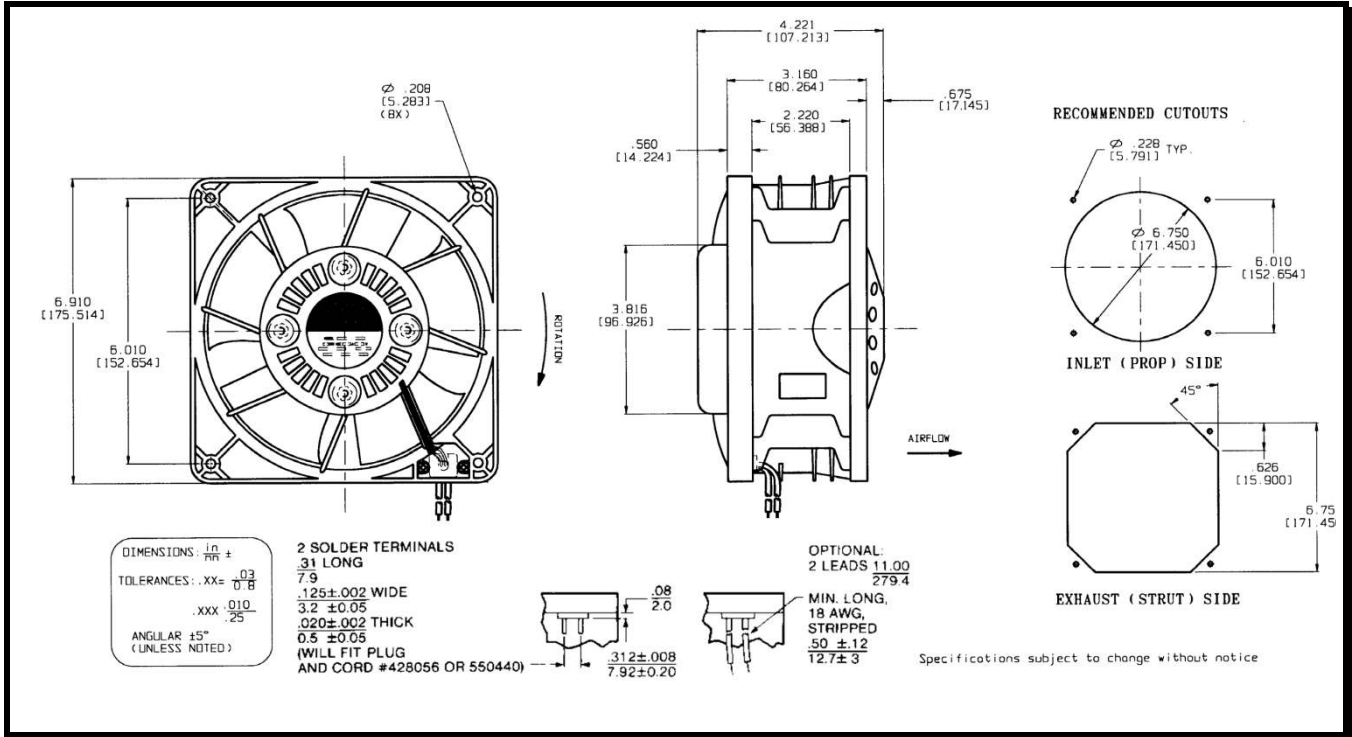

Motor:

Nominal Voltage = 220/230 VAC
Frequency = 50 / 60 Hz
Nominal Running Current = 0.22 / 0.25 Amps
Max. Locked Rotor Current = 0.60 / 0.65 Amps
Running Power = 52 / 59 Watts
Average Speed = 2820 / 3350 RPM
Bearings = Ball
Air Flow = 280 / 340 CFM
Acoustic = 61.6 / 65.4 dBA

Construction:

Venturi: Plastic, Black, UL 94V-0
Propeller & Cover: Plastic, Black, UL 94V-0

Life Expectancy:

This fan is designed for continuous duty life of 45,000 hours at 60°C.

Additional Features:

Permanent Split Capacitor
Automatic Reset Thermal Protector
Thermal Shutdown Protection
Class B Insulation
Operating Temperature: -10°C to 70°C
Storage Temperature: -40°C to 85°C

Termination:

2x0.12" Terminals

Agency Approvals:

UL, CUL, CE

PQ Curve:

