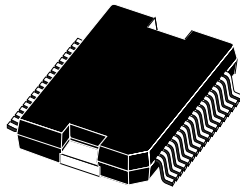
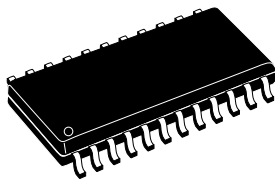

DMOS driver for 3-phase brushless DC motor

Datasheet - production data

**PowerSO36****SO24
(20 + 2 + 2)****Ordering numbers:****L6235PD (PowerSO36)
L6235D (SO24)**

- 60° and 120° hall effect decoding logic
- Brake function
- Tachometer output for speed loop
- Cross conduction protection
- Thermal shutdown
- Undervoltage lockout
- Integrated fast freewheeling diodes

Description

The L6235 device is a DMOS fully integrated 3-phase motor driver with overcurrent protection.

Realized in BCD technology, the device combines isolated DMOS power transistors with CMOS and bipolar circuits on the same chip.

The device includes all the circuitry needed to drive a 3-phase BLDC motor including: a 3-phase DMOS bridge, a constant off time PWM current controller and the decoding logic for single ended hall sensors that generates the required sequence for the power stage.

Available in PowerSO36 and SO24 (20 + 2 + 2) packages, the L6235 device features a non-dissipative overcurrent protection on the high-side power MOSFETs and thermal shutdown.

Features

- Operating supply voltage from 8 to 52 V
- 5.6 A output peak current (2.8 A DC)
- $R_{DS(ON)}$ 0.3 Ω typ. value at $T_j = 25^\circ\text{C}$
- Operating frequency up to 100 KHz
- Non-dissipative overcurrent detection and protection
- Diagnostic output
- Constant t_{OFF} PWM current controller
- Slow decay synchr. rectification

Contents

| | | |
|-----------|---|-----------|
| 1 | Block diagram | 3 |
| 2 | Maximum ratings | 4 |
| 3 | Pin connections | 6 |
| 4 | Electrical characteristics | 8 |
| 5 | Circuit description | 11 |
| | 5.1 Power stages and charge pump | 11 |
| | 5.2 Logic inputs | 12 |
| 6 | PWM current control | 13 |
| 7 | Slow decay mode | 17 |
| 8 | Decoding logic | 18 |
| 9 | Tachometer | 20 |
| 10 | Non-dissipative overcurrent detection and protection | 22 |
| 11 | Application information | 25 |
| | 11.1 Output current capability and IC power dissipation | 26 |
| | 11.2 Thermal management | 27 |
| 12 | Package information | 30 |
| | 12.1 PowerSO36 package information | 30 |
| | 12.2 SO24 package information | 32 |
| 13 | Revision history | 33 |

1 Block diagram

Figure 1. Block diagram

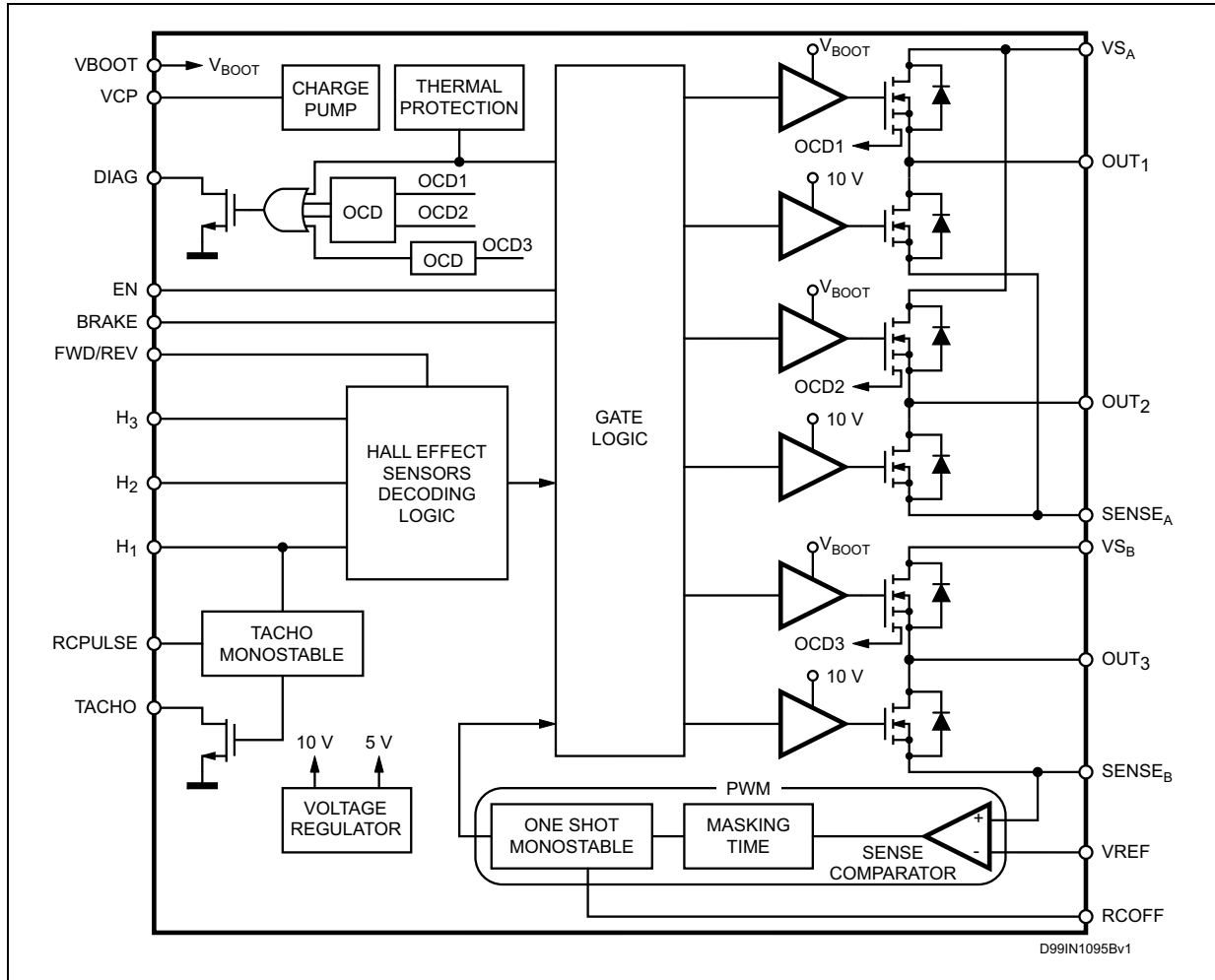

2 Maximum ratings

Table 1. Absolute maximum ratings

| Symbol | Parameter | Test conditions | Value | Unit |
|----------------------|---|--|------------|------|
| V_S | Supply voltage | $V_{SA} = V_{SB} = V_S$ | 60 | V |
| V_{OD} | Differential voltage between: V_{SA} , OUT_1 , OUT_2 , $SENSE_A$ and V_{SB} , OUT_3 , $SENSE_B$ | $V_{SA} = V_{SB} = V_S = 60\text{ V};$ $V_{SENSE_A} = V_{SENSE_B} = \text{GND}$ | 60 | V |
| V_{BOOT} | Bootstrap peak voltage | $V_{SA} = V_{SB} = V_S$ | $V_S + 10$ | V |
| V_{IN} , V_{EN} | Logic inputs voltage range | - | -0.3 to 7 | V |
| V_{REF} | Voltage range at pin VREF | - | -0.3 to 7 | V |
| V_{RCOFF} | Voltage range at pin RCOFF | - | -0.3 to 7 | V |
| $V_{RCPULSE}$ | Voltage range at pin RCPULSE | - | -0.3 to 7 | V |
| V_{SENSE} | Voltage range at pins $SENSE_A$ and $SENSE_B$ | - | -1 to 4 | V |
| $I_{S(\text{peak})}$ | Pulsed supply current (for each V_{SA} and V_{SB} pin) | $V_{SA} = V_{SB} = V_S; T_{PULSE} < 1\text{ ms}$ | 7.1 | A |
| I_S | DC supply current (for each V_{SA} and V_{SB} pin) | $V_{SA} = V_{SB} = V_S$ | 2.8 | A |
| T_{stg} , T_{OP} | Storage and operating temperature range | - | -40 to 150 | °C |

Table 2. Recommended operating condition

| Symbol | Parameter | Test conditions | Min. | Max. | Unit |
|-------------|---|---|----------|--------|--------|
| V_S | Supply voltage | $V_{SA} = V_{SB} = V_S$ | 12 | 52 | V |
| V_{OD} | Differential voltage between: V_{SA} , OUT_1 , OUT_2 , $SENSE_A$ and V_{SB} , OUT_3 , $SENSE_B$ | $V_{SA} = V_{SB} = V_S;$ $V_{SENSE_A} = V_{SENSE_B}$ | - | 52 | V |
| V_{REF} | Voltage range at pin VREF | - | -0.1 | 5 | V |
| V_{SENSE} | Voltage range at pins $SENSE_A$ and $SENSE_B$ | (pulsed $t_W < t_{rr}$) (DC) | -6 -1 | 6 1 | V V |
| I_{OUT} | DC output current | $V_{SA} = V_{SB} = V_S$ | - | 2.8 | A |
| f_{SW} | Switching frequency | - | - | 100 | KHz |

Table 3. Thermal data

| Symbol | Description | SO24 | PowerSO36 | Unit |
|------------------|--|------|-----------|------|
| $R_{th(j-pins)}$ | Maximum thermal resistance junction pins | 14 | - | °C/W |
| $R_{th(j-case)}$ | Maximum thermal resistance junction case | - | 1 | °C/W |
| $R_{th(j-amb)1}$ | Maximum thermal resistance junction ambient ⁽¹⁾ | 51 | - | °C/W |
| $R_{th(j-amb)1}$ | Maximum thermal resistance junction ambient ⁽²⁾ | - | 35 | °C/W |
| $R_{th(j-amb)1}$ | Maximum thermal resistance junction ambient ⁽³⁾ | - | 15 | °C/W |
| $R_{th(j-amb)2}$ | Maximum thermal resistance junction ambient ⁽⁴⁾ | 77 | 62 | °C/W |

1. Mounted on a multilayer FR4 PCB with a dissipating copper surface on the bottom side of 6 cm² (with a thickness of 35 μm).
2. Mounted on a multilayer FR4 PCB with a dissipating copper surface on the top side of 6 cm² (with a thickness of 35 μm).
3. Mounted on a multilayer FR4 PCB with a dissipating copper surface on the top side of 6 cm² (with a thickness of 35 μm), 16 via holes and a ground layer.
4. Mounted on a multilayer FR4 PCB without any heatsinking surface on the board.

3 Pin connections

Figure 2. Pin connections (top view)

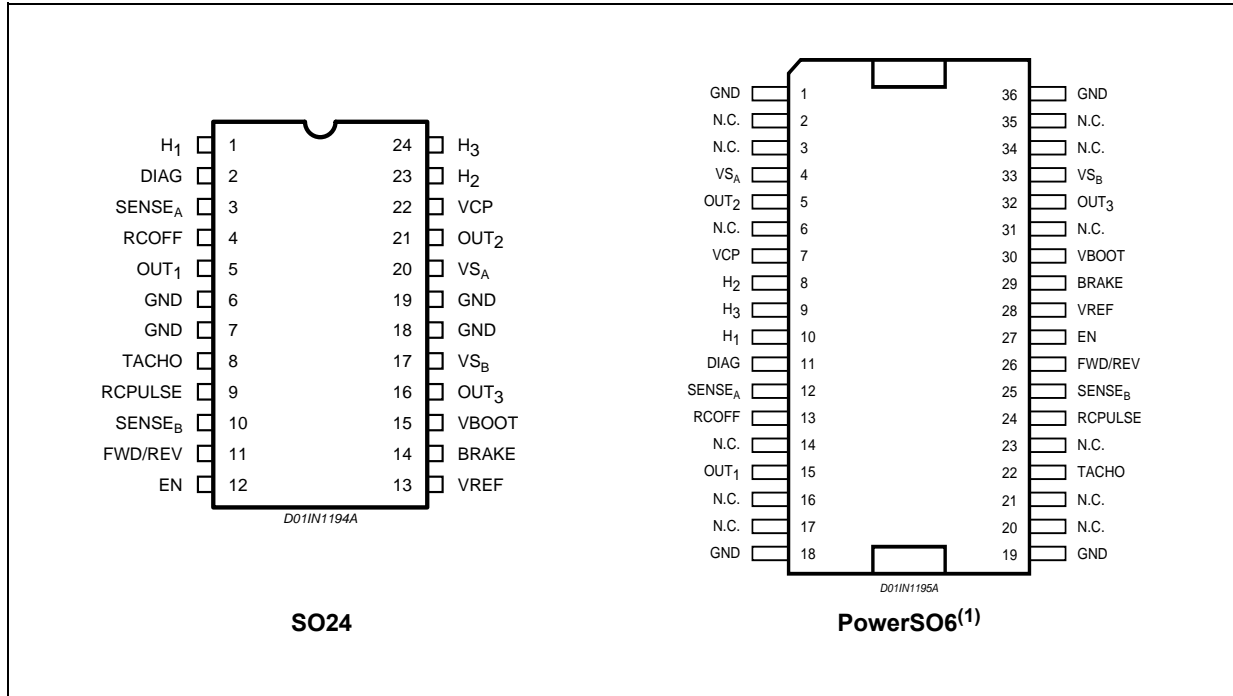

1. The slug is internally connected to pins 1, 18, 19 and 36 (GND pins).

Table 4. Pin description

| Package | | Name | Type | Function |
|---------|-----------|--------------------|-------------------|--|
| SO24 | PowerSO36 | | | |
| Pin no. | Pin no. | | | |
| 1 | 10 | H ₁ | Sensor input | Single ended hall effect sensor input 1. |
| 2 | 11 | DIAG | Open drain output | Overcurrent detection and thermal protection pin. An internal open drain transistor pulls to GND when an overcurrent on one of the high-side MOSFETs is detected or during thermal protection. |
| 3 | 12 | SENSE _A | Power supply | Half-bridge 1 and half-bridge 2 source pin. This pin must be connected together with pin SENSE _B to power ground through a sensing power resistor. |
| 4 | 13 | RCOFF | RC pin | RC network pin. A parallel RC network connected between this pin and ground sets the current controller OFF-time. |
| 5 | 15 | OUT ₁ | Power output | Output 1 |

Table 4. Pin description (continued)

| Package | | Name | Type | Function |
|--------------|---------------|--------------------|-------------------|--|
| SO24 | PowerSO36 | | | |
| Pin no. | Pin no. | | | |
| 6, 7, 18, 19 | 1, 18, 19, 36 | GND | GND | Ground terminals. On SO24 package, these pins are also used for heat dissipation toward the PCB. On PowerSO36 package the slug is connected on these pins. |
| 8 | 22 | TACHO | Open drain output | Frequency-to-voltage open drain output. Every pulse from pin H ₁ is shaped as a fixed and adjustable length pulse. |
| 9 | 24 | RCPULSE | RC pin | RC network pin. A parallel RC network connected between this pin and ground sets the duration of the monostable pulse used for the frequency-to-voltage converter. |
| 10 | 25 | SENSE _B | Power supply | Half-bridge 3 source pin. This pin must be connected together with pin SENSE _A to power ground through a sensing power resistor. At this pin also the inverting input of the sense comparator is connected. |
| 11 | 26 | FWD/REV | Logic input | Selects the direction of the rotation. HIGH logic level sets forward operation, whereas LOW logic level sets reverse operation. If not used, it has to be connected to GND or +5 V. |
| 12 | 27 | EN | Logic input | Chip enable. LOW logic level switches OFF all power MOSFETs. If not used, it has to be connected to +5 V. |
| 13 | 28 | VREF | Logic input | Current controller reference voltage. Do not leave this pin open or connect to GND. |
| 14 | 29 | BRAKE | Logic input | Brake input pin. LOW logic level switches ON all high-side power MOSFETs, implementing the brake function. If not used, it has to be connected to +5 V. |
| 15 | 30 | VBOOT | Supply voltage | Bootstrap voltage needed for driving the upper power MOSFETs. |
| 16 | 32 | OUT ₃ | Power output | Output 3. |
| 17 | 33 | VS _B | Power supply | Half-bridge 3 power supply voltage. It must be connected to the supply voltage together with pin VS _A . |
| 20 | 4 | VS _A | Power supply | Half-bridge 1 and half-bridge 2 power supply voltage. It must be connected to the supply voltage together with pin VS _B . |
| 21 | 5 | OUT ₂ | Power output | Output 2. |
| 22 | 7 | VCP | Output | Charge pump oscillator output. |
| 23 | 8 | H ₂ | Sensor input | Single ended hall effect sensor input 2. |
| 24 | 9 | H ₃ | Sensor input | Single ended hall effect sensor input 3. |

4 Electrical characteristics

Table 5. Electrical characteristics
($V_S = 48\text{ V}$, $T_{\text{amb}} = 25\text{ °C}$, unless otherwise specified)

| Symbol | Parameter | Test conditions | Min. | Typ. | Max. | Unit |
|---|--|---|-------|------|------|---------------|
| $V_{\text{Sth(ON)}}$ | Turn ON threshold | - | 6.6 | 7.4 | - | V |
| $V_{\text{Sth(OFF)}}$ | Turn OFF threshold | - | 5.6 | 6 | 6.4 | V |
| I_S | Quiescent supply current | All bridges OFF; $T_j = -25\text{ to }125\text{ °C}^{(1)}$ | - | 5 | 10 | mA |
| $T_{\text{J(OFF)}}$ | Thermal shutdown temperature | - | - | 165 | - | °C |
| Output DMOS transistors | | | | | | |
| $R_{\text{DS(ON)}}$ | High-side switch ON resistance | $T_j = 25\text{ °C}$ | - | 0.34 | 0.4 | Ω |
| | | $T_j = 125\text{ °C}^{(1)}$ | - | 0.53 | 0.59 | Ω |
| | Low-side switch ON resistance | $T_j = 25\text{ °C}$ | - | 0.28 | 0.34 | Ω |
| | | $T_j = 125\text{ °C}^{(1)}$ | - | 0.47 | 0.53 | Ω |
| I_{DSS} | Leakage current | EN = low; OUT = V_{CC} | - | - | 2 | mA |
| | | EN = low; OUT = GND | -0.15 | - | - | mA |
| Source drain diodes | | | | | | |
| V_{SD} | Forward ON voltage | $I_{\text{SD}} = 2.8\text{ A}$, EN = LOW | - | 1.15 | 1.3 | V |
| t_{rr} | Reverse recovery time | $I_f = 2.8\text{ A}$ | - | 300 | - | ns |
| t_{fr} | Forward recovery time | - | - | 200 | - | ns |
| Logic input (H1, H2, H3, EN, FWD/REV, BRAKE) | | | | | | |
| V_{IL} | Low level logic input voltage | - | -0.3 | - | 0.8 | V |
| V_{IH} | High level logic input voltage | - | 2 | - | 7 | V |
| I_{IL} | Low level logic input current | GND logic input voltage | -10 | - | - | μA |
| I_{IH} | High level logic input current | 7 V logic input voltage | - | - | 10 | μA |
| $V_{\text{th(ON)}}$ | Turn-ON input threshold | - | - | 1.8 | 2.0 | V |
| $V_{\text{th(OFF)}}$ | Turn-OFF input threshold | - | 0.8 | 1.3 | - | V |
| V_{thHYS} | Input thresholds hysteresis | - | 0.25 | 0.5 | - | V |
| Switching characteristics | | | | | | |
| $t_{\text{D(on)EN}}$ | Enable to out turn-ON delay time ⁽²⁾ | $I_{\text{LOAD}} = 2.8\text{ A}$, resistive load | 110 | 250 | 400 | ns |
| $t_{\text{D(off)EN}}$ | Enable to out turn-OFF delay time ⁽²⁾ | $I_{\text{LOAD}} = 2.8\text{ A}$, resistive load | 300 | 550 | 800 | ns |
| $t_{\text{D(on)IN}}$ | Other logic inputs to output turn-ON delay time | $I_{\text{LOAD}} = 2.8\text{ A}$, resistive load | - | - | 2 | μs |
| $t_{\text{D(off)IN}}$ | Other logic inputs to out turn-OFF delay time | $I_{\text{LOAD}} = 2.8\text{ A}$, resistive load | - | - | 2 | μs |
| t_{RISE} | Output rise time ⁽²⁾ | $I_{\text{LOAD}} = 2.8\text{ A}$, resistive load | 40 | - | 250 | ns |
| t_{FALL} | Output fall time ⁽²⁾ | $I_{\text{LOAD}} = 2.8\text{ A}$, resistive load | 40 | - | 250 | ns |
| t_{DT} | Deadtime | | 0.5 | 1 | - | μs |
| f_{CP} | Charge pump frequency | $T_j = -25\text{ to }125\text{ °C}^{(1)}$ | - | 0.6 | 1 | MHz |

Table 5. Electrical characteristics (continued)
 ($V_S = 48\text{ V}$, $T_{\text{amb}} = 25\text{ °C}$, unless otherwise specified)

| Symbol | Parameter | Test conditions | Min. | Typ. | Max. | Unit |
|---|--|--|------|---------|------|---------------|
| PWM comparator and monostable | | | | | | |
| I_{RCOFF} | Source current at pin RC_{OFF} | $V_{\text{RCOFF}} = 2.5\text{ V}$ | 3.5 | 5.5 | - | mA |
| V_{OFFSET} | Offset voltage on sense comparator | $V_{\text{ref}} = 0.5\text{ V}$ | - | ± 5 | - | mV |
| t_{prop} | Turn OFF propagation delay ⁽³⁾ | $V_{\text{ref}} = 0.5\text{ V}$ | - | 500 | - | ns |
| t_{blank} | Internal blanking time on sense comparator | - | - | 1 | - | μs |
| $t_{\text{ON(min)}}$ | Minimum on time | - | - | 1.5 | 2 | μs |
| t_{OFF} | PWM recirculation time | $R_{\text{OFF}} = 20\text{ k}\Omega$; $C_{\text{OFF}} = 1\text{ nF}$ | - | 13 | - | μs |
| | | $R_{\text{OFF}} = 100\text{ k}\Omega$; $C_{\text{OFF}} = 1\text{ nF}$ | - | 61 | - | μs |
| I_{BIAS} | Input bias current at pin VREF | - | - | - | 10 | μA |
| TACHO monostable | | | | | | |
| I_{RCPULSE} | Source current at pin RCPULSE | $V_{\text{RCPULSE}} = 2.5\text{ V}$ | 3.5 | 5.5 | - | mA |
| t_{PULSE} | Monostable of time | $R_{\text{PUL}} = 20\text{ k}\Omega$; $C_{\text{PUL}} = 1\text{ nF}$ | - | 12 | - | μs |
| | | $R_{\text{PUL}} = 100\text{ k}\Omega$; $C_{\text{PUL}} = 1\text{ nF}$ | - | 60 | - | μs |
| R_{TACHO} | Open drain ON resistance | - | - | 40 | 60 | Ω |
| Overcurrent detection and protection | | | | | | |
| I_{SOVER} | Supply overcurrent protection threshold | $T_J = -25\text{ to }125\text{ °C}^{(1)}$ | 4.0 | 5.6 | 7.1 | A |
| R_{OPDR} | Open drain ON resistance | $I_{\text{DIAG}} = 4\text{ mA}$ | - | 40 | 60 | Ω |
| I_{OH} | OCD high level leakage current | $V_{\text{DIAG}} = 5\text{ V}$ | - | 1 | - | μA |
| $t_{\text{OCD(ON)}}$ | OCD turn-ON delay time ⁽⁴⁾ | $I_{\text{DIAG}} = 4\text{ mA}$; $C_{\text{DIAG}} < 100\text{ pF}$ | - | 200 | - | ns |
| $t_{\text{OCD(OFF)}}$ | OCD turn-OFF delay time ⁽⁴⁾ | $I_{\text{DIAG}} = 4\text{ mA}$; $C_{\text{DIAG}} < 100\text{ pF}$ | - | 100 | - | ns |

1. Tested at 25 °C in a restricted range and guaranteed by characterization.

2. See [Figure 3: Switching characteristic definition](#).

3. Measured applying a voltage of 1 V to pin SENSE and a voltage drop from 2 V to 0 V to pin VREF.

4. See [Figure 4: Overcurrent detection timing definition](#).

Figure 3. Switching characteristic definition

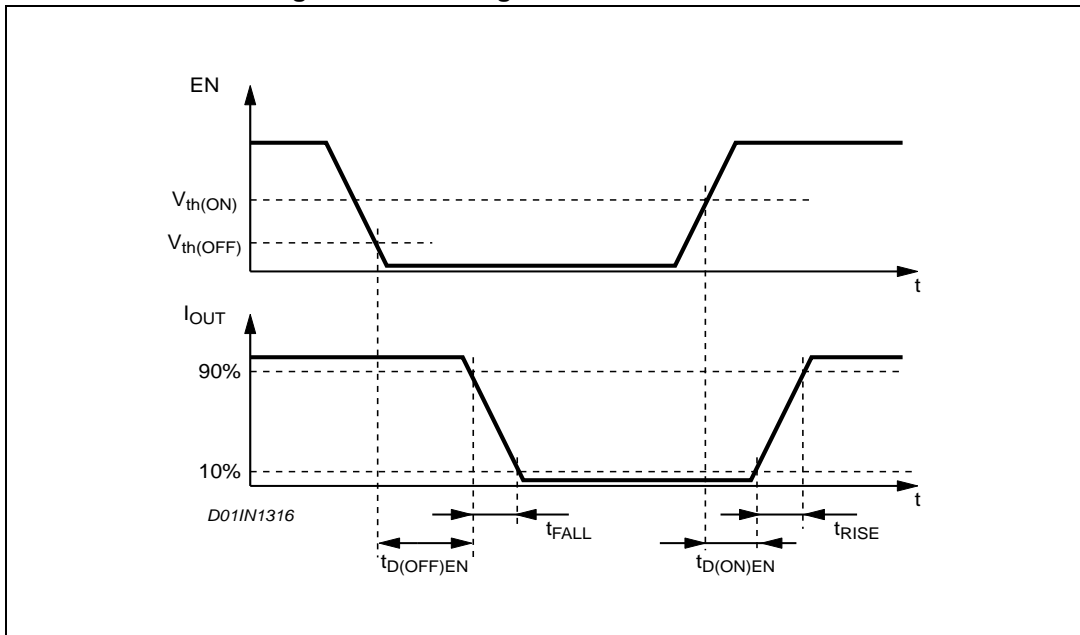
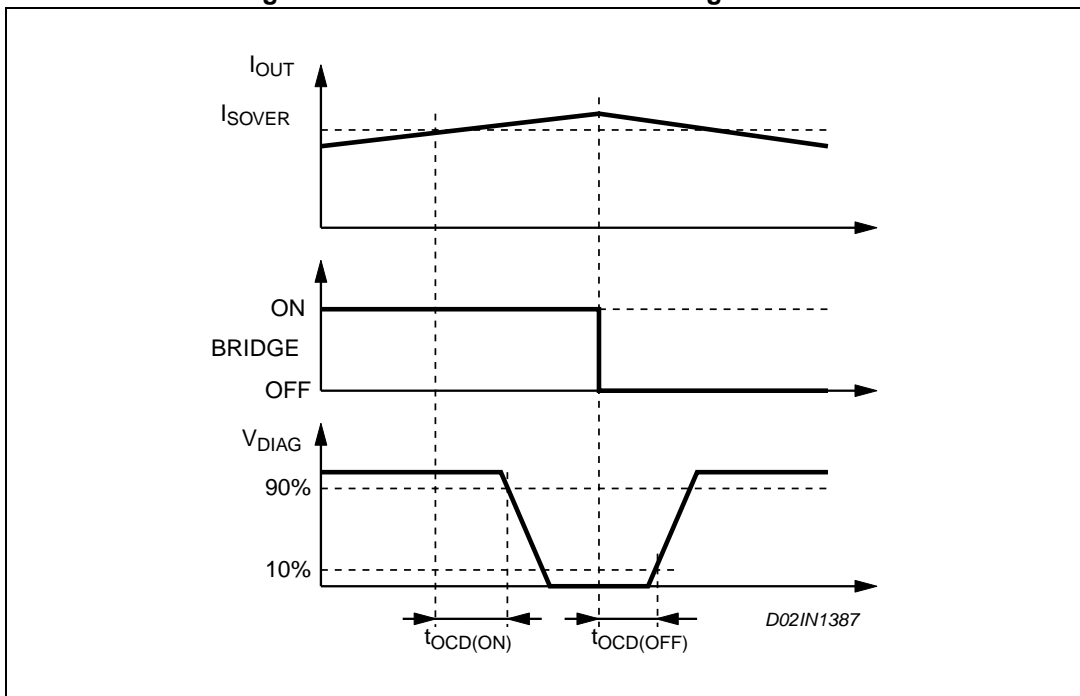

Figure 4. Overcurrent detection timing definition



5 Circuit description

5.1 Power stages and charge pump

The L6235 device integrates a 3-phase bridge, which consists of 6 power MOSFETs connected as shown in [Figure 1: Block diagram on page 3](#). Each power MOS has an $R_{DS(ON)} = 0.3$ (typical value at 25 °C) with intrinsic fast freewheeling diode. Switching patterns are generated by the PWM current controller and the hall effect sensor decoding logic (see [Section 6: PWM current control on page 13](#) and [Section 8: Decoding logic on page 18](#)). Cross conduction protection is implemented by using a deadtime ($t_{DT} = 1 \mu s$ typical value) set by internal timing circuit between the turn off and turn on of two power MOSFETs in one leg of a bridge.

Pins VS_A and VS_B MUST be connected together to the supply voltage (V_S).

Using N-channel power MOS for the upper transistors in the bridge requires a gate drive voltage above the power supply voltage. The bootstrapped supply (V_{BOOT}) is obtained through an internal oscillator and few external components to realize a charge pump circuit as shown in [Figure 5](#). The oscillator output (pin VCP) is a square wave at 600 KHz (typically) with 10 V amplitude. Recommended values/part numbers for the charge pump circuit are shown in [Table 6](#).

Table 6. Charge pump external component values

| Component | Value |
|------------|--------------|
| C_{BOOT} | 22 0nF |
| C_P | 10 nF |
| R_P | 100 Ω |
| D_1 | 1N4148 |
| D_2 | 1N4148 |

Figure 5. Charge pump circuit

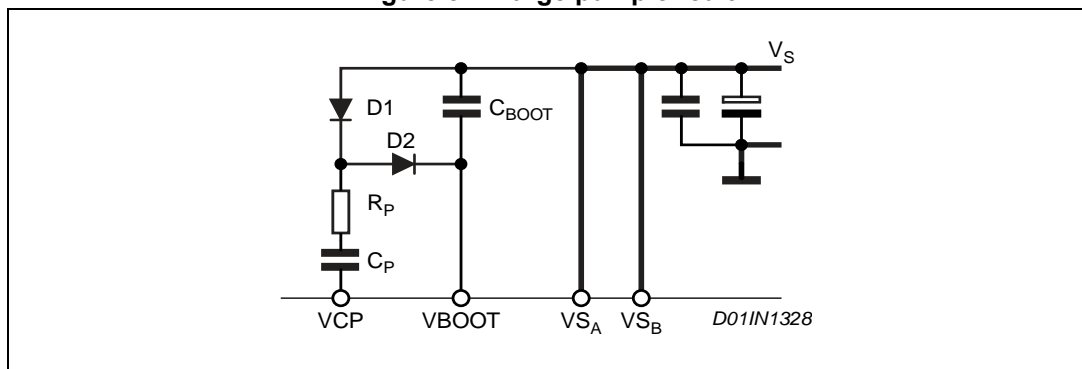

5.2 Logic inputs

Pins FWD/REV, BRAKE, EN, H₁, H₂ and H₃ are TTL/CMOS compatible logic inputs. The internal structure is shown in [Figure 6](#). Typical value for turn-ON and turn-OFF thresholds are respectively $V_{th(ON)} = 1.8\text{ V}$ and $V_{th(OFF)} = 1.3\text{ V}$.

Pin EN (enable) may be used to implement overcurrent and thermal protection by connecting it to the open collector DIAG output. If the protection and an external disable function are both desired, the appropriate connection must be implemented. When the external signal is from an open collector output, the circuit in [Figure 7](#) can be used. For external circuits that are push-pull outputs the circuit in [Figure 8](#) could be used. The resistor R_{EN} should be chosen in the range from 2.2 K Ω to 180 K Ω . Recommended values for R_{EN} and C_{EN} are respectively 100 K Ω and 5.6 nF. More information for selecting the values can be found in [Section 10: Non-dissipative overcurrent detection and protection on page 22](#).

Figure 6. Logic input internal structure

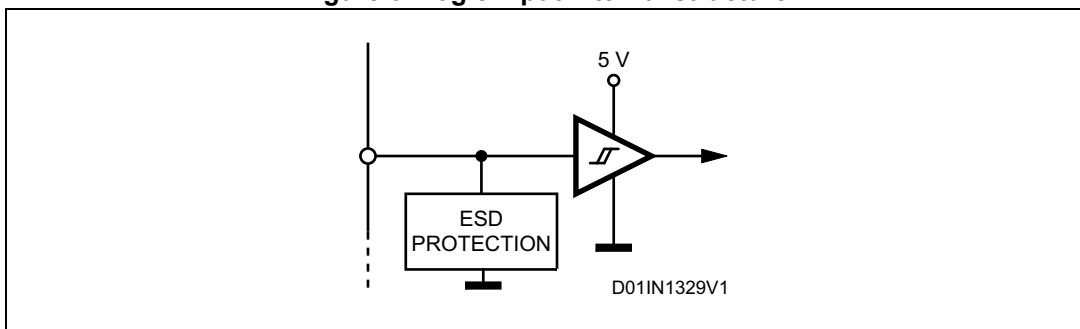

Figure 7. Pin EN open collector driving

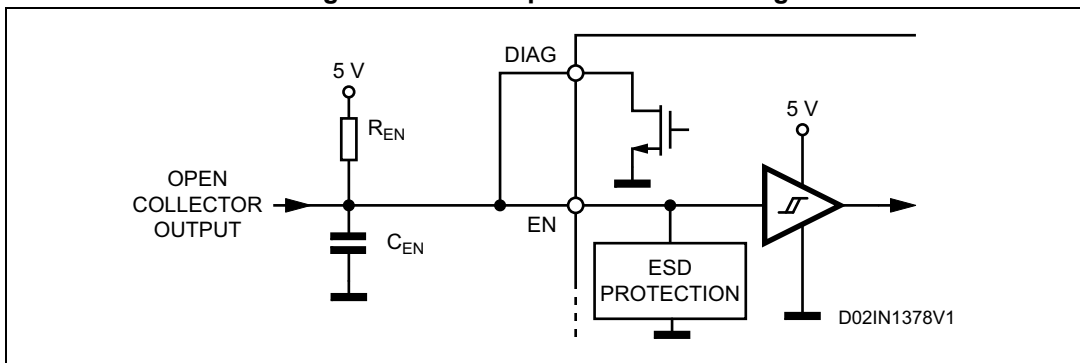

Figure 8. Pin EN push-pull driving

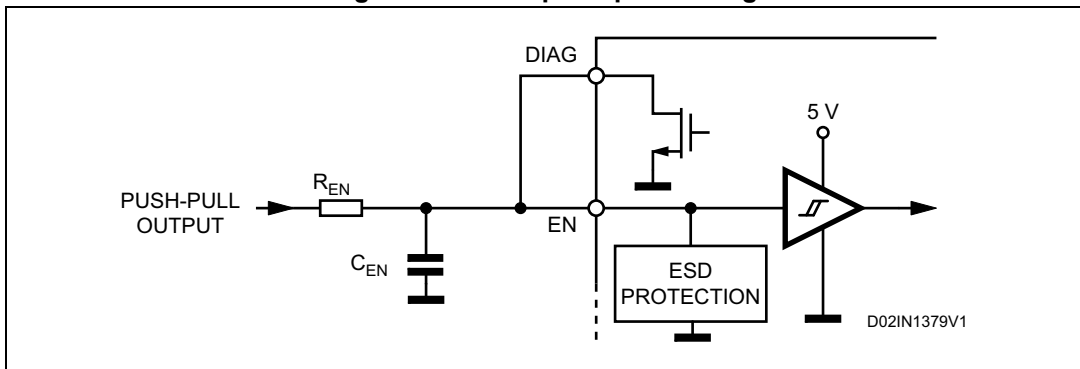

Figure 10. Output current regulation waveforms

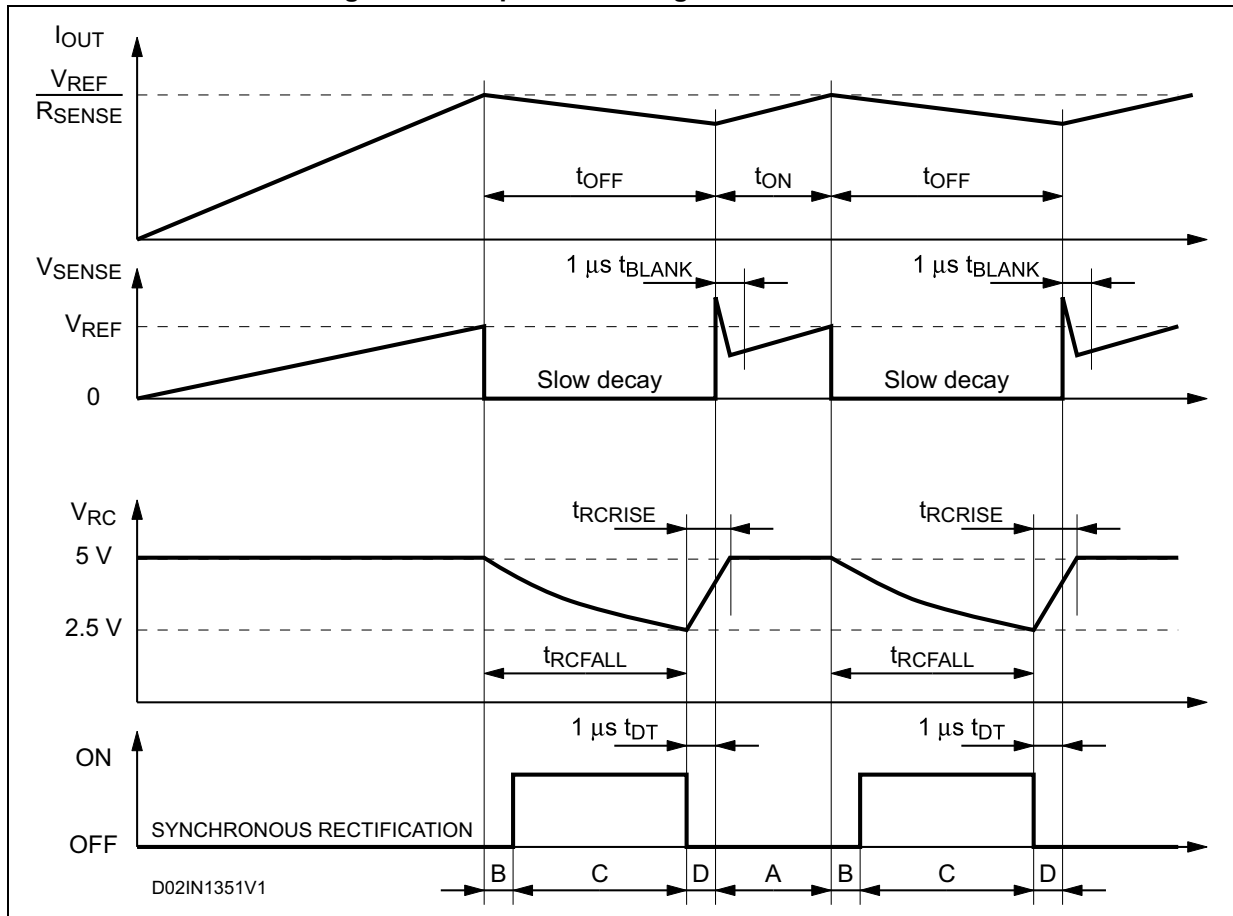

Figure 11 shows the magnitude of the off time t_{OFF} versus C_{OFF} and R_{OFF} values. It can be approximately calculated from the equations:

Equation 1

$$t_{RCFALL} = 0.6 \cdot R_{OFF} \cdot C_{OFF}$$

$$t_{OFF} = t_{RCFALL} + t_{DT} = 0.6 \cdot R_{OFF} \cdot C_{OFF} + t_{DT}$$

where R_{OFF} and C_{OFF} are the external component values and t_{DT} is the internally generated deadtime with:

Equation 2

$$20 \text{ K}\Omega \leq R_{OFF} \leq 100 \text{ K}\Omega$$

$$0.47 \text{ nF} \leq C_{OFF} \leq 100 \text{ nF}$$

$$t_{DT} = 1 \mu\text{s (typical value)}$$

Therefore:

Equation 3

$$t_{OFF(MIN)} = 6.6 \mu\text{s}$$

$$t_{OFF(MAX)} = 6 \text{ ms}$$

These values allow a sufficient range of t_{OFF} to implement the drive circuit for most motors.

The capacitor value chosen for C_{OFF} also affects the rise time t_{RCRISE} of the voltage at the pin RCOFF. The rise time t_{RCRISE} will only be an issue if the capacitor is not completely charged before the next time the monostable is triggered. Therefore, the on time t_{ON} , which depends by motors and supply parameters, has to be bigger than t_{RCRISE} for allowing a good current regulation by the PWM stage. Furthermore, the on time t_{ON} cannot be smaller than the minimum on time $t_{ON(MIN)}$.

Equation 4

$$\begin{cases} t_{ON} > t_{ON(MIN)} = 1.5\mu\text{s (typ. value)} \\ t_{ON} > t_{RCRISE} - t_{DT} \\ t_{RCRISE} = 600 \cdot C_{OFF} \end{cases}$$

Figure 12 shows the lower limit for the on time t_{ON} for having a good PWM current regulation capacity. It has to be said that t_{ON} is always bigger than $t_{ON(MIN)}$ because the device imposes this condition, but it can be smaller than $t_{RCRISE} - t_{DT}$. In this last case the device continues to work but the off time t_{OFF} is not more constant.

So, small C_{OFF} value gives more flexibility for the applications (allows smaller on time and, therefore, higher switching frequency), but, the smaller is the value for C_{OFF} , the more influential will be the noises on the circuit performance.

Figure 11. t_{OFF} versus C_{OFF} and R_{OFF}

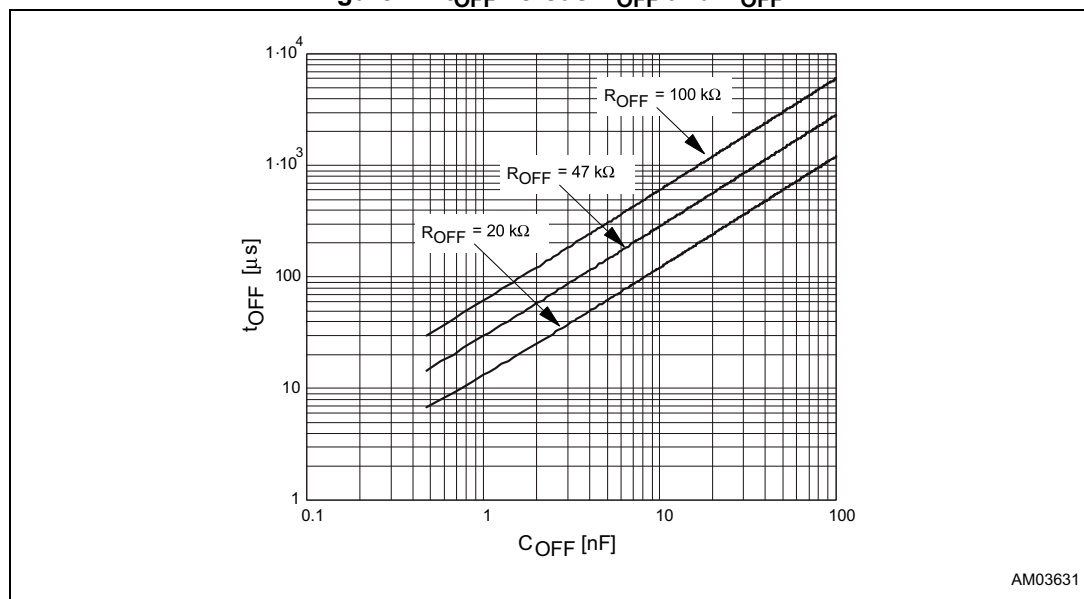
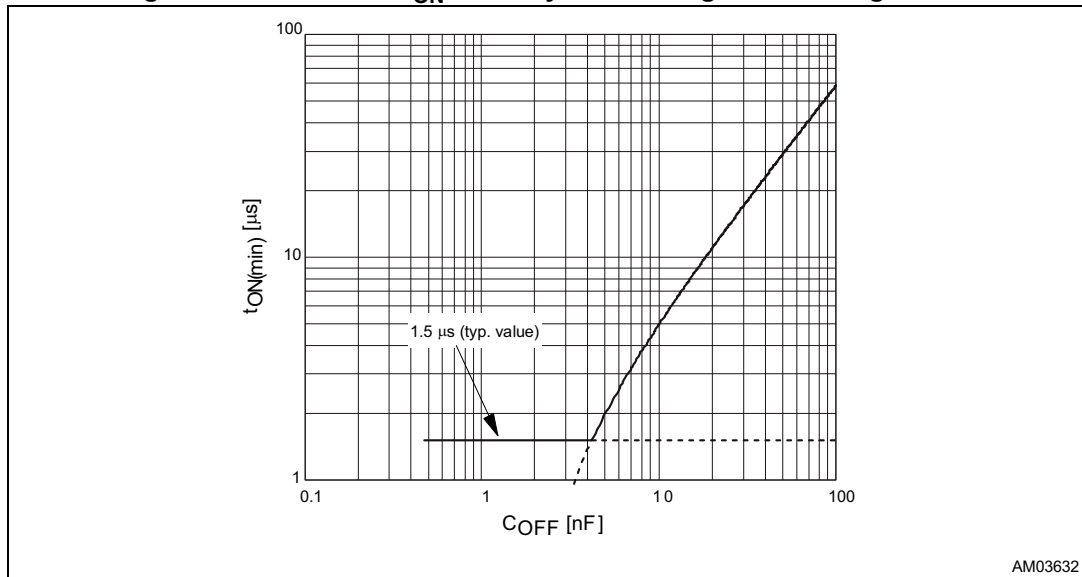

Figure 12. Area where t_{ON} can vary maintaining the PWM regulation



7 Slow decay mode

Figure 13 shows the operation of the bridge in the slow decay mode during the off time. At any time only two legs of the 3-phase bridge are active, therefore only the two active legs of the bridge are shown in *Figure 13* and the third leg will be off. At the start of the off time, the lower power MOS is switched off and the current recirculates around the upper half of the bridge. Since the voltage across the coil is low, the current decays slowly. After the deadtime the upper power MOS is operated in the synchronous rectification mode reducing the impedance of the freewheeling diode and the related conducting losses. When the monostable times out, upper MOS that was operating the synchronous mode turns off and the lower power MOS is turned on again after some delay set by the deadtime to prevent cross conduction.

Figure 13. Slow decay mode output stage configurations

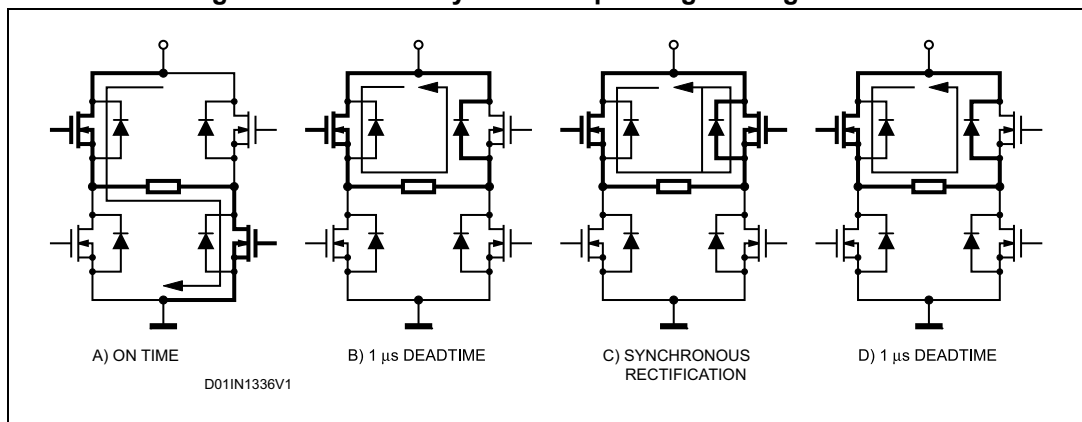

8 Decoding logic

The decoding logic section is a combinatory logic that provides the appropriate driving of the 3-phase bridge outputs according to the signals coming from the three hall sensors that detect rotor position in a 3-phase BLDC motor. This novel combinatory logic discriminates between the actual sensor positions for sensors spaced at 60, 120, 240 and 300 electrical degrees. This decoding method allows the implementation of a universal IC without dedicating pins to select the sensor configuration.

There are eight possible input combinations for three sensor inputs. Six combinations are valid for rotor positions with 120 electrical degrees sensor phasing (see [Figure 14](#), positions 1, 2, 3a, 4, 5 and 6a) and six combinations are valid for rotor positions with 60 electrical degrees phasing (see [Figure 15](#), positions 1, 2, 3b, 4, 5 and 6b). Four of them are in common (1, 2, 4 and 5) whereas there are two combinations used only in 120 electrical degrees sensor phasing (3a and 6a) and two combinations used only in 60 electrical degrees sensor phasing (3b and 6b).

The decoder can drive motors with different sensor configuration simply by following [Table 7](#). For any input configuration (H_1 , H_2 and H_3) there is one output configuration (OUT_1 , OUT_2 and OUT_3). The output configuration 3a is the same as 3b and analogously output configuration 6a is the same as 6b.

The sequence of the hall codes for 300 electrical degrees phasing is the reverse of 60 and the sequence of the hall codes for 240 phasing is the reverse of 120. So, by decoding the 60 and the 120 codes it is possible to drive the motor with all the four conventions by changing the direction set.

Table 7. 60 and 120 electrical degree decoding logic in forward direction

| Hall 120° | 1 | 2 | 3a | - | 4 | 5 | 6a | - |
|-----------|--------|--------|--------|--------|--------|--------|--------|--------|
| Hall 60° | 1 | 2 | - | 3b | 4 | 5 | - | 6b |
| H_1 | H | H | L | H | L | L | H | L |
| H_2 | L | H | H | H | H | L | L | L |
| H_3 | L | L | L | H | H | H | H | L |
| OUT_1 | Vs | High Z | GND | GND | GND | High Z | Vs | Vs |
| OUT_2 | High Z | Vs | Vs | Vs | High Z | GND | GND | GND |
| OUT_3 | GND | GND | High Z | High Z | Vs | Vs | High Z | High Z |
| Phasing | 1 -> 3 | 2 -> 3 | 2 -> 1 | 2 -> 1 | 3 -> 1 | 3 -> 2 | 1 -> 2 | 1 -> 2 |

Figure 14. 120° hall sensor sequence

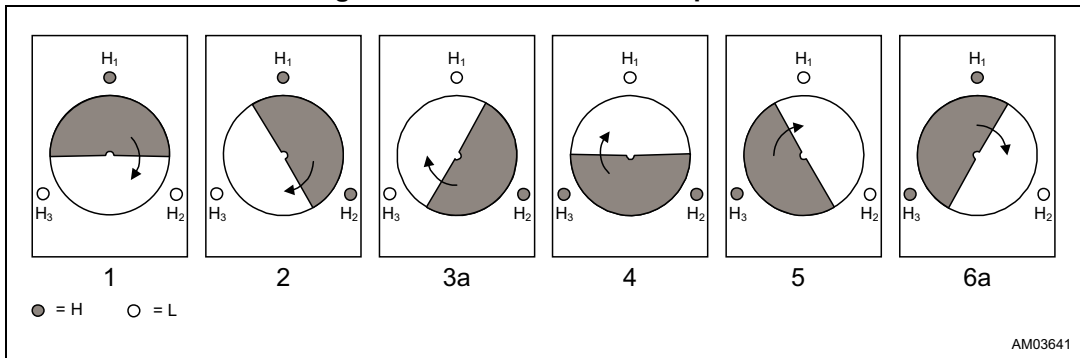
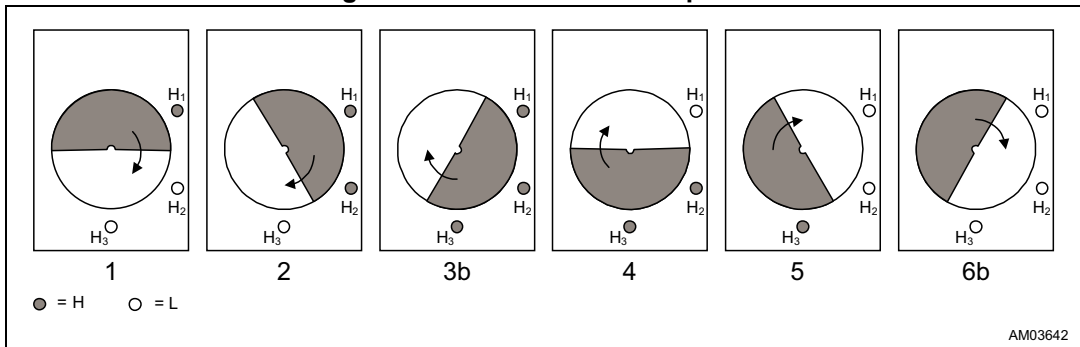

Figure 15. 60° hall sensor sequence



9 Tachometer

A tachometer function consists of a monostable, with constant off time (t_{PULSE}), whose input is one hall effect signal (H_1). It allows developing an easy speed control loop by using an external op amp, as shown in [Figure 16](#). For component values refer to [Section 11: Application information on page 25](#).

The monostable output drives an open drain output pin (TACHO). At each rising edge of the hall effect sensors H_1 , the monostable is triggered and the MOSFET connected to the pin TACHO is turned off for a constant time t_{PULSE} (see [Figure 17](#)). The off time t_{PULSE} can be set using the external RC network (R_{PUL} , C_{PUL}) connected to the pin RCPULSE. [Figure 18](#) gives the relation between t_{PULSE} and C_{PUL} , R_{PUL} . We have approximately:

Equation 5

$$t_{PULSE} = 0.6 \cdot R_{PUL} \cdot C_{PUL}$$

where C_{PUL} should be chosen in the range 1nF to 100 nF and R_{PUL} in the range 20 K Ω to 100 K Ω .

By connecting the tachometer pin to an external pull-up resistor, the output signal average value V_M is proportional to the frequency of the hall effect signal and, therefore, to the motor speed. This realizes a simple frequency-to-voltage converter. An op amp, configured as an integrator, filters the signal and compares it with a reference voltage V_{REF} , which sets the speed of the motor.

Equation 6

$$V_M = \frac{t_{PULSE}}{T} \cdot V_{DD}$$

Figure 16. TACHO operation waveforms

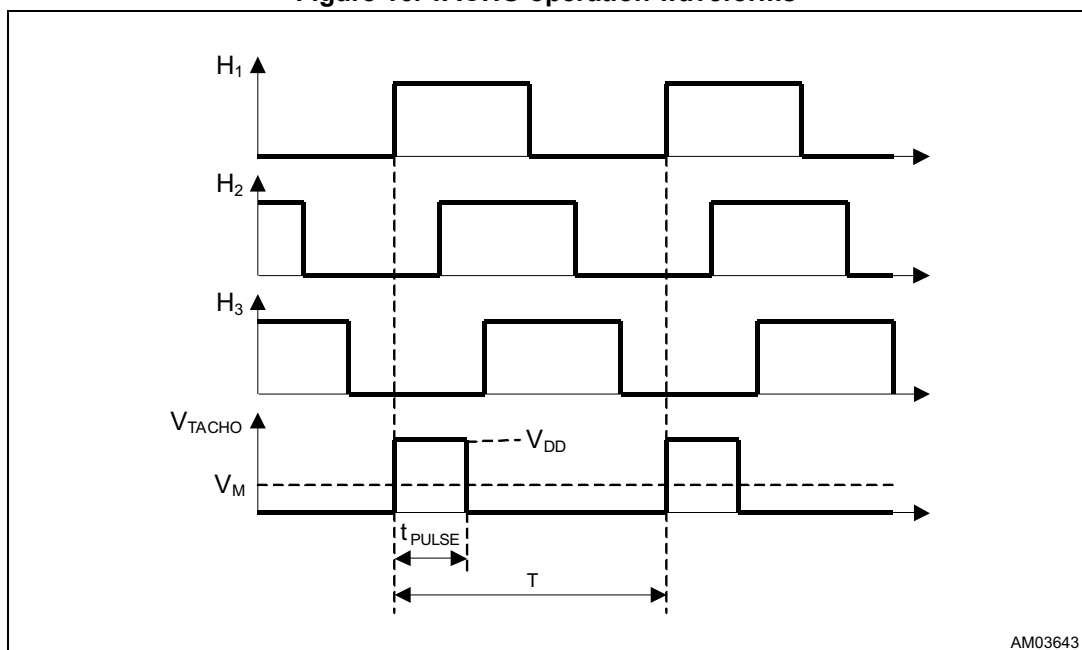
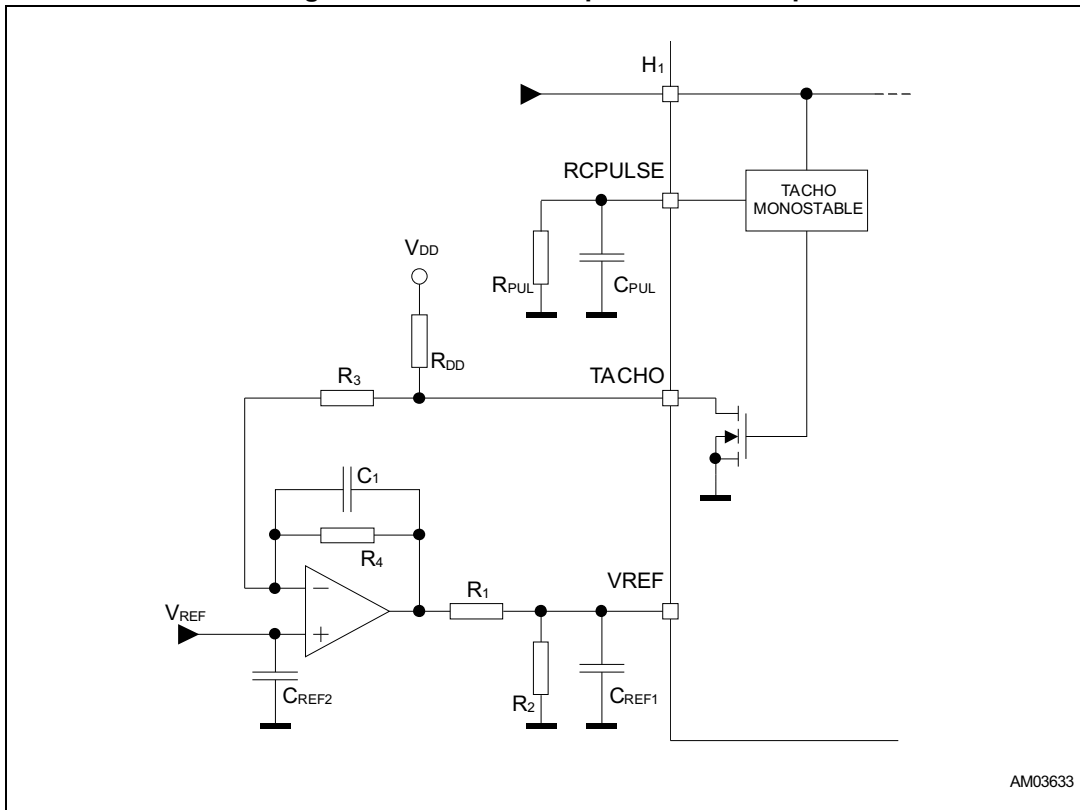
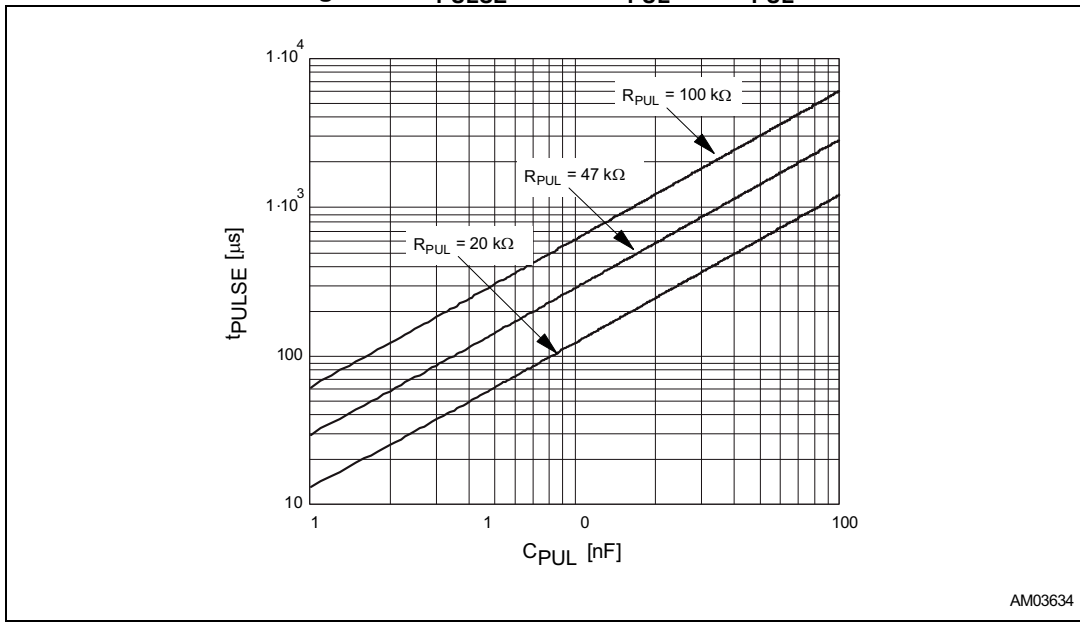

Figure 17. Tachometer speed control loop



AM03633

Figure 18. t_{PULSE} versus C_{PUL} and R_{PUL}



AM03634

10 Non-dissipative overcurrent detection and protection

The L6235 device integrates an “Overcurrent Detection” circuit (OCD) for full protection. This circuit provides output to output and output to ground short-circuit protection as well. With this internal overcurrent detection, the external current sense resistor normally used and its associated power dissipation are eliminated. *Figure 19* shows a simplified schematic for the overcurrent detection circuit.

To implement the overcurrent detection, a sensing element that delivers a small but precise fraction of the output current is implemented with each high-side power MOS. Since this current is a small fraction of the output current there is very little additional power dissipation. This current is compared with an internal reference current I_{REF} . When the output current reaches the detection threshold (typically $I_{SOVER} = 5.6\text{ A}$) the OCD comparator signals a fault condition. When a fault condition is detected, an internal open drain MOS with a pull down capability of 4 mA connected to pin DIAG is turned on.

The pin DIAG can be used to signal the fault condition to a μC or to shut down the 3-phase bridge simply by connecting it to pin EN and adding an external R-C (see R_{EN} , C_{EN}).

Figure 19. Overcurrent protection simplified schematic

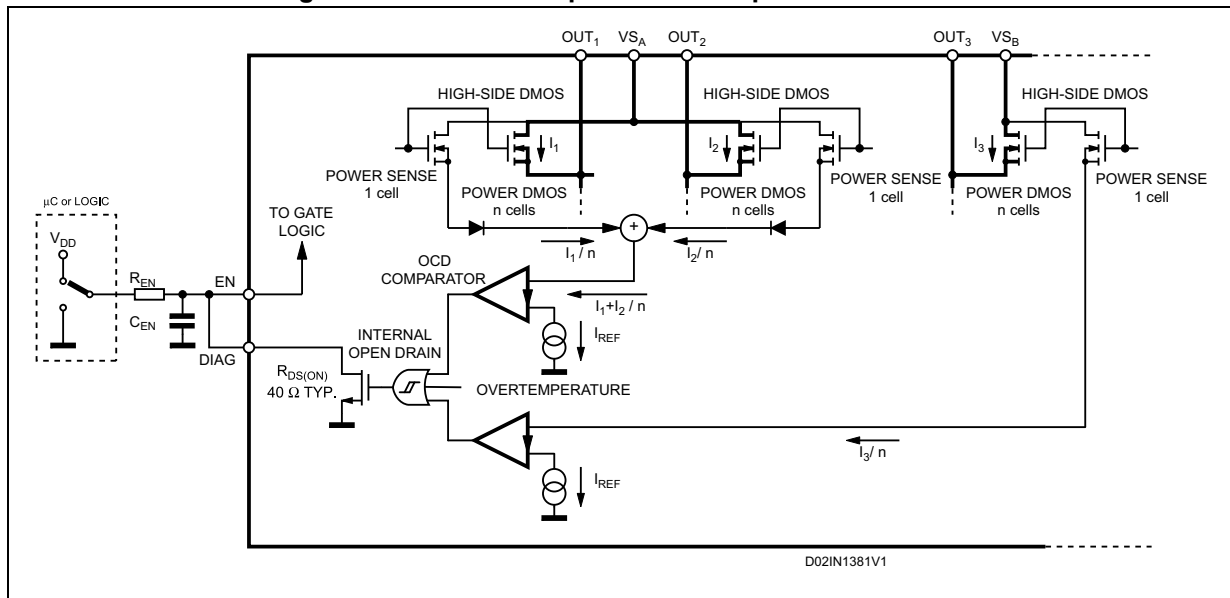

Figure 20 shows the overcurrent detection operation. The disable time $t_{DISABLE}$ before recovering normal operation can be easily programmed by means of the accurate thresholds of the logic inputs. It is affected whether by C_{EN} and R_{EN} values and its magnitude is reported in *Figure 21*. The delay time t_{DELAY} before turning off the bridge when an overcurrent has been detected depends only by C_{EN} value. Its magnitude is reported in *Figure 22*.

C_{EN} is also used for providing immunity to pin EN against fast transient noises. Therefore the value of C_{EN} should be chosen as big as possible according to the maximum tolerable delay time and the R_{EN} value should be chosen according to the desired disable time.

The resistor R_{EN} should be chosen in the range from 2.2 K Ω to 180 K Ω . Recommended values for R_{EN} and C_{EN} are respectively 100 K Ω and 5.6 nF that allow obtaining 200 μs disable time.

Figure 20. Overcurrent protection waveforms

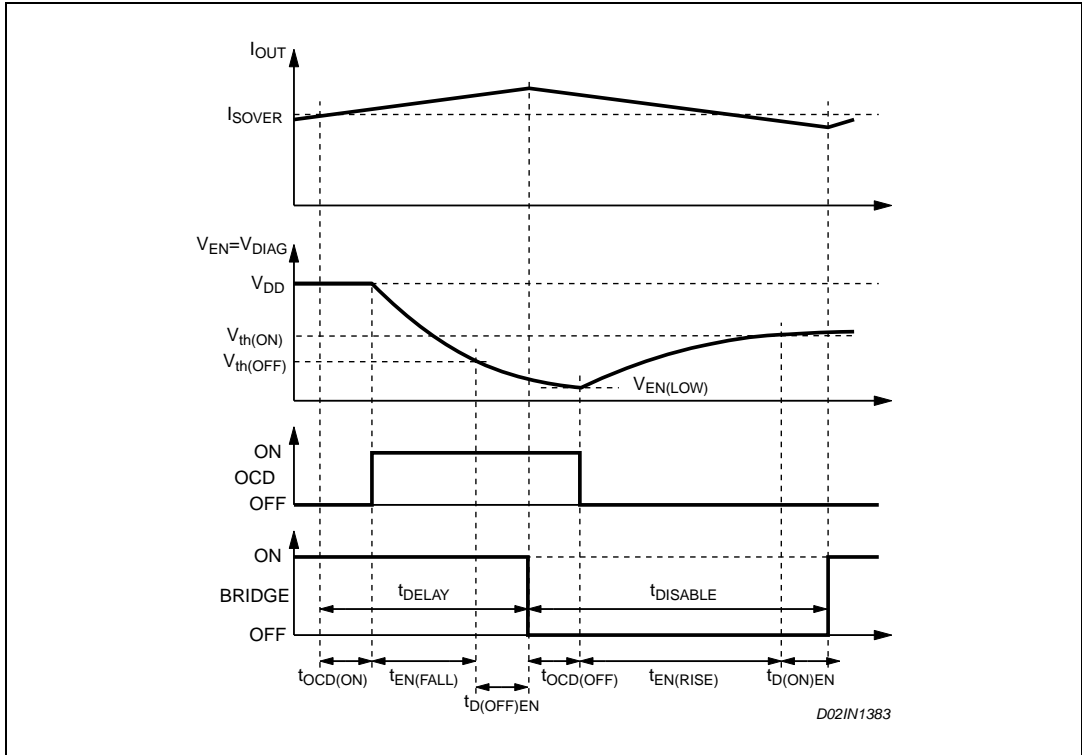

Figure 21. $t_{DISABLE}$ versus C_{EN} and R_{EN}

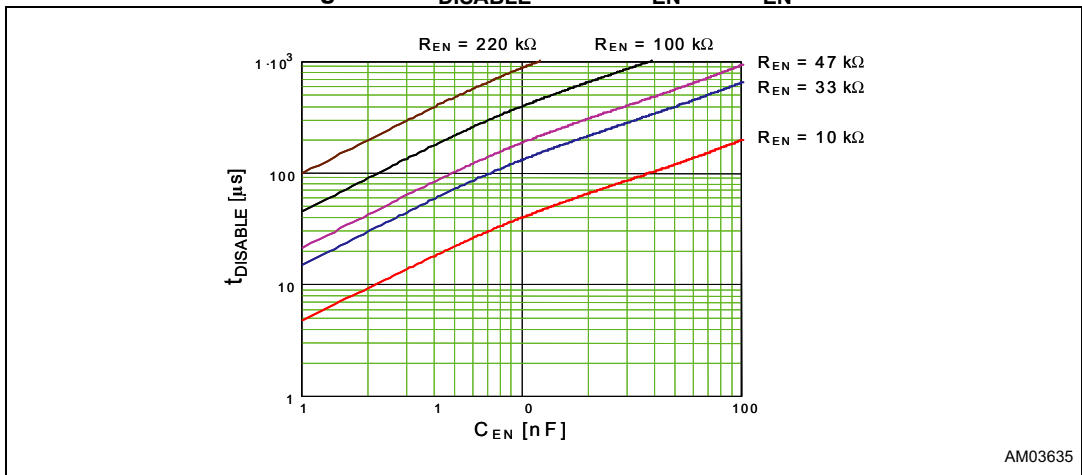
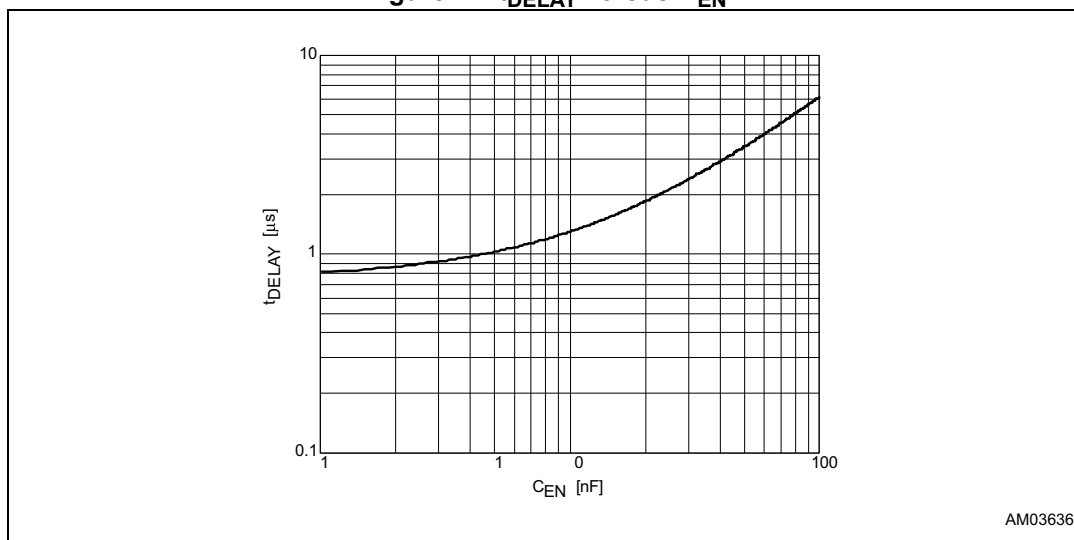

Figure 22. t_{DELAY} versus C_{EN}



11 Application information

A typical application using the L6235 device is shown in [Figure 23](#). Typical component values for the application are shown in [Table 8](#). A high quality ceramic capacitor (C_2) in the range of 100 nF to 200 nF should be placed between the power pins VS_A and VS_B and ground near the L6235 device to improve the high frequency filtering on the power supply and reduce high frequency transients generated by the switching. The capacitor (C_{EN}) connected from the EN input to ground sets the shutdown time when an overcurrent is detected (see [Section 10: Non-dissipative overcurrent detection and protection](#)). The two current sensing inputs ($SENSE_A$ and $SENSE_B$) should be connected to the sensing resistor R_{SENSE} with a trace length as short as possible in the layout. The sense resistor should be non-inductive resistor to minimize the di/dt transients across the resistor. To increase noise immunity, unused logic pins are best connected to 5 V (high logic level) or GND (low logic level) (see [Table 4: Pin description on page 6](#)). It is recommended to keep power ground and signal ground separated on the PCB.

Table 8. Component values for typical application

| Component | Value |
|--------------------------|----------------|
| C_1 | 100 μ F |
| C_2 | 100 nF |
| C_3 | 220 nF |
| C_{BOOT} | 220 nF |
| C_{OFF} | 1 nF |
| C_{PUL} | 10 nF |
| C_{REF1} | 33 nF |
| C_{REF2} | 100 nF |
| C_{EN} | 5.6 nF |
| C_P | 10 nF |
| D_1 | 1N4148 |
| D_2 | 1N4148 |
| R_1 | 5.6 K Ω |
| R_2 | 1.8 K Ω |
| R_3 | 4.7 K Ω |
| R_4 | 1 M Ω |
| R_{DD} | 1 K Ω |
| R_{EN} | 100 K Ω |
| R_P | 100 Ω |
| R_{SENSE} | 0.3 Ω |
| R_{OFF} | 33 K Ω |
| R_{PUL} | 47 K Ω |
| R_{H1}, R_{H2}, R_{H3} | 10 K Ω |

Figure 23. Typical application

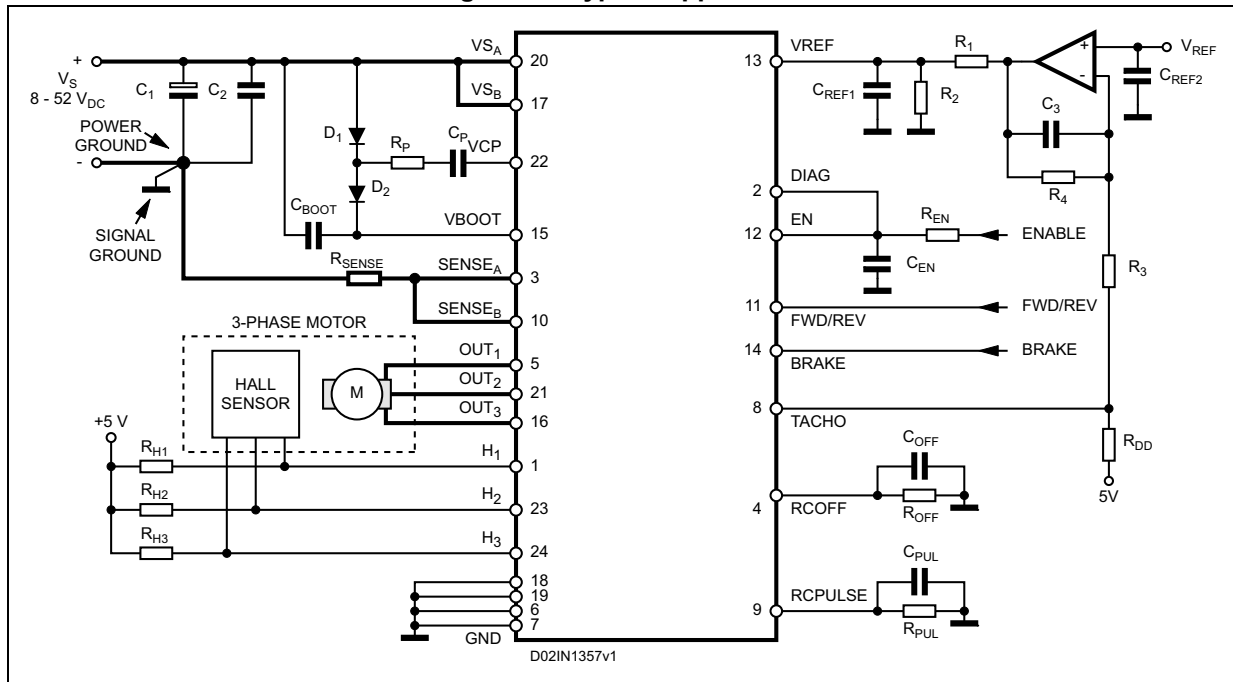

11.1 Output current capability and IC power dissipation

In [Figure 24](#) is shown the approximate relation between the output current and the IC power dissipation using PWM current control.

For a given output current the power dissipated by the IC can be easily evaluated, in order to establish which package should be used and how large must be the on-board copper dissipating area to guarantee a safe operating junction temperature (125 °C maximum).

Figure 24. IC power dissipation versus output power

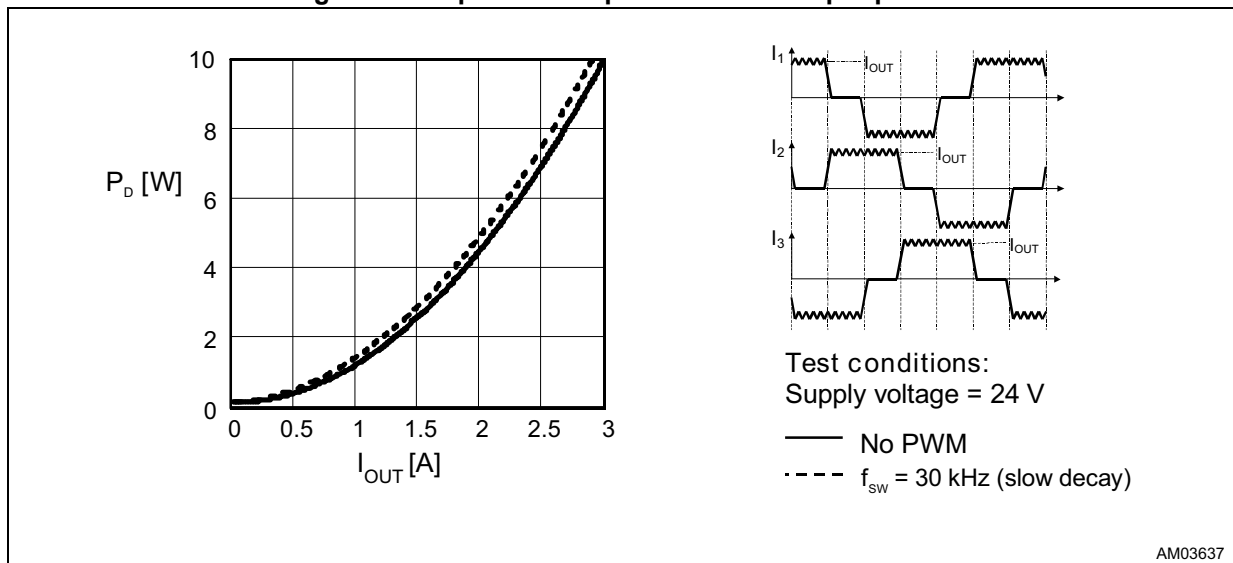

AM03637

11.2 Thermal management

In most applications the power dissipation in the IC is the main factor that sets the maximum current that can be delivered by the device in a safe operating condition. Selecting the appropriate package and heatsinking configuration for the application is required to maintain the IC within the allowed operating temperature range for the application. *Figure 25* and *26* show the junction to ambient thermal resistance values for the PowerSO36 and SO24 packages.

For instance, using a PowerSO package with a copper slug soldered on a 1.5 mm copper thickness FR4 board with a 6 cm² dissipating footprint (copper thickness of 35 μm), the $R_{th(j-amb)}$ is about 35 °C/W. *Figure 27* shows mounting methods for this package. Using a multilayer board with vias to a ground plane, thermal impedance can be reduced down to 15 °C/W.

Figure 25. PowerSO36 junction ambient thermal resistance versus on-board copper area

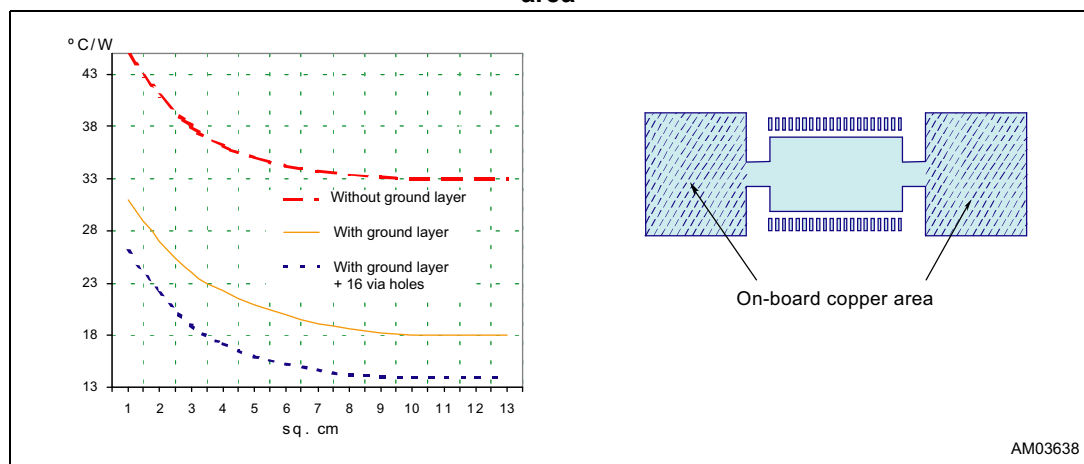

Figure 26. SO24 junction ambient thermal resistance versus on-board copper area

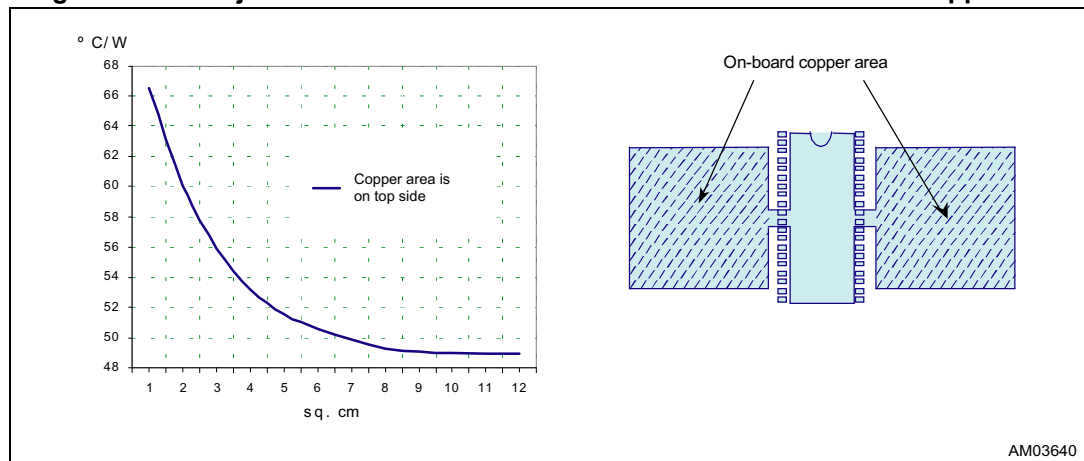

Figure 27. Mounting the PowerSO package

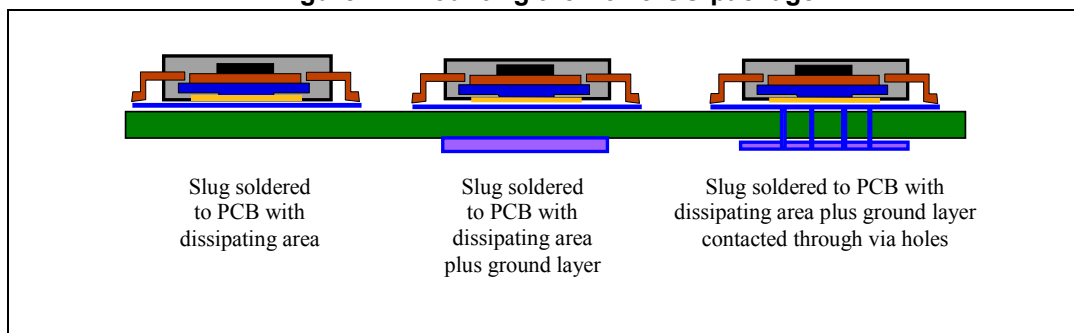

Figure 28. Typical quiescent current vs. supply voltage

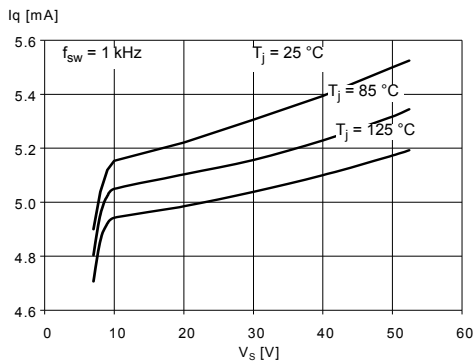

Figure 29. Typical high-side $R_{DS(ON)}$ vs. supply voltage

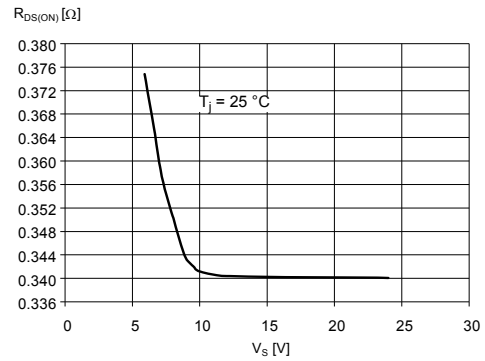

Figure 30. Normalized typical quiescent current vs. switching frequency

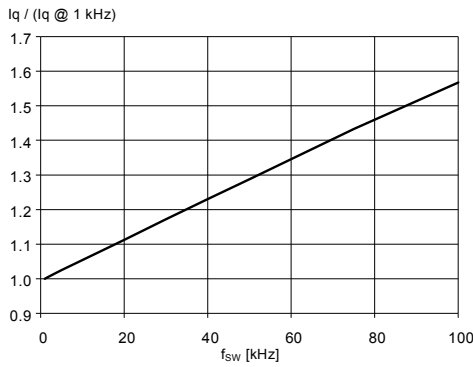

Figure 31. Normalized $R_{DS(ON)}$ vs. junction temperature (typical value)

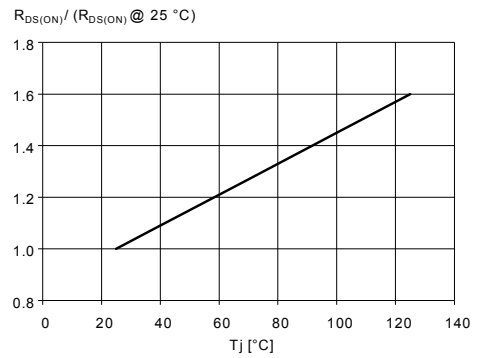

Figure 32. Typical low-side $R_{DS(ON)}$ vs. supply voltage

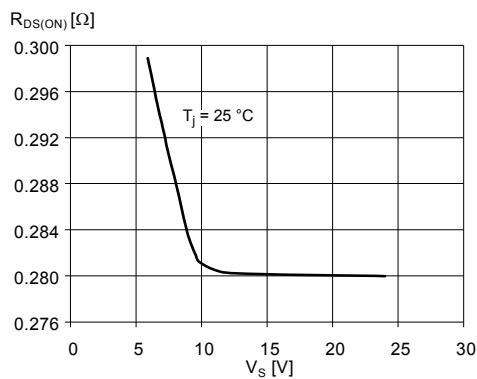
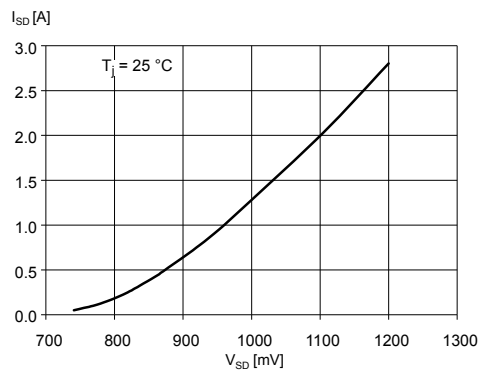

Figure 33. Typical drain-source diode forward ON characteristic



12 Package information

In order to meet environmental requirements, ST offers these devices in different grades of ECOPACK® packages, depending on their level of environmental compliance. ECOPACK specifications, grade definitions and product status are available at: www.st.com. ECOPACK is an ST trademark.

12.1 PowerSO36 package information

Figure 34. PowerSO36 package outline

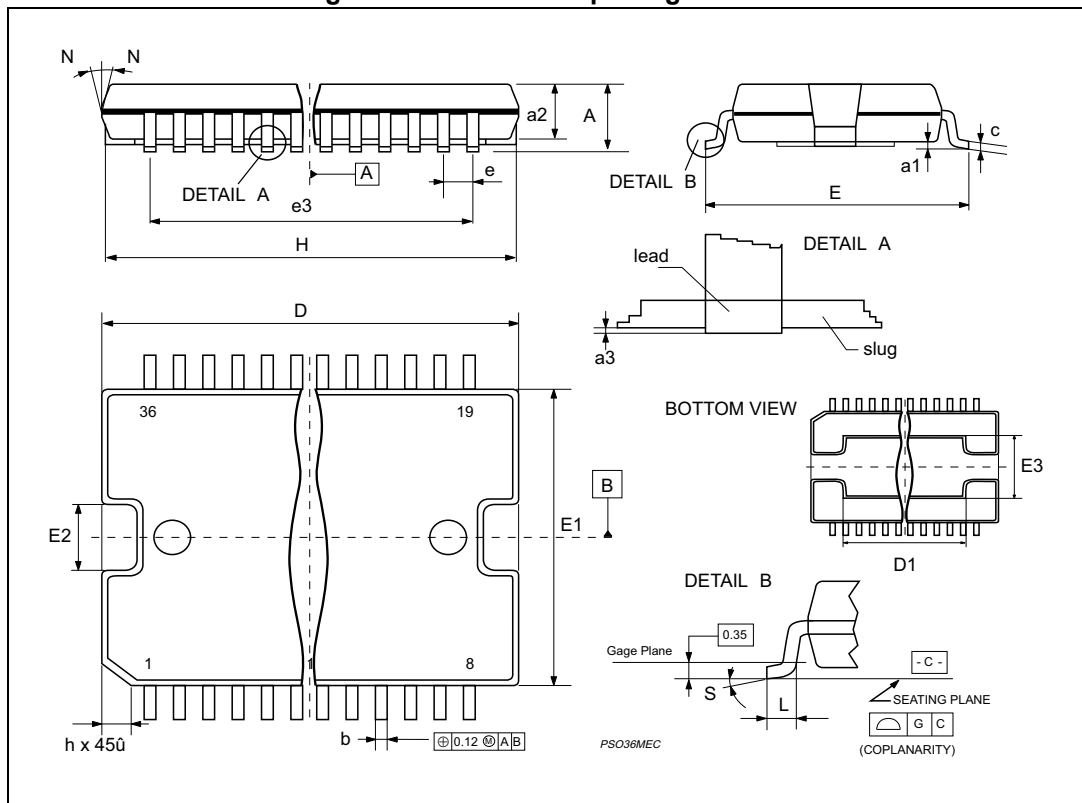

Table 9. PowerSO36 package mechanical data

| Symbol | Dimensions | | | | | |
|-------------------|------------|-------|-------|-------|--------|-------|
| | mm | | | inch | | |
| | Min. | Typ. | Max. | Min. | Typ. | Max. |
| A | - | - | 3.60 | - | - | 0.141 |
| a1 | 0.10 | - | 0.30 | 0.004 | - | 0.012 |
| a2 | - | - | 3.30 | - | - | 0.130 |
| a3 | 0 | - | 0.10 | 0 | - | 0.004 |
| b | 0.22 | - | 0.38 | 0.008 | - | 0.015 |
| c | 0.23 | - | 0.32 | 0.009 | - | 0.012 |
| D ⁽¹⁾ | 15.80 | - | 16.00 | 0.622 | - | 0.630 |
| D1 | 9.40 | - | 9.80 | 0.370 | - | 0.385 |
| E | 13.90 | - | 14.50 | 0.547 | - | 0.570 |
| e | - | 0.65 | - | - | 0.0256 | - |
| e3 | - | 11.05 | - | - | 0.435 | - |
| E1 ⁽¹⁾ | 10.90 | - | 11.10 | 0.429 | - | 0.437 |
| E2 | - | - | 2.90 | - | - | 0.114 |
| E3 | 5.80 | - | 6.20 | 0.228 | - | 0.244 |
| E4 | 2.90 | - | 3.20 | 0.114 | - | 0.126 |
| G | 0 | - | 0.10 | 0 | - | 0.004 |
| H | 15.50 | - | 15.90 | 0.610 | - | 0.626 |
| h | - | - | 1.10 | - | - | 0.043 |
| L | 0.80 | - | 1.10 | 0.031 | - | 0.043 |
| N | 10° (max.) | | | | | |
| S | 8° (max.) | | | | | |

1. "D" and "E1" do not include mold flash or protrusions.
 - Mold flash or protrusions shall not exceed 0.15 mm (0.006 inch).
 - Critical dimensions are "a3", "E" and "G".

12.2 SO24 package information

Figure 35. SO24 package outline

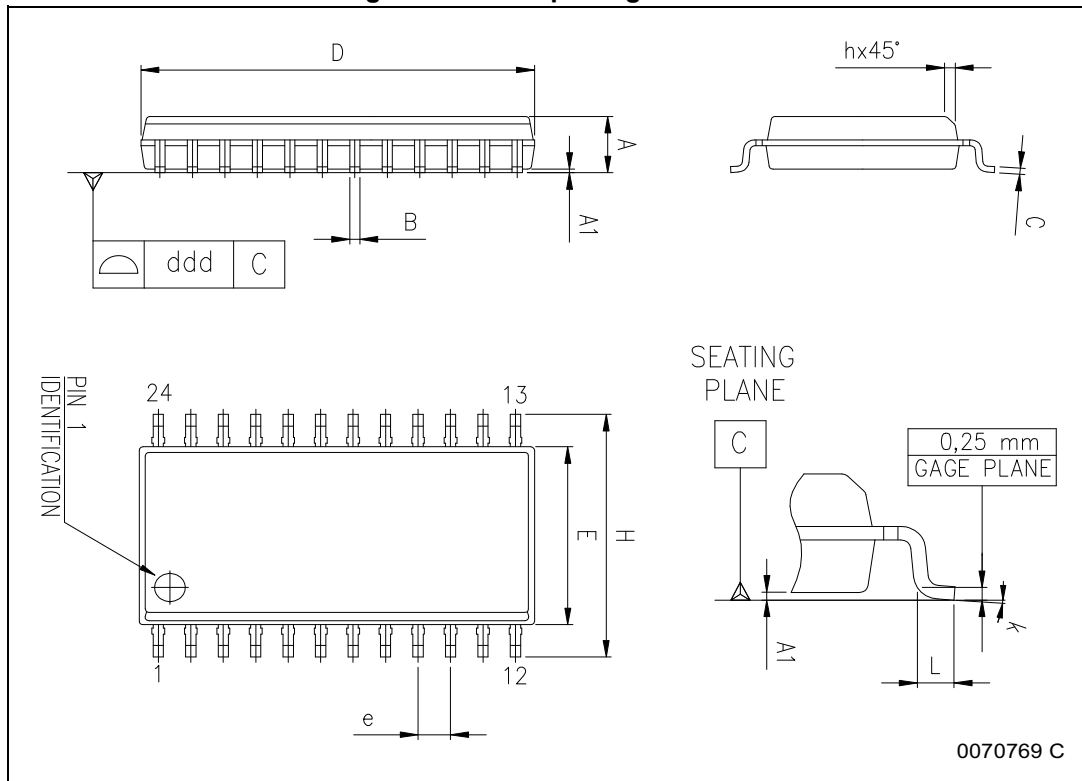

Table 10. SO24 package mechanical data

| Symbol | Dimensions (mm) | | | Dimensions (inch) | | |
|------------------|----------------------|------|-------|-------------------|-------|-------|
| | Min. | Typ. | Max. | Min. | Typ. | Max. |
| A | 2.35 | - | 2.65 | 0.093 | - | 0.104 |
| A1 | 0.10 | - | 0.30 | 0.004 | - | 0.012 |
| B | 0.33 | - | 0.51 | 0.013 | - | 0.020 |
| C | 0.23 | - | 0.32 | 0.009 | - | 0.013 |
| D ⁽¹⁾ | 15.20 | - | 15.60 | 0.598 | - | 0.614 |
| E | 7.40 | - | 7.60 | 0.291 | - | 0.299 |
| e | - | 1.27 | - | - | 0.050 | - |
| H | 10.0 | - | 10.65 | 0.394 | - | 0.419 |
| h | 0.25 | - | 0.75 | 0.010 | - | 0.030 |
| L | 0.40 | - | 1.27 | 0.016 | - | 0.050 |
| k | 0° (min.), 8° (max.) | | | | | |
| ddd | - | - | 0.10 | - | - | 0.004 |

1. "D" dimension does not include mold flash, protrusions or gate burrs. Mold flash, protrusions or gate burrs shall not exceed 0.15 mm per side.

13 Revision history

Table 11. Document revision history

| Date | Revision | Changes |
|-------------|----------|---|
| 03-Sep-2003 | 1 | Initial release. |
| 03-Mar-2014 | 2 | <p>Updated <i>Section : Description on page 1</i> (removed “MultiPower-” from “MultiPower-BCD technology”). Added <i>Contents on page 2</i>.</p> <p>Updated <i>Section 1 on page 3</i> (added section title, numbered and moved <i>Figure 1: Block diagram</i> from page 1 to page 3).</p> <p>Added title to <i>Section 2 on page 4</i>, added numbers and titles from <i>Table 1 to Table 3</i>.</p> <p>Added title to <i>Section 3 on page 6</i>, added number and title to <i>Figure 2</i>, renumbered note 1 below <i>Figure 2</i>, added title to <i>Table 4</i>.</p> <p>Added title to <i>Section 4 on page 8</i>, added title and number to <i>Table 5</i>, renumbered notes 1 to 4 below <i>Table 5</i>. Renumbered <i>Figure 3</i> and <i>Figure 4</i>.</p> <p>Added section numbers to <i>Section 5 on page 11</i>, <i>Section 5.1</i> and <i>Section 5.2</i>. Removed “and μC” from first sentence in <i>Section 5.2</i>. Renumbered <i>Table 6</i>, added header to <i>Table 6</i>. Renumbered <i>Figure 5</i> to <i>Figure 8</i>.</p> <p>Added section numbers to <i>Section 6 on page 13</i>. Renumbered <i>Figure 9</i> to <i>Figure 12</i>. Numbered <i>Equation 1</i> to <i>Equation 4</i>.</p> <p>Added section number to <i>Section 7 on page 17</i>. Renumbered <i>Figure 13</i>.</p> <p>Added section number to <i>Section 8 on page 18</i>. Renumbered <i>Table 7</i>. Renumbered <i>Figure 14</i> and <i>Figure 15</i>.</p> <p>Added section number to <i>Section 9 on page 20</i>. Renumbered <i>Figure 16</i> to <i>Figure 18</i>. Numbered <i>Equation 5</i> and <i>Equation 6</i>.</p> <p>Added section number to <i>Section 10 on page 22</i>. Renumbered <i>Figure 19</i> to <i>Figure 22</i>.</p> <p>Added section numbers to <i>Section 11 on page 25</i>, <i>Section 11.1</i> and <i>Section 11.2</i>. Renumbered <i>Table 8</i>, added header to <i>Table 8</i>. Renumbered <i>Figure 23</i> to <i>Figure 34</i>.</p> <p>Updated <i>Section on page 34</i> (added main title and ECOPACK text. Added titles from <i>Table 9</i> to <i>Table 11</i> and from <i>Figure 35</i> to <i>Figure 37</i>, reversed order of named tables and figures. Removed 3D figures of packages, replaced 0.200 by 0.020 inch of max. B value in <i>Table 11</i>).</p> <p>Added cross-references throughout document.</p> <p>Added <i>Section 13</i> and <i>Table 12</i>.</p> <p>Minor modifications throughout document.</p> |
| 15-Oct-2014 | 3 | <p>Updated <i>Table 5 on page 8</i> (replaced units “W” by “Ω”, updated cross-references to notes of I_{SOVER} and $t_{\text{OCD(OFF)}}$ symbols).</p> <p>Minor modifications throughout document.</p> |
| 04-Oct-2018 | 4 | <p>Removed PowerDIP24 package from the whole document.</p> <p>Removed “T_j” from <i>Table 2 on page 4</i>.</p> <p>Minor modifications throughout document.</p> |

IMPORTANT NOTICE – PLEASE READ CAREFULLY

STMicroelectronics NV and its subsidiaries (“ST”) reserve the right to make changes, corrections, enhancements, modifications, and improvements to ST products and/or to this document at any time without notice. Purchasers should obtain the latest relevant information on ST products before placing orders. ST products are sold pursuant to ST’s terms and conditions of sale in place at the time of order acknowledgement.

Purchasers are solely responsible for the choice, selection, and use of ST products and ST assumes no liability for application assistance or the design of Purchasers’ products.

No license, express or implied, to any intellectual property right is granted by ST herein.

Resale of ST products with provisions different from the information set forth herein shall void any warranty granted by ST for such product.

ST and the ST logo are trademarks of ST. All other product or service names are the property of their respective owners.

Information in this document supersedes and replaces information previously supplied in any prior versions of this document.

© 2018 STMicroelectronics – All rights reserved