

# **SPL16-001**

## **Digital pressure sensor**

Pb-free, halogen-free and RoHS compliant

**1. Security warning**

The information contained in this document is the exclusive property of Goermicro Inc. and should not be disclosed to any third party without the written consent of Goermicro Inc.

**2. Publication history**

Version	Date	Description	Author	Approved
1.0	2019.8.30	New design	Bruno	Devin
2.0	2019.9.10	Update product dimension	Bruno	Devin
3.0	2020.01.04	Update product dimension and Carrier Tape dimension	Tina	Bruno
4.0	2020.04.10	Update carrier tape Information	Tina	Bruno
5.0	2020.10.20	Update product dimension	Tina	Wiming
6.0	2021.01.30	Update product dimension	Tina	Wiming
7.0	2023.02.23	Add MSL and Reliability Specifications	Tina	Wiming

# Index of Contents

- 1. Introduction .....5**
- 2. Test condition.....6**
- 3. Absolute maximum ratings.....6**
- 4. Electrical characteristics.....6**
- 5. Operation .....8**
  - 5.1 Operating Modes .....8
  - 5.2 Measurement Precision and Rate .....8
  - 5.3 Sensor Interface.....9
  - 5.4 FIFO Operation .....10
  - 5.5 Calibration and Measurement Compensation .....10
    - 5.6.1 *How to Calculate Compensated Pressure Values.....10*
    - 5.6.2 *How to Calculate Compensated Temperature Values .....11*
    - 5.6.3 *Compensation Scale Factors.....12*
- 6. Applications.....13**
  - 6.1 Measurement Settings and Use Case Examples .....13
  - 6.2 Application Circuit Example.....14
  - 6.3 Calculating absolute altitude and calculating pressure at sea level .....14
- 7. Register Map.....16**
- 8. Register Description .....17**
  - 8.1 Pressure Data (PRS\_Bn).....17
    - 8.1.1 *PRS\_B2.....17*
    - 8.1.2 *PRS\_B1.....17*
    - 8.1.3 *PRS\_B0.....18*
  - 8.2 Temperature Data (TMP\_Bn) .....18
    - 8.2.1 *TMP\_B2.....18*
    - 8.2.2 *TMP\_B1.....19*
    - 8.2.3 *TMP\_B0.....19*
  - 8.3 Pressure Configuration (PRS\_CFG).....19
  - 8.4 Temperature Configuration (TMP\_CFG) .....21
  - 8.5 Sensor Operating Mode and Status (MEAS\_CFG).....22
  - 8.6 FIFO configuration (CFG\_REG) .....23
  - 8.7 FIFO Status (FIFO\_STS).....24
  - 8.8 Soft Reset and FIFO flush (RESET) .....25
  - 8.9 Product and Revision ID (ID) .....25
  - 8.10 Calibration Coefficients (COEF) .....26
- 9. Mechanical characteristics .....27**

9.1	Pin configuration .....	27
9.2	Outline dimensions .....	28
<b>10.</b>	<b>Storage and transportation.....</b>	<b>28</b>
<b>11.</b>	<b>Soldering recommendation .....</b>	<b>29</b>
<b>12.</b>	<b>Package Specifications .....</b>	<b>30</b>
<b>13.</b>	<b>Reliability Specifications.....</b>	<b>32</b>

## 1. Introduction

The SPL16-001 is a miniaturized Digital Barometric Air Pressure Sensor with a high accuracy and a low current consumption. The SPL16-001 is both a pressure and a temperature sensor. The pressure sensor element is based on a capacitive sensing principle which guarantees a high precision during temperature changes. The small package makes the SPL16-001 ideal for mobile applications and wearable devices. The SPL16-001's internal signal processor converts the output from the pressure and temperature sensor elements to 24-bit results. Each pressure sensor has been calibrated individually and contains calibration coefficients. The coefficients are used in the application to convert the measurement results to true pressure and temperature values.

The SPL16-001 has a FIFO that can store the latest 32 measurements. By using the FIFO, the host processor can remain in a sleep mode for a longer period of time between readouts. This can reduce the overall system power consumption. Sensor measurements and calibration coefficients are available through the serial I2C interface.

### Key features

- Pressure range: 300 ... 1100hPa (+9000m ... -500m relating to sea level)
- Temperature Range: -40...+85°C
- Supply voltage: 1.7 ... 3.6V (VDD), 1.2 ... 3.6V (VDDIO)
- Relative accuracy:  $\pm 0.06$ hPa, equiv. to  $\pm 0.5$  m
- Absolute accuracy: typ.  $\pm 1$ hPa (300 ... 1100hPa)
- Measurement time: Typical: 28 ms. Minimum: 3 ms.
- Average current consumption: High precision: 60  $\mu$ A, Low power: 3  $\mu$ A, Standby: <1  $\mu$ A.
- I2C interface, Embedded 24-bit ADC
- FIFO: Stores latest 32 pressure or temperature measurements.
- Pb-free, halogen-free and RoHS complian
- Water resistance degree: water resistance rating of 100 meters

### Typical applications

- Wearable devices
- Altimeter and barometer for portable devices
- Enhancement of GPS navigation (dead-reckoning, slope detection, etc.)
- In- and out-door navigation
- Weather station equipment
- Vertical velocity indication (rise/sink speed)

### Specific notes

Particles can influence the performance of the pressure sensor, we strongly recommend you to introduce special measures to avoid deposition of particles on the MEMS membrane or screen particles after assembly as the assembly process is considered to be the main root cause for particle generation.

## 2. Test condition

Table 1: Test condition

Standard Conditions	Temperature	Humidity	Air pressure
Environment conditions	-40°C...+85°C	25%RH...75%RH	300hPa...1100hPa
Basic test conditions	+25°C	60%RH...70%RH	300hPa...1100hPa

## 3. Absolute maximum ratings

Table 2: Absolute maximum ratings

Parameter	Condition	Min	Max	Units
Storage temperature		-40	+125	°C
Supply Voltage	All pins		+3.6	V
Voltage at all IO Pins	All pins		+3.6	V
ESD rating	JESD22-A114	-2	+2	kV
P <sub>water</sub> Overpressure			10000	hPa
<b>MSL</b>	<b>MSL 3</b>			

## 4. Electrical characteristics

VDD = 1.8V, VDDIO=1.8V, T=25°C, unless otherwise noted. If not stated otherwise, the given values are  $\pm 3$ -Sigma values over temperature/voltage range in the given operation mode.

Table 3: Operating conditions, output signal and mechanical characteristics

Parameter	Symbol	Condition		Min	Typ. <sup>(1)</sup>	Max	Units
Operating temperature	TA	Operational		-40	25	85	°C
		Full accuracy		0	25	65	°C
Operating Pressure	P			300		1100	hPa
Supply voltage	VDD			1.7		3.6	V
Interface supply voltage	VDDIO			1.2		3.6	V
Supply current (with 1 measurement per second.)	I <sub>dd</sub>	1 Hz	Low Power		3	5	uA
			Standard		11	15	
			High precision		40	50	
<p><i>Note: The current consumption depends on both pressure measurement precision and rate. Please refer to the <a href="#">Pressure Configuration (PRS_CFG)</a> register description for an overview of the current consumption in different combinations of measurement precision and rate.</i></p>							
Peak current	I <sub>peak</sub>	During conversion			400	500	uA

Standby current	Iddsbm				1	uA
Relative accuracy pressure	P_R	950...1050hPa		±6		Pa
		+25...+40°C		±0.5		m
Absolute accuracy pressure	P_A	300...1100hPa 0...+65°C	-3	±1	3	hPa
Resolution of output data		Pressure		0.06		Pa
		Temperature		0.01		°C
Noise in pressure	P_Noise	Low Power mode		5		PaRMS
		Standard mode		1.2		
		High precision mode		0.6		
<i>Note: Pressure noise is measured as the average standard deviation. Please refer to the <a href="#">Pressure Configuration (PRS_CFG)</a> register description for all precision mode options.</i>						
Offset temperature coefficient	TCO	1000hPa +25...+40°C		0.5		Pa/K
Absolute accuracy temperature		0...+65°C		±1		°C
Pressure/Temperature measurement rate	f		1		128	Hz
Pressure measurement time	t	Low Power mode		5	8	ms
		Standard mode		28	35	
		High precision mode		105	115	
<i>Note: The pressure measurement time (and thus the maximum rate) depends on the pressure measurement precision. Please refer to the <a href="#">Pressure Configuration (PRS_CFG)</a> register description for an overview of the possible combinations of measurement precision and rate.</i>						
Supply voltage ramp-up time	tvddup	Time for supply voltage to reach 90% of final value	0.001		5	ms
Serial data clock	f <sub>I2C</sub>	I2C			3.4	MHz
Long term stability		12month		1		hPa
Time to sensor ready	TSensor_rdy	The SENSOR_RDY bit in the Measurement Configuration register will be set when the sensor is ready			12	ms
Time to coefficients are available	TCoef_rdy	The COEF_RDY bit in the Measurement Configuration register will be set when the coefficients can be read out			40	ms

Note : (1) Typical specifications are not guaranteed.

## 5. Operation

### 5.1 Operating Modes

The SPL16-001 supports 3 different modes of operation: Standby, Command, and Background mode.

- Standby Mode
  - Default mode after power on or reset. No measurements are performed.
  - All registers and compensation coefficients are accessible.
- Command Mode
  - One temperature or pressure measurement is performed according to the selected precision.
  - The sensor will return to Standby Mode when the measurement is finished, and the measurement result will be available in the data registers.
- Background Mode
  - Pressure and/or temperature measurements are performed continuously according to the selected measurement precision and rate. The temperature measurement is performed immediately after the pressure measurement.
  - The FIFO can be used to store 32 measurement results and minimize the number of times the sensor must be accessed to read out the results.

*Note: Operation mode and measurement type are set in the [Sensor Operating Mode and Status \(MEAS\\_CFG\)](#) register.*

### 5.2 Measurement Precision and Rate

Different applications require different measurement precision and measurement rates. Some applications, like weather stations, require lower precision and measurement rates than for instance indoor navigation and sports applications.

The SPL16-001's measurement precision and rate (in background mode) can be configured to match the requirements of the application in which it is being used. This reduces current consumption of the sensor and the system.

In order to achieve a higher precision, the SPL16-001 will read the sensor multiple times (oversampling), and combine the readings into one result. This increases the current consumption and the measurement time, which again reduces the maximum measurement rate.

The measurement precision, rate and time is set in the [Pressure Configuration \(PRS\\_CFG\)](#) and [Temperature Configuration \(TMP\\_CFG\)](#) registers. The register descriptions contain information about the current consumption and the possible combinations of measurement precision, time, and rate.

Please note that the pressure sensor is temperature dependent. Temperature measurements must be made together with the pressure measurements in order to compensate for the temperature



dependency. This reduces the maximum pressure measurement rate, *since:  $Rate_{temperature} * Time_{temperature} + Rate_{pressure} * Time_{pressure} < 1 \text{ second}$* . Measurement Settings and Use Case Examples contains a table with examples of combinations of pressure and temperature precision and rates for different use cases.

### 5.3 Sensor Interface

The SPL16-001 can be accessed as a slave device through I2C serial interface

#### I2C interface

- The sensor's default interface.
- The sensor's address is *0x77*.

#### I2C write

Writing is done by sending the slave address in write mode (RW='0'), resulting in slave address 11101110. Then the master sends pairs of register addresses and register data. The transaction is ended by a stop condition.

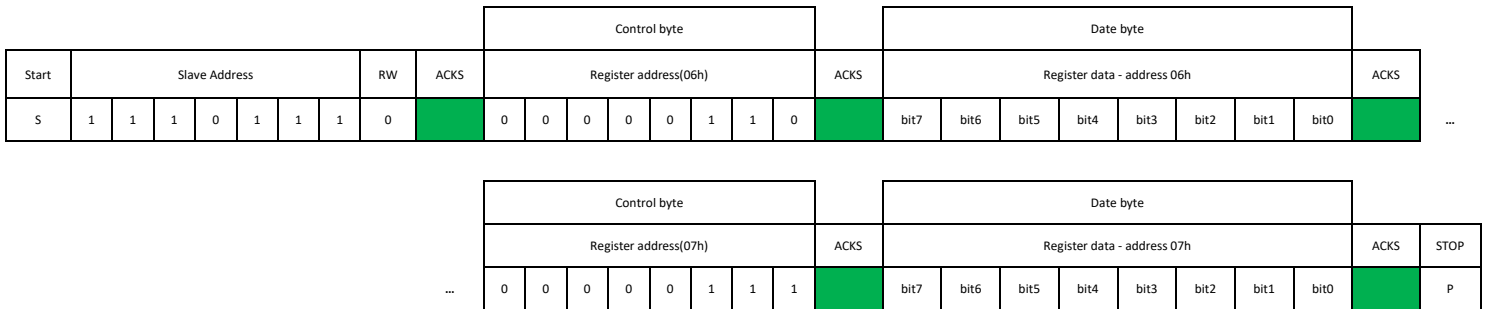

#### I2C read

To be able to read registers, first the register address must be sent in write mode (slave address 11101110). Then either a stop or a repeated start condition must be generated. After this the slave is addressed in read mode (RW='1') at address 11101111, after which the slave sends out data from auto-incremented register addresses until a NOACKM and stop condition occurs.



## 5.4 FIFO Operation

The SPL16-001 FIFO can store the last 32 measurements of pressure or temperature. This reduces the overall system power consumption when the host processor does not need to continuously pull data from the sensor but can go into standby mode for longer periods of time.

The FIFO will store any combination of temperature and pressure measurements since the measurement rate of temperature and pressure can be set up independently in Background Mode. The pressure rate can for instance be set 4 times higher than the temperature rate and thus only every fifth result will be a temperature result. The measurement type can be seen in the result data. The sensor will set the least significant bit to:

- '1' if the result is a pressure measurement.
  - '0' if it is a temperature measurement.
- The sensor uses 24 bits to store the measurement result. Because this is more bits than is needed to cover the full dynamic range of the pressure sensor, using the least significant bit to label the measurement type will not affect the precision of the result.

The FIFO can be enabled in the Interrupt and *FIFO configuration (CFG\_REG) register*. The data from the FIFO is read out from the *Pressure Data (PRS\_Bn) registers* regardless of the next result in the FIFO is a temperature or a pressure measurement.

When a measurement has been read out, the FIFO will auto increment and place the next result in the data register. A flag will be set in the *FIFO Status (FIFO\_STS) register* when the FIFO is empty and all following reads will return 0x800000.

If the FIFO runs full a flag will be set in the *FIFO Status (FIFO\_STS) register* and the sensor will generate an interrupt if this has been enabled in the Interrupt and *FIFO configuration (CFG\_REG) register*.

The FIFO will stop recording measurements results when it is full.

## 5.5 Calibration and Measurement Compensation

The SPL16-001 is a calibrated sensor and contains calibration coefficients. These are used in the application (for instance by the host processor) to compensate the measurement results for sensor non-linearity's.

The sections that follow, describe how to calculate the compensated results and convert them into Pa and °C values.

### 5.6.1 How to Calculate Compensated Pressure Values

1. Read the calibration coefficients (c00, c10, c20, c30, c01, c11, and c21) from the Calibration Coefficient register.

Note: The coefficients c00 and c10 are 20 bit 2's complement numbers, c20, c30, c01, c11 and c21 are 16 bit 2's complement numbers.

2. Choose scaling factors kT (for temperature) and kP (for pressure) based on the chosen precision rate. The scaling factors are listed in Table 4.

3. Read the pressure and temperature result from the registers or FIFO.

Note: The measurements read from the result registers (or FIFO) are 24 bit 2's complement numbers.

Depending on the chosen measurement rates, the temperature may not have been measured since the last pressure measurement.

4. Calculate scaled measurement results.

$$T_{raw\_sc} = T_{raw}/kT$$

$$P_{raw\_sc} = P_{raw}/kP$$

5. Calculate compensated measurement results.

$$P_{comp}(Pa) = c00 + P_{raw\_sc} * (c10 + P_{raw\_sc} * (c20 + P_{raw\_sc} * c30)) + T_{raw\_sc} * c01 + T_{raw\_sc} * P_{raw\_sc} * (c11 + P_{raw\_sc} * c21)$$

## 5.6.2 How to Calculate Compensated Temperature Values

1. Read the calibration coefficients ( c0 and c1 ) from the Calibration Coefficients (COEF) register.

Note: The coefficients read from the coefficient register are 12 bit 2's complement numbers.

2. Choose scaling factor kT (for temperature) based on the chosen precision rate. The scaling factors are listed in Table 4.

3. Read the temperature result from the temperature register or FIFO.

Note: The temperature measurements read from the temperature result register (or FIFO) are 24 bit 2's complement numbers.

4. Calculate scaled measurement results.

$$T_{raw\_sc} = T_{raw}/kT$$

5. Calculate compensated measurement results

$$T_{comp} (°C) = c0 * 0.5 + c1 * T_{raw\_sc}$$

### 5.6.3 Compensation Scale Factors

**Table 4 Compensation Scale Factors**

Oversampling Rate	Scale Factor (kP or kT)
1 (single)	524288
2 times (Low Power)	1572864
4 times	3670016
8 times	7864320
16 times (Standard)	253952
32 times	516096
64 times (High Precision)	1040384
128 times	2088960

## 6. Applications

### 6.1 Measurement Settings and Use Case Examples

**Table 5 Measurement Settings and Use Case Examples (TBD)**

Use Case	Performance	Pressure Register Configuration Address: 0x06	Temperature Register Configuration Address: 0x07	Other
Weather Station (Low power, Background mode)	5 Pa precision. 1 pr sec. 6 uA	0x01	0x80	Start background measurements (addr 0x08)
Indoor navigation (Standard precision, Background mode)	10 cm precision. 2 pr sec. 30 uA	0x14	0x80	Enable P shift (addr 0x09) Start background measurements (addr 0x08)
Sports (High precision, high rate, background mode)	5 cm precision 4 pr sec. 200 uA	0x26	0xA0	Enable P shift (addr 0x09) Start background measurements (addr 0x08)

## 6.2 Application Circuit Example

The example application circuit example uses the I2C serial interface.

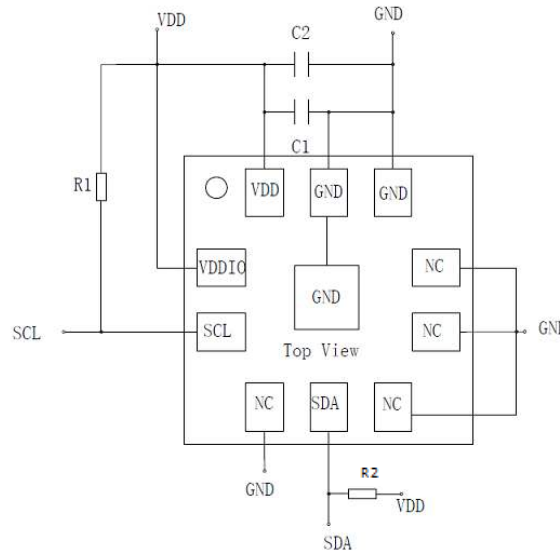

**Figure 1: Typical application circuit (top view)**

**Table 6 Component Values**

Component	Symbol	Values			Unit	Note / Test Condition
		Min.	Typ.	Max.		
Pull-up/down Resistor	R <sub>1</sub> , R <sub>2</sub>	2.2	4.7	10	KΩ	
Supply Blocking Capacitor	C <sub>1</sub>		100		nF	The blocking capacitors should be placed as close to the package pins as possible.
Supply Blocking Capacitor	C <sub>2</sub>		4.7		uF	The blocking capacitors should be placed as close to the package pins as possible.

## 6.3 Calculating absolute altitude and calculating pressure at sea level

With the measured pressure  $P$  and the pressure at sea level  $P_0=1013.25\text{hPa}$ , the altitude in meters can be calculated with the international barometric formula:

$$Altitude = 44330 \times \left[ 1 - \left( \frac{P}{P_0} \right)^{\frac{1}{5.255}} \right]$$

Thus, a pressure change of  $\Delta P = 1 \text{ hPa}$  corresponds to 8.43m at sea level.

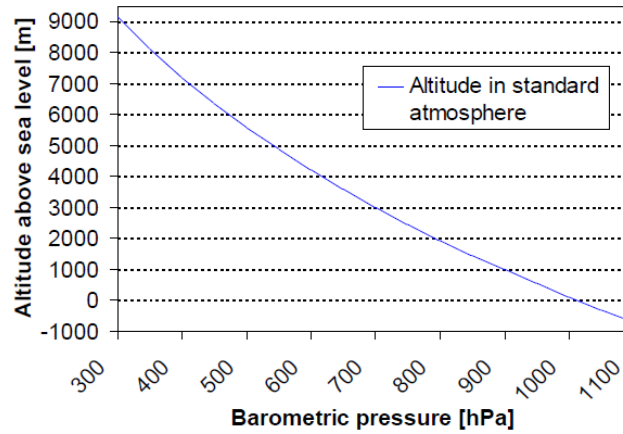

**Figure 2: Transfer function: Altitude over sea level – Barometric pressure**

With the measured pressure  $P$  and the absolute altitude the pressure at sea level can be calculated:

$$P_0 = \frac{P}{\left( 1 - \frac{altitude}{44330} \right)^{5.255}}$$

Thus, a difference in altitude of  $\Delta altitude = 10 \text{ m}$  corresponds to 1.2hPa pressure change at sea level.

## 7. Register Map

**Table 7 Register Map**

Register Name	Addr.	bit7	bit6	bit5	bit4	bit3	bit2	bit1	bit0	Reset State
PSR_B2	0x00	PSR[23:16] (r)								00h
PSR_B1	0x01	PSR[15:8](r)								00h
PSR_B0	0x02	PSR[7:0](r)								00h
TMP_B2	0x03	TMP[23:16] (r)								00h
TMP_B1	0x04	TMP[15:8] (r)								00h
TMP_B0	0x05	TMP[7:0] (r)								00h
PRS_CFG	0x06	-	PM_RATE [2:0] (rw)			PM_PRC [3:0] (rw)				00h
TMP_CFG	0x07	TMP_EXT (rw)	TMP_RATE [2:0] (rw)			-	TM_PRC [2:0] (rw)			00h
MEAS_CFG	0x08	COEF_RDY (r)	SENSOR_RDY (r)	TMP_RDY (r)	PRS_RDY (r)	-	MEAS_CRTL [2:0] (rw)			00h
CFG_REG	0x09	INT_HL (rw)	INT_SEL [2:0] (rw)			TMP_SHIFT_EN (rw)	PRS_SHIFT_EN (rw)	FIFO_EN (rw)	-	00h
FIFO_STS	0x0B	-	-	-	-	-	-	FIFO_FULL (r)	FIFO_EMPTY (r)	00h
RESET	0x0C	FIFO_FLUSH (w)	-	-	-	SOFT_RST [3:0] (w)				00h
ID	0x0D	PROD_ID [3:0] (r)				REV_ID [3:0] (r)				10h
COEF	0x10-0x21	< see register description >								XXh
Reserved	0x22-0x27	Reserved								XXh



## 8. Register Description

### 8.1 Pressure Data (PRS\_Bn)

The Pressure Data registers contains the 24 bit (3 bytes) 2's complement pressure measurement value. If the FIFO is enabled, the register will contain the FIFO pressure and/or temperature results (please see [FIFO Operation](#)). Otherwise, the register contains the pressure measurement results and will not be cleared after read.

#### 8.1.1 PRS\_B2

The highest byte of the three bytes measured pressure value.

PRS_B2	Address	00H
Pressure (MSB data)	Reset value:	00H
7	6	5
4	3	2
1	0	

PRS23	PRS22	PRS21	PRS20	PRS19	PRS18	PRS17	PRS16
r							

Field	Bits	Type	Description
PRS[23:16]	7:0	r	MSB of 24 bit 2's complement pressure data.

#### 8.1.2 PRS\_B1

The middle byte of the three bytes measured pressure value.

PRS_B1	Address	01H
Pressure (LSB data)	Reset value:	00H
7	6	5
4	3	2
1	0	

PRS15	PRS14	PRS13	PRS12	PRS11	PRS10	PRS9	PRS8-
r							

Field	Bits	Type	Description
PRS[15:8]	7:0	r	LSB of 24 bit 2's complement pressure data.

### 8.1.3 PRS\_B0

The lowest byte of the three bytes measured pressure value.

PRS_B0	Address	02H
Pressure (XLSB data)	Reset value:	00H
7	6	5
4	3	2
1	0	

PRS7	PRS6	PRS5	PRS4	PRS3	PRS2	PRS1	PRS0
------	------	------	------	------	------	------	------

r

Field	Bits	Type	Description
PRS[7:0]	7:0	r	XLSB of 24 bit 2’s complement pressure data.

## 8.2 Temperature Data (TMP\_Bn)

The Temperature Data registers contain the 24 bit (3 bytes) 2's complement temperature measurement value (unless the FIFO is enabled, please see [FIFO Operation](#)) and will not be cleared after the read.

### 8.2.1 TMP\_B2

The highest byte of the three bytes measured temperature value.

TMP_B2	Address	03H
Temperature (MSB data)	Reset value:	00H

7	6	5	4	3	2	1	0
---	---	---	---	---	---	---	---

TMP23	TMP22	TMP21	TMP20	TMP19	TMP18	TMP17	TMP16
-------	-------	-------	-------	-------	-------	-------	-------

r

Field	Bits	Type	Description
TMP[23:16]	7:0	r	MSB of 24 bit 2’s complement temperature data.

### 8.2.2 TMP\_B1

The middle byte of the three bytes measured temperature value.

TMP\_B1 Address 04H  
 Temperature (LSB data) Reset value: 00H

7      6      5      4      3      2      1      0

TMP15	TMP14	TMP13	TMP12	TMP11	TMP10	TMP9	TMP8
-------	-------	-------	-------	-------	-------	------	------

r

Field	Bits	Type	Description
TMP[15:8]	7:0	r	LSB of 24 bit 2's complement temperature data.

### 8.2.3 TMP\_B0

The lowest part of the three bytes measured temperature value.

TMP\_B0 Address 05H  
 Temperature (XLSB data) Reset value: 00H

7      6      5      4      3      2      1      0

TMP7	TMP6	TMP5	TMP4	TMP3	TMP2	TMP1	TMP0
------	------	------	------	------	------	------	------

r

Field	Bits	Type	Description
TMP[7:0]	7:0	r	XLSB of 24 bit 2's complement temperature data.

## 8.3 Pressure Configuration (PRS\_CFG)

Configuration of pressure measurement rate (PM\_RATE) and resolution (PM\_PRC).

PRS\_CFG Address: 06H  
 Pressure measurement configuration Reset value: 00H

7	6	5	4	3	2	1	0
-	PM_RATE[2:0]			PM_PRC[3:0]			

-

rw

rw

Field	Bits	Type	Description
-	7	-	Reserved.
PM_RATE[2:0]	6:4	rw	Pressure measurement rate: 000 - 1 measurements pr. sec. 001 - 2 measurements pr. sec. 010 - 4 measurements pr. sec. 011 - 8 measurements pr. sec. 100 - 16 measurements pr. sec. 101 - 32 measurements pr. sec. 110 - 64 measurements pr. sec. 111 - 128 measurements pr. sec. Applicable for measurements in Background mode only
PM_PRC[3:0]	3:0	rw	Pressure oversampling rate: 0000 - Single. 0001 - 2 times (Low Power). 0010 - 4 times. 0011 - 8 times. 0100 *)- 16 times (Standard). 0101 *) - 32 times. 0110 *) - 64 times (High Precision).

\*) Note: Use in combination with a bit shift. See [Interrupt and FIFO configuration \(CFG\\_REG\)](#) register

**Table 8 Pressure measurement time (ms) and precision (PaRMS)**

Oversampling (PRC[3:0])	Single (0000)	2 times (0001)	4 times (0010)	8 times (0011)	16 times (0100)	32 times (0101)	64 times (0110)
Measurement time (ms)	3.6	5.2	8.4	14.8	27.6	53.2	104.4
Precision (PaRMS)	5		2.5		1.2	0.9	0.5

**Table 9 Estimated current consumption (uA)**

Oversampling (PRC[3:0])	Single (0000)	2 times (0001)	4 times (0010)	8 times (0011)	16 times (0100)	32 times (0101)	64 times (0110)
Measurements pr sec.(PM_RATE([2:0])							
1 (000)	2.1	2.7	3.8	6.1	11	20	38
2 (001)							
4 (010)							
8 (011)	Note: The current consumption can be calculated as the Measurement Rate * Current Consumption of 1 measurement						
16 (100)							n.a.
32 (101)						n.a.	n.a.
64 (110)					n.a.	n.a.	n.a.
128 (111)			n.a.	n.a.	n.a.	n.a.	n.a.

*Note: The table shows the possible combinations of Pressure Measurement Rate and oversampling when no temperature measurements are performed. When temperature measurements are performed the possible combinations are limited to Rate<sub>temperature</sub> x Measurement Time<sub>temperature</sub> + Rate<sub>pressure</sub> x Measurement Time<sub>pressure</sub> < 1 second.*

### 8.4 Temperature Configuration (TMP\_CFG)

Configuration of temperature measurement rate (TMP\_RATE) and resolution (TMP\_PRC).

TMP\_CFG Address: 07H  
 Temperature measurement configuration Reset value: 00H

7          6          5          4          3          2          1          0

TMP_EX	TMP_RATE[2:0]	-	TMP_PRC[2:0]
rw	rw	-	rw

Field	Bits	Type	Description
TMP_EXT	7	rw	Temperature measurement 0 - Internal sensor (in ASIC) 1 - External sensor (in pressure sensor MEMS element) Note: This bit <b>must</b> be set to '1'.

TMP_RATE[2:0]	6:4	rw	Temperature measurement rate: 000 - 1 measurement pr. sec. 001 - 2 measurements pr. sec. 010 - 4 measurements pr. sec. 011 - 8 measurements pr. sec. 100 - 16 measurements pr. sec. 101 - 32 measurements pr. sec. 110 - 64 measurements pr. sec. 111 - 128 measurements pr. sec. Applicable for measurements in Background mode only
-	3	-	Reserved.
TMP_PRC[2:0]	2:0	rw	Temperature oversampling (precision): 000 - single. (Default) - Measurement time 3.6 ms. Note: Following are optional, and may not be relevant: 001 - 2 times. 010 - 4 times. 011 - 8 times. 100 - 16 times. 101 - 32 times. 110 - 64 times.

### 8.5 Sensor Operating Mode and Status (MEAS\_CFG)

Setup measurement mode.

MEAS_CFG	Address	08H					
Measurement configuration	Reset value:	00H					
7	6	5	4	3	2	1	0

COEF_RDY	SENSOR_RDY	TMP_RDY	PRS_RDY	-	MEAS_CTRL
r	r	r	r	-	rw
Field	Bits	Type	Description		
COEF_RDY	7	r	Coefficients will be read to the Coefficients Registers after start- up: 0 - Coefficients are not available yet. 1 - Coefficients are available.		

SENSOR_RDY	6	r	The pressure sensor is running through self-initialization after start-up. 0 - Sensor initialization not complete 1 - Sensor initialization complete It is recommend not to start measurements until the sensor has completed the self-initialization.
TMP_RDY	5	r	Temperature measurement ready 1 - New temperature measurement is ready. Cleared when temperature measurement is read.
PRS_RDY	4	r	Pressure measurement ready 1 - New pressure measurement is ready. Cleared when procurement measurement is read.
-	3	-	Reserved.
MEAS_CTRL	2:0	rw	Set measurement mode and type: Standby Mode 000 - Idle / Stop background measurement Command Mode 001 - Pressure measurement 010 - Temperature measurement 011 - na. 100 - na. Background Mode 101 - Continuous pressure measurement 110 - Continuous temperature measurement 111 - Continuous pressure and temperature measurement

### 8.6FIFO configuration (CFG\_REG)

Configuration of interrupts, measurement data shift, and FIFO enable.

CFG\_REG Address 09H  
Configuration register Reset value: 00H

7 6 5 4 3 2 1 0

-	-	-	-	T_SHIFT	P_SHIFT	FIFO_EN	-
-	-	-	-	rw	rw	rw	-

Field	Bits	Type	Description
-	7:4	-	-
T_SHIFT	3	rw	Temperature result bit-shift 0 - no shift. 1 - shift result right in data register. Note: Must be set to '1' when the oversampling rate is >8 times.
P_SHIFT	2	rw	Pressure result bit-shift 0 - no shift. 1 - shift result right in data register. Note: Must be set to '1' when the oversampling rate is >8 times.
FIFO_EN	1	rw	Enable the FIFO: 0 - Disable. 1 - Enable.
-	0	-	-

### 8.7 FIFO Status (FIFO\_STS)

FIFO status register

FIFO_STS	Address	0BH
FIFO status register	Reset value:	00H

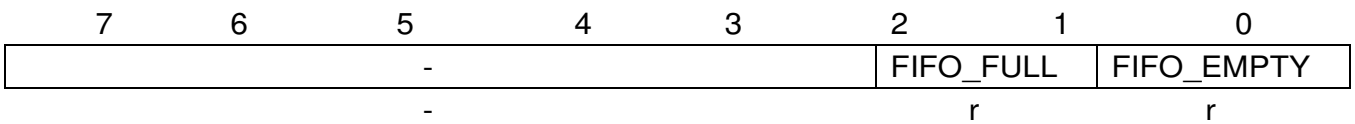

Field	Bits	Type	Description
-	7:2	-	Reserved.
FIFO_FULL	1	r	0 - The FIFO is not full 1 - The FIFO is full
FIFO_EMPTY	0	r	0 - The FIFO is not empty 1 - The FIFO is empty



### 8.8 Soft Reset and FIFO flush (RESET)

Flush FIFO or generate soft reset.

RESET Address: 0CH  
 FIFO flush and soft reset Reset value: 00H

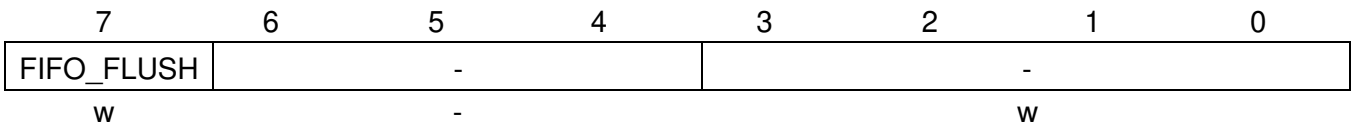

Field	Bits	Type	Description
FIFO_FLUSH	7	w	FIFO flush 1 - Empty FIFO After reading out all data from the FIFO, write '1' to clear all old data.
-	6:4	-	Reserved.
SOFT_RST	3:0	w	Write '1001' to generate a soft reset. A soft reset will run through the same sequences as in power-on reset.

### 8.9 Product and Revision ID (ID)

Product and Revision ID.

ID Address: 0DH  
 Product and revision ID Reset value: 0x10H

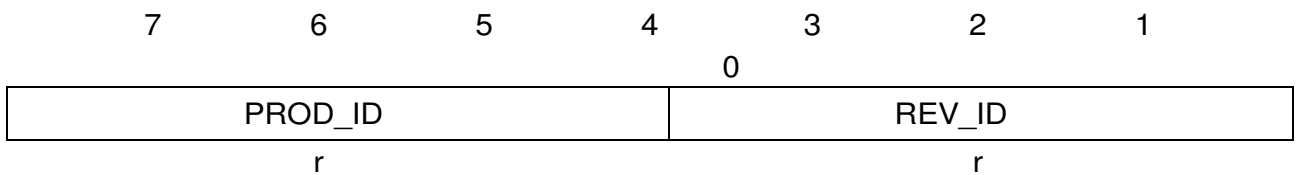

Field	Bits	Type	Description
PROD_ID	7:4	r	Product ID
REV_ID	3:0	r	Revision ID

## 8.10 Calibration Coefficients (COEF)

The Calibration Coefficients register contains the 2’s complement coefficients that are used to calculate the compensated pressure and temperature values.

**Table 10 Calibration Coefficients**

Coefficient	Addr.	bit7	bit6	bit5	bit4	bit3	bit2	bit1	bit0
c0	0x10	c0 [11:4]							
c0/c1	0x11	c0 [3:0]				c1 [11:8]			
c1	0x12	c1[7:0]							
c00	0x13	c00 [19:12]							
c00	0x14	c00 [11:4]							
c00/c10	0x15	c00 [3:0]				c10 [19:16]			
c10	0x16	c10 [15:8]							
c10	0x17	c10 [7:0]							
c01	0x18	c01 [15:8]							
c01	0x19	c01 [7:0]							
c11	0x1A	c11 [15:8]							
c11	0x1B	c11 [7:0]							
c20	0x1C	c20 [15:8]							
c20	0x1D	c20 [7:0]							
c21	0x1E	c21 [15:8]							
c21	0x1F	c21 [7:0]							
c30	0x20	c30 [15:8]							
c30	0x21	c30 [7:0]							

## 9. Mechanical characteristics

### 9.1 Pin configuration

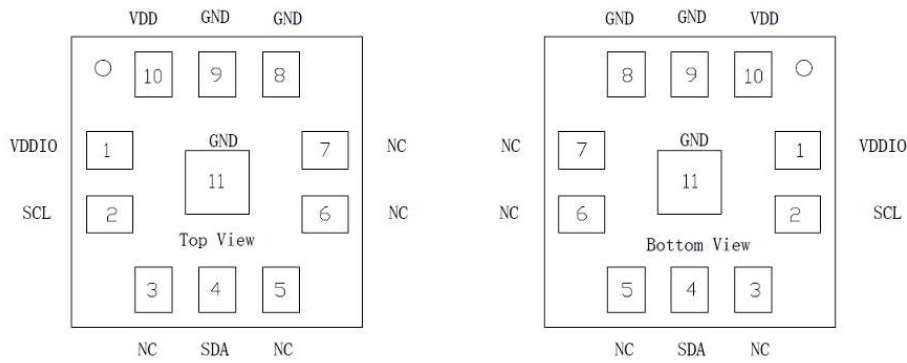

Figure 3: Layout pin configuration SPL16-001 (bottom and top view)

Table 11: Pin configuration of SPL16-001

Pin	Name	I2C
1	VDDIO	Digital supply voltage for digital blocks and I/O interface
2	SCL	Serial Clock
3	NC	Not Connected
4	SDA	Serial data in/out
5	NC	Not Connected
6	NC	Not Connected
7	NC	Not Connected
8	GND	Ground
9	GND	Ground
10	VDD	Supply voltage for analog blocks
11	GND	Ground

## 9.2 Outline dimensions

The sensor housing is a 11-Pin LGA package with potting gel. Its dimensions are 2.70mm ( $\pm 0.15$  mm)  $\text{©} \times 2.70$ mm ( $\pm 0.15$  mm)  $\text{©} \times 1.70$ mm ( $\pm 0.15$ mm)  $\text{©}$ , undeclared tolerance ( $\pm 0.05$ mm).

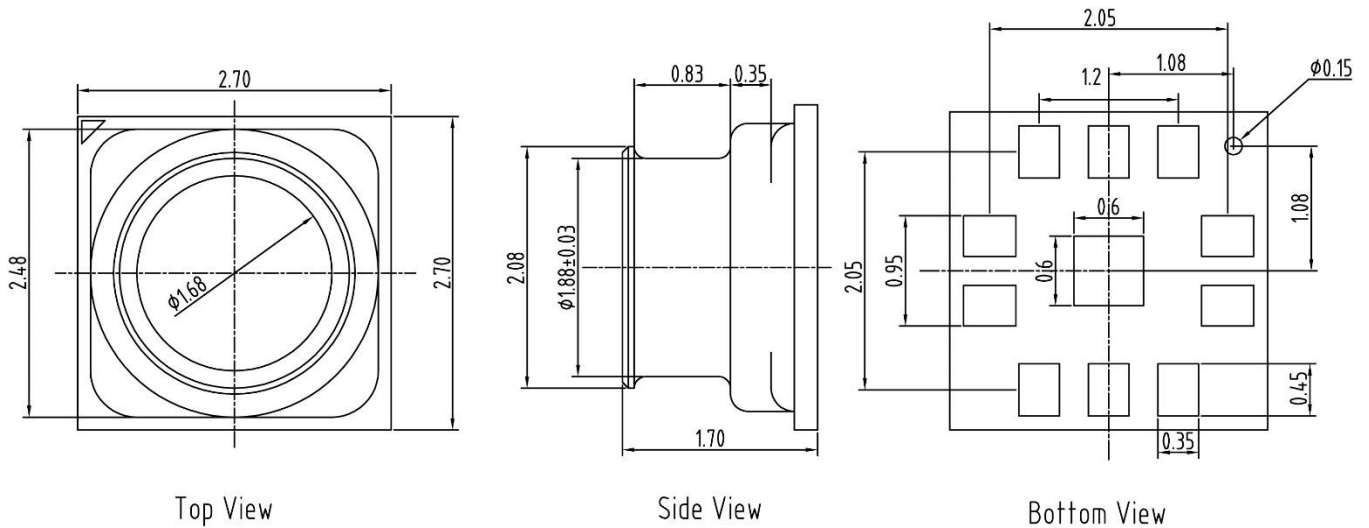

Figure 4: SPL16-001 outline and mechanical data

## 10. Storage and transportation

- Keep in warehouse with less than 75% humidity and without sudden temperature change, acid air, any other harmful air or strong magnetic field.
- The MEMS pressure sensor with normal pack can be transported by ordinary conveyances. Please protect products against moist, shock, sunburn and pressure during transportation.
- Storage Temperature Range:  $-40^{\circ}\text{C} \sim +125^{\circ}\text{C}$
- Operating Temperature Range:  $-40^{\circ}\text{C} \sim +85^{\circ}\text{C}$

## 11. Soldering recommendation

Recommended Solder Reflow

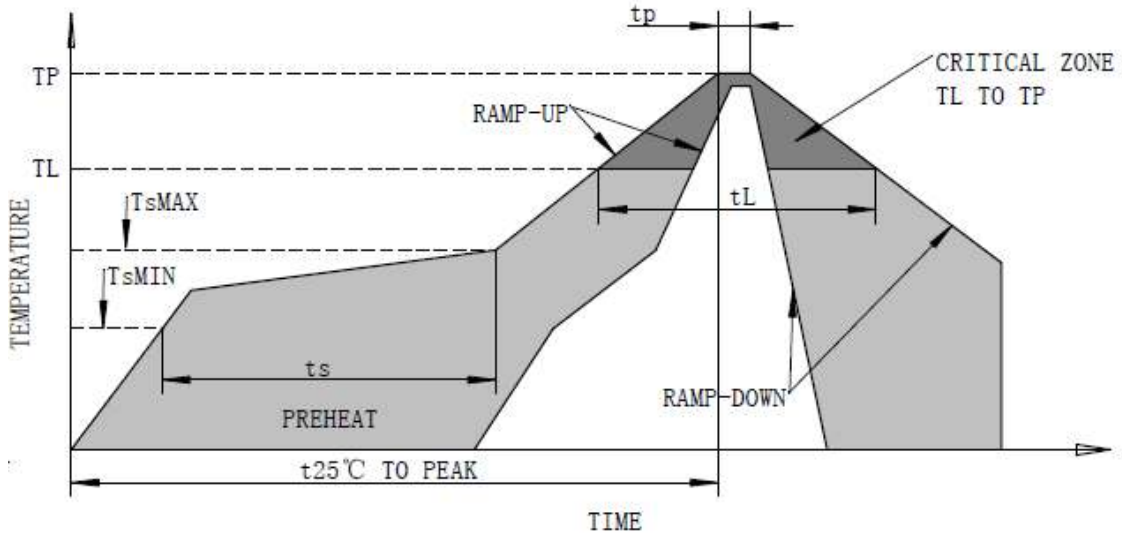

Profile Feature	Pb-Free Assembly
Average ramp-up rate(TsMAX to TP)	2°C /seconds max.
Preheat	
-Temperature Min.(TsMIN)	130°C
-Temperature Max.(TsMAX)	200°C
-Time(TsMIN to TsMAX)(Ts)	90~110seconds
Time maintained above:	
-Temperature(TL)	217°C
-Time(tL)	50~60seconds
Ramp time of Ts to TL	15-25 seconds
Time 25°C to peak temperature	300 seconds max
Peak temperature(TP)	235-240 °C
Ramp-down rate(peak to 217°C)	2~4°C /seconds

## 12. Package Specifications

Carrier Tape Information [Unit: mm]

Quantity per reel: 3.5 kpcs.

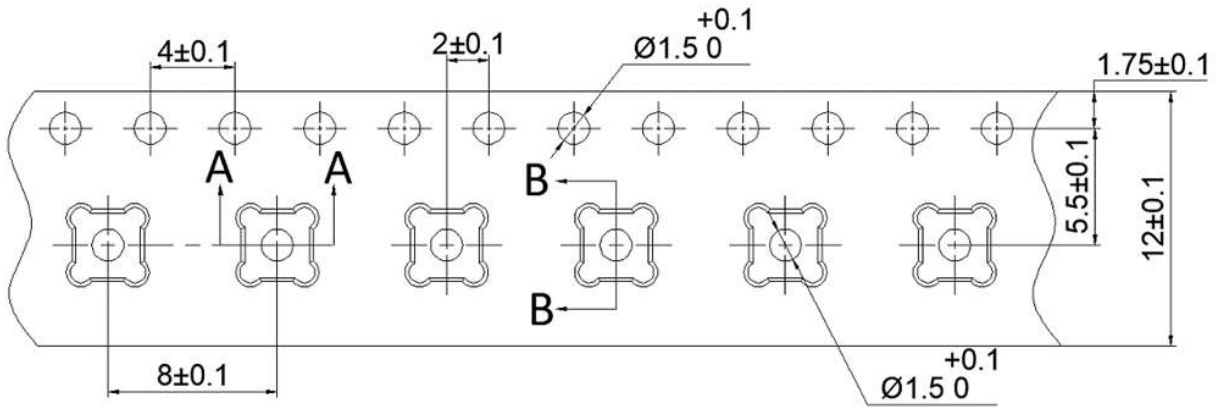

A-A 2:1

B-B 2:1

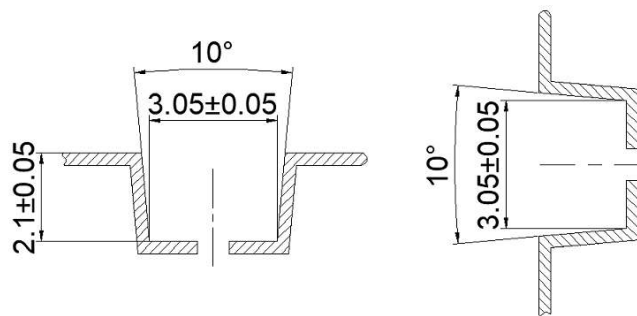

Figure 5: Carrier tape dimensions

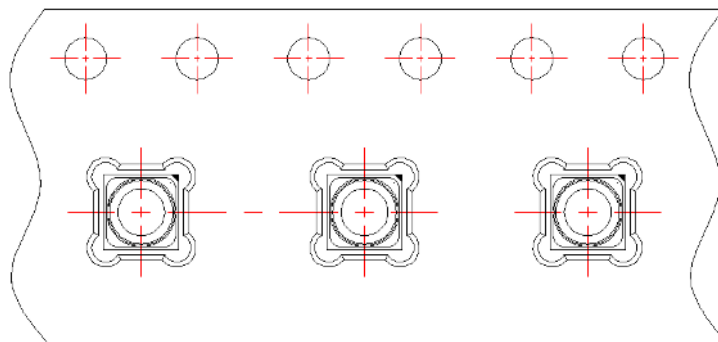

Figure 6: Orientation within carrier tape

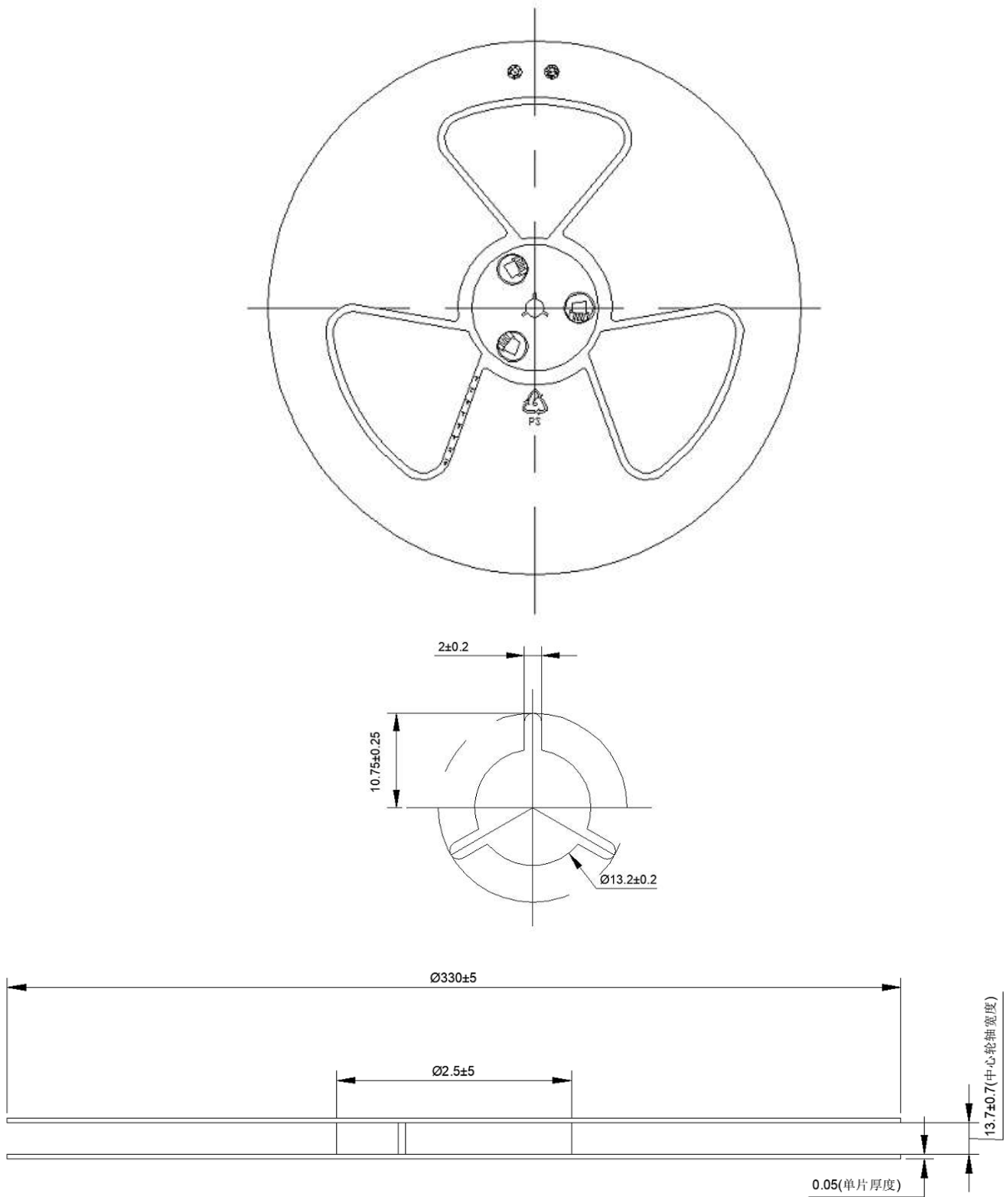

Figure 7: Carrier Tape reel dimensions

### 13. Reliability Specifications

NO.	Testing Item	Test Condition
1	High Temperature Storage	125°C,1000h (JESD22-A103)
2	High Temperature & Humidity Test	85°C, 85%R.H., 1000h, V=Vcc max (JESD22-A101)
3	Thermal Shock Test	-40°C/0.5 hours ~125°C/0.5 hours, 500 cycles (JESD22-A106)
4	Mechanical Shock Test	3000g,0.3ms,6axes*3 times (JESD22-B110)
5	Vibration Test	From 20 to 2000Hz peak acceleration 20g,16min/axis(4 cycles),X,Y and Z axis total 48 minutes (JESD22-B103)
6	HBM	±2KV,3 times for each pad (JESD22-A114)