

# MGA-675T6

## Low Noise Amplifier with Shutdown Mode in Low Profile Package for 4.9 – 6 GHz Application



### Data Sheet

#### Description

Avago Technologies' MGA-675T6 is an economical, easy-to-use wideband GaAs MMIC Low Noise Amplifier (LNA) with Shutdown mode. The LNA has low noise and high linearity achieved through the use of Avago Technologies' proprietary 0.5um GaAs Enhancement-mode pHEMT process. The shutdown mode enables the LNA to be turned off when not in use and reduce current consumption. It is housed in a low profile 2 x 1.3 x 0.4mm 6-pin Ultra Thin Package. The compact footprint and low profile coupled with low noise, high linearity makes the MGA-675T6 an ideal choice as a low noise amplifier for mobile receiver in the WLAN applications.

#### Component Image

2.0 x 1.3 x 0.4 mm<sup>3</sup> 6-lead Ultra Thin Package

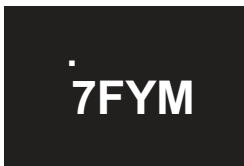

Top View

Note:  
Package marking provides orientation and identification  
"7F" = Product Code  
"Y" = Year of Manufacture  
"M" = Month of Manufacture

#### Pin Configuration

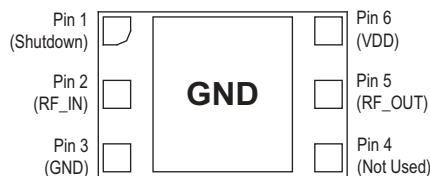

Top View

#### Features

- Low operating current
- Low Noise Figure
- 4.9 GHz – 6 GHz operating range
- GaAs E-pHEMT Technology<sup>[1]</sup>
- Best in class linearity and input power compression
- Low profile package size: 2.0 x 3.0 x 0.4 mm<sup>3</sup>
- Excellent uniformity in product specifications
- Tape-and-Reel packaging option available

#### Specifications

5.5 GHz; 3V, 10mA (typ):

- 17.8 dB Gain
- 1.75 dB Noise Figure
- -3 dBm Input IP3
- -10 dBm Input Power at 1dB gain compression
- S11 of -8.5dB, S22 of -9dB for NF match.
- <0.5mA current consumption in Shutdown Mode

#### Applications

- Low noise amplifier for mobile receiver for WLAN.
- Other ultra low noise application in the 4.9 – 6 GHz band e.g 5.8 GHz WiMax.

Note:  
1. Enhancement mode technology employs positive Vgs, thereby eliminating the need of negative gate voltage associated with conventional depletion mode devices.



**Attention: Observe precautions for handling electrostatic sensitive devices.**  
ESD Machine Model = 50V  
ESD Human Body Model = 250V  
Refer to Avago Application Note A004R: *Electrostatic Discharge, Damage and Control.*

## Absolute Maximum Ratings <sup>[1]</sup> T<sub>A</sub> = 25 °C

Symbol	Parameter	Units	Absolute Max.
V <sub>dd</sub>	Device Voltage	V	3.6
P <sub>in,max</sub>	CW RF Input Power	dBm	12
P <sub>diss</sub>	Total Power Dissipation	mW	45
T <sub>j</sub>	Junction Temperature	°C	150
T <sub>STG</sub>	Storage Temperature	°C	-65 to 150

## Thermal Resistance [2,3]

(V<sub>dd</sub> = 3.0V, I<sub>d</sub> = 10mA) , θ<sub>jc</sub> = 65 °C/W

Notes:

1. Operation of this device in excess of any of these limits may cause permanent damage.
2. Thermal resistance measured using Infra-Red Measurement Technique.
3. Board temperature T<sub>B</sub> is 25 °C , for T<sub>B</sub> > 147 °C, Derate the device power at 15.4 mW per °C rise in board ( Package belly) temperature.

## Electrical Specifications<sup>[4,5]</sup>

T<sub>A</sub> = 25 °C, V<sub>dd</sub> = V<sub>shutdown</sub> = 3V @ 10mA, RF performance at 5.5 GHz, measured on demo board (see Figure 4) unless otherwise specified.

Symbol	Parameter and Test Condition	Units	Min.	Typ.	Max.
V <sub>dd</sub>	Supply Voltage	V		3	
V <sub>Shutdown</sub>	Shutdown Voltage	V		3	
I <sub>ds</sub>	Supply Current	mA	6.8	10	13
Gain	Gain	dB	16.3	17.8	19.3
IIP3 <sup>[5]</sup>	Input Third Order Intercept Point	dBm	-	-3	-
NF	Noise Figure	dB	-	1.75	2.1
IP1dB	Input Power at 1dB Gain Compression	dBm	-	-10	-
S11	Input Return Loss, 50Ω source	dB	-	-8.5	-
S22	Output Return Loss, 50Ω load	dB	-	-9	-

Notes:

4. Measurements at 5.5GHz obtained using demo board described in Figure 1.
5. LNA Mode IIP3 test condition: F<sub>RF1</sub> = 5.5 GHz, F<sub>RF2</sub> = 5.505 GHz with input power of -30dBm per tone.

## The LNA operation configuration

	V <sub>dd</sub>	V <sub>Shutdown</sub>
LNA Mode	3V	3V
Shutdown Mode	3V	0V

## Product Consistency Distribution Charts<sup>[1]</sup>

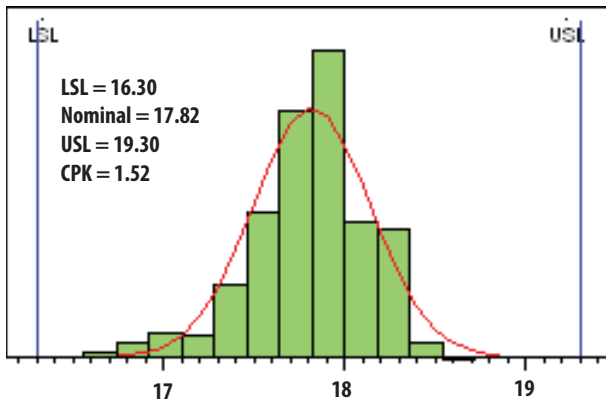

Figure 1. Gain @ 5.5 GHz, Vd 3V; Vshutdown 3 V

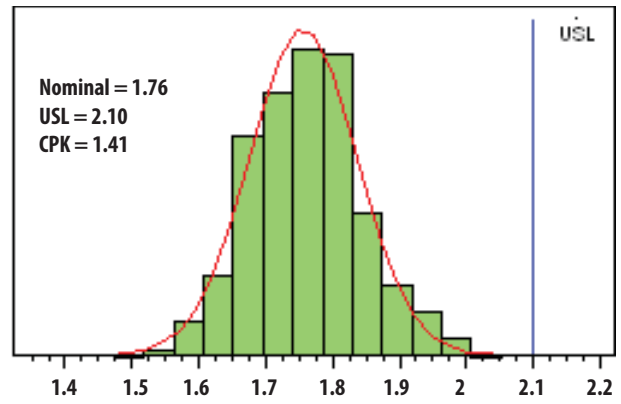

Figure 2. NF @ 5.5 GHz, Vd 3V; Vshutdown 3 V

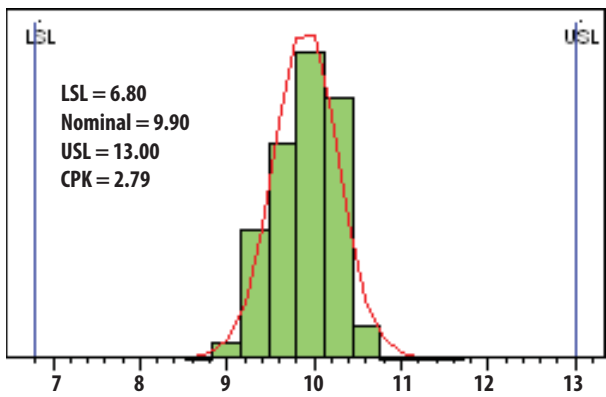

Figure 3. Idd @ 5.5 GHz, Vd 3V; Vshutdown 3 V

### Notes:

1. Distribution data sample size are 6000 samples taken from 3 different wafers and 3 different lots. Future wafers allocated to this product may have nominal values anywhere between the upper and lower limits.

## 5.5 GHz Tuned Demo Board Layout

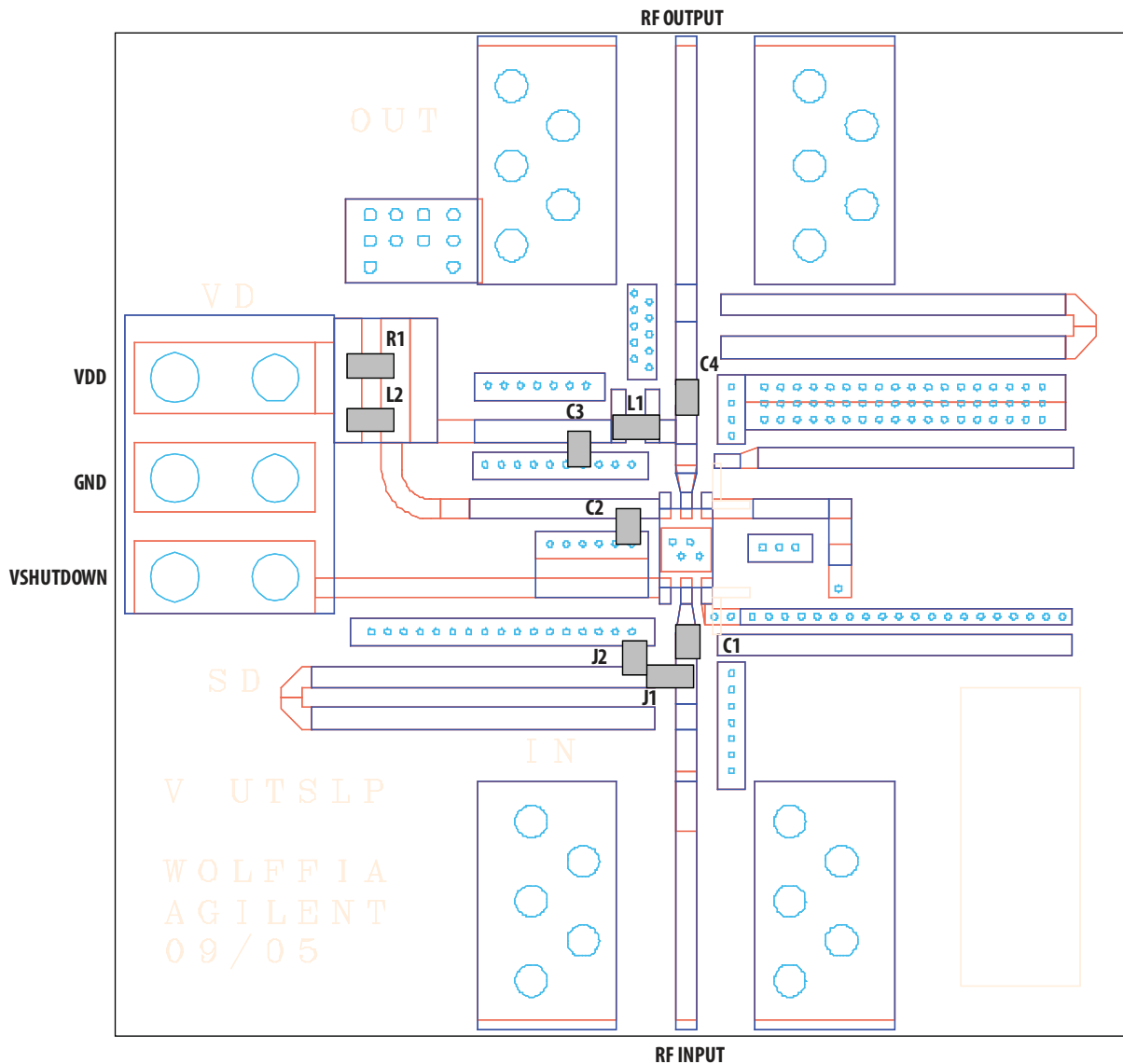

Figure 4 . Demo Board Layout For 5.5 GHz operation [1,2]

Notes:

1. Performance in a specified frequency band can be optimized by changing component values in the demo board above to suit the application at that frequency.
2. Jumpers [J1,J2] indicated in the demo board are not needed in actual application board; this is because generic demo board were used for development.

### Demo Board Components

Components	Value	P/N	Components	Value	P/N
J1,J2	0 ohm	RK73Z1E000 (KOA)	L1	1 nH	LL1005-FHL1N0S (TOKO)
C1	2.4 pF	Rohm	L2	10 nH	LL1005-FHL10NJ (TOKO)
C2	1.6 pF	Rohm	R1	51 ohm	RK73B1ETTP (KOA)
C3	3 pF	Kyocera	C4	2pF	Rohm

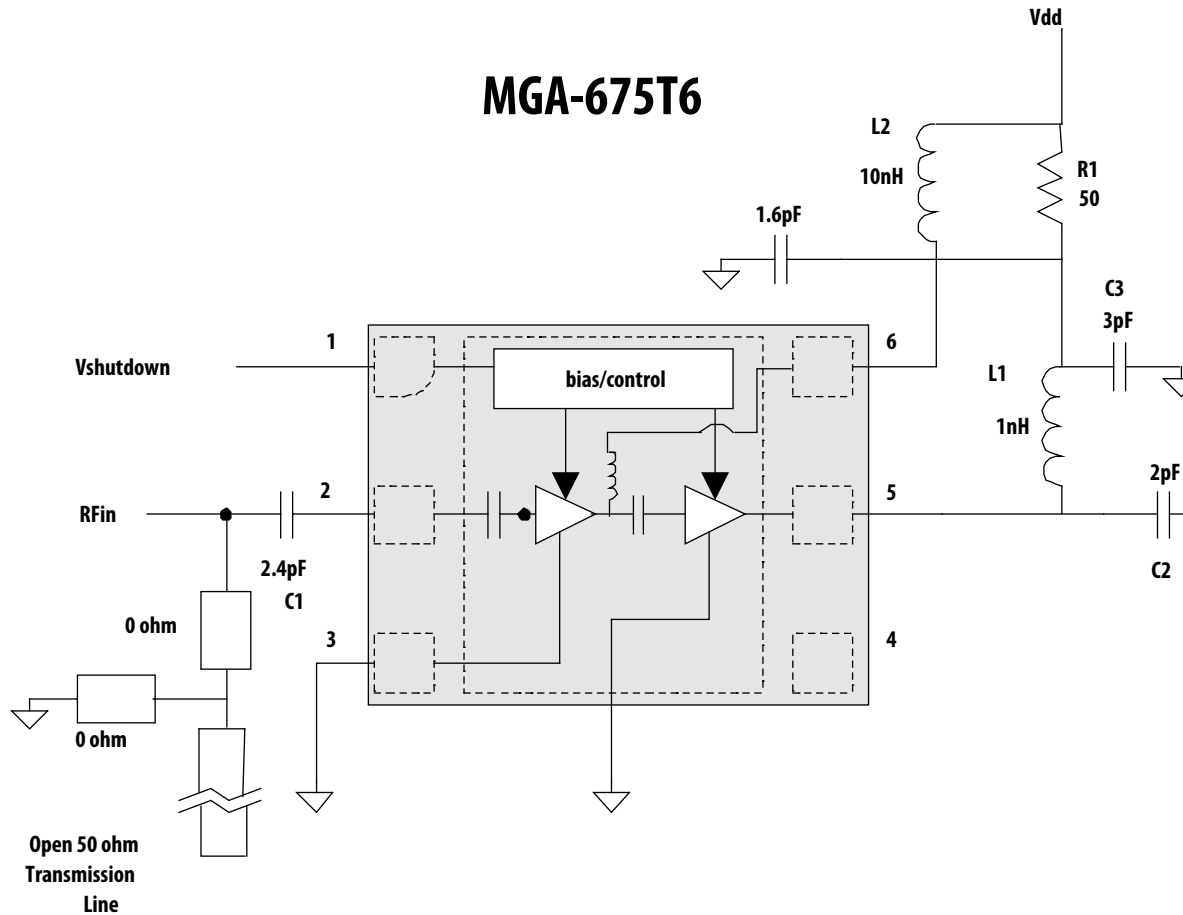

Figure 5. Demo Board Schematic Diagram

Notes:

1. The 0 Ohm resistors at the input are inductive, they are used as recommended matching elements in place of inductors. An alternative is to use shunt transmission lines, but this method is much more repeatable.
2. L2 and R1 are used to isolate the LNA demoboard from external power supply variations. They may not be needed in actual applications.
3. C1, C2, C3 and L1 are input and output matching components.

## MGA-675T6 Typical Performance

$T_A = +25^\circ\text{C}$ ,  $V_{dd} = 3\text{V}$ ,  $I_{ds} = 10\text{mA}$ , RF measurement at 5.5 GHz, Input Signal = CW unless stated otherwise.

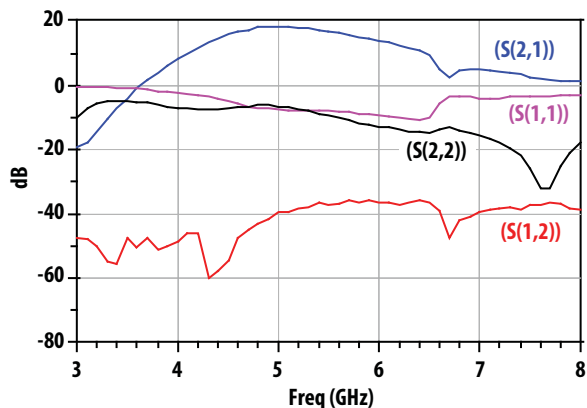

Figure 6. S21, S11, S22, S12 vs Frequency

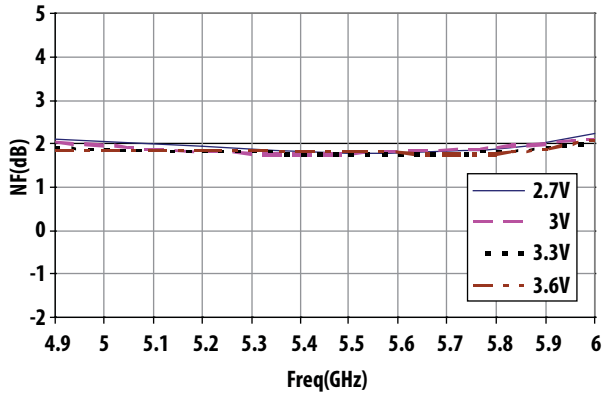

Figure 7. Noise Figure vs Frequency vs Vdd

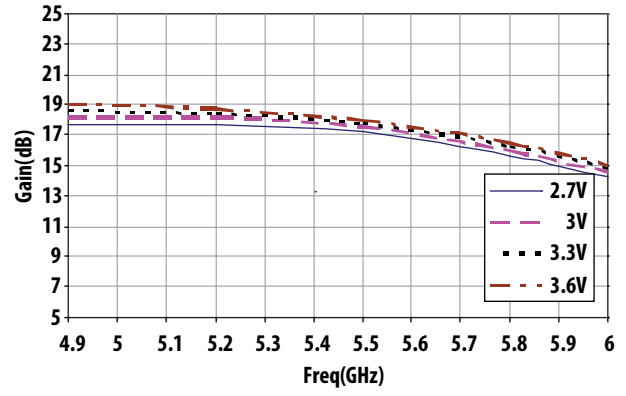

Figure 8. Gain vs Frequency vs Vdd

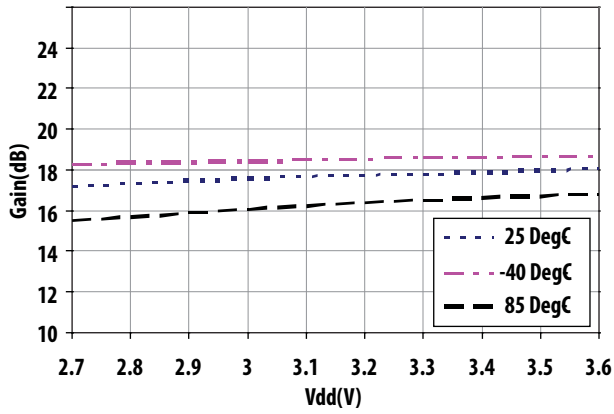

Figure 9. Gain vs Vdd vs Temperature

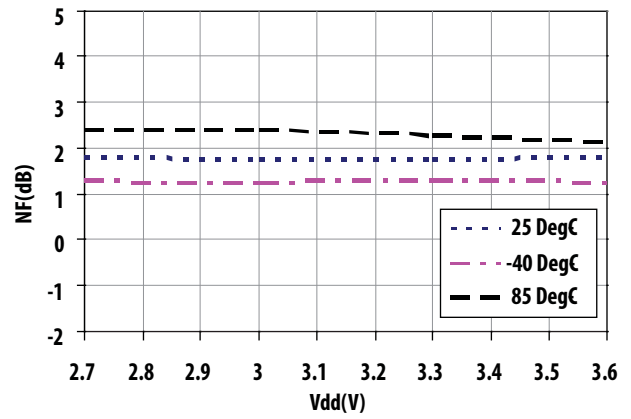

Figure 10. Noise Figure vs Vdd vs Temperature

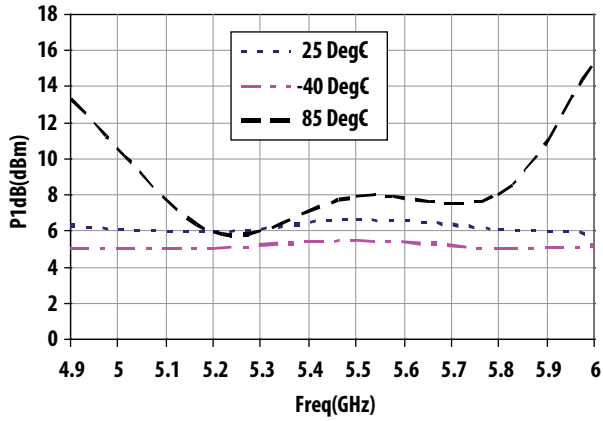

Figure 11. OP1dB vs Frequency vs Temperature

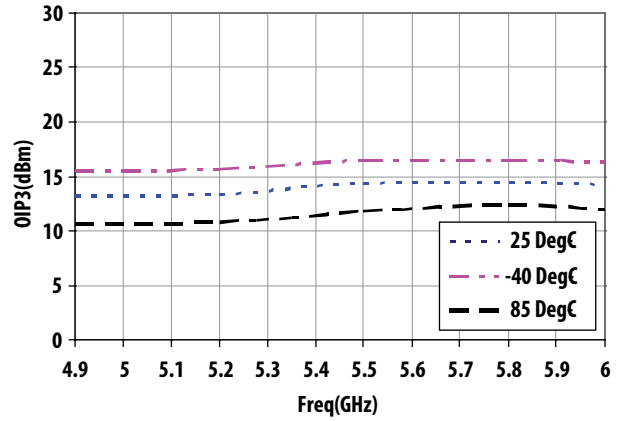

Figure 12 . OIP3 vs Frequency vs Temperature

### Test Circuit For S and Noise parameter measurement [1]

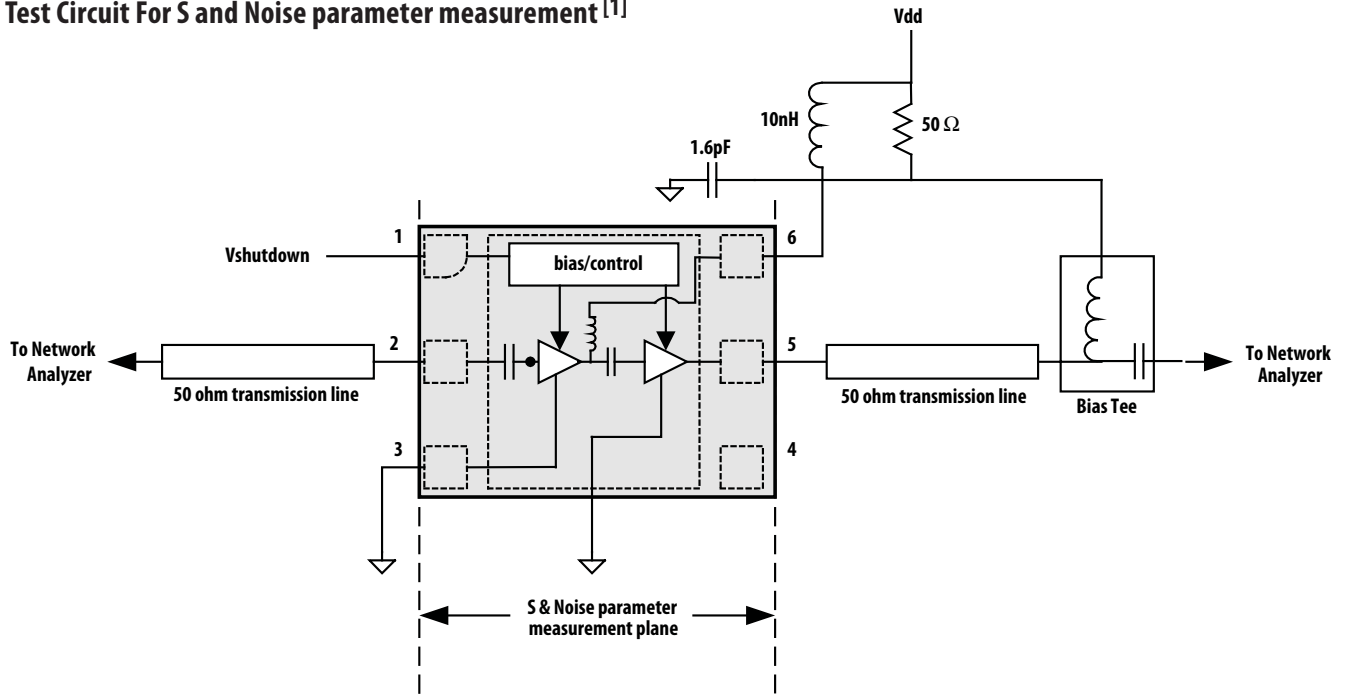

Figure 13. S-parameter measurement schematic

Note 1: The measurement is calibrated up to the input (RFin) and output (RFout) pin of the package.

**MGA-675T6 typical scattering parameters at 25C, Vdd = 2.7V ; Id = 10mA**

Freq. (GHz)	S11		S21		S12		S22			
	Mag	Ang	(dB)	Mag	Ang	(dB)	Mag	Ang	Mag	Ang
0.1	0.99	-2.59	3.69	1.53	30.71	-67.96	0.0004	-177.55	0.13	106.81
0.2	0.97	-3.79	7.27	2.31	-33.14	-60	0.001	27.88	0.29	71.85
0.3	0.98	-5.33	2.35	1.31	-43.02	-61.94	0.0008	167.54	0.38	55.09
0.4	0.97	-6.64	-1.01	0.89	-43.52	-60	0.001	63.37	0.45	44.25
0.5	0.97	-8.55	-2.97	0.71	-40.29	-64.44	0.0006	151.25	0.49	35.45
0.6	0.97	-10.2	-7.96	0.4	-28.99	-64.44	0.0006	146.8	0.52	29.67
0.7	0.96	-12.53	-0.09	0.99	-18.06	-67.96	0.0004	17.47	0.54	24.42
0.8	0.97	-13.26	-7.96	0.4	-39.81	-70.46	0.0003	111.69	0.55	21.06
0.9	0.96	-15.37	-12.04	0.25	-5.49	-59.17	0.0011	126.32	0.57	17.33
1	0.97	-17.3	-8.64	0.37	24.51	-61.94	0.0008	100.62	0.57	14.31
1.1	0.96	-19.09	-9.12	0.35	-6.95	-61.94	0.0008	119.41	0.58	11.99
1.2	0.97	-20.67	-13.15	0.22	39.62	-60	0.001	111.76	0.58	9.5
1.3	0.95	-23.28	-7.74	0.41	39.77	-58.42	0.0012	163.47	0.59	7.02
1.4	0.94	-24.92	-9.63	0.33	8.82	-61.94	0.0008	131.07	0.6	5.15
1.5	0.94	-25.77	-18.42	0.12	44.26	-60	0.001	130.93	0.6	3.62
1.6	0.94	-27.82	-14.89	0.18	93.1	-58.42	0.0012	137.92	0.6	1.53
1.7	0.94	-29.65	-11.37	0.27	104.96	-57.72	0.0013	124.53	0.61	0.35
1.8	0.94	-31.87	-8.87	0.36	109.69	-60	0.001	149.79	0.61	-2.02
1.9	0.94	-34.31	-7.54	0.42	109.02	-58.42	0.0012	144.32	0.62	-3.5
2	0.92	-36.01	-8.18	0.39	107.97	-59.17	0.0011	123.65	0.62	-6.32
2.1	0.92	-37.2	-9.9	0.32	129.9	-57.72	0.0013	156.26	0.63	-8.21
2.2	0.94	-38.86	-7.96	0.4	157.86	-59.17	0.0011	138.53	0.63	-10.52
2.3	0.95	-41.52	-2.5	0.75	167.32	-57.72	0.0013	105.16	0.62	-12.73
2.4	0.94	-45.18	1.21	1.15	158.87	-60.92	0.0009	101.67	0.62	-15.48
2.5	0.91	-48	3.81	1.55	147.62	-66.02	0.0005	36.3	0.61	-17.99
2.6	0.86	-48.6	4.08	1.6	137.6	-60.92	0.0009	-24.46	0.61	-21.26
2.7	0.86	-48.44	4.03	1.59	141.78	-63.1	0.0007	6.74	0.59	-26.43
2.8	0.86	-52.93	9.6	3.02	148.27	-52.77	0.0023	10.01	0.53	-28.03
2.9	0.82	-51.17	7.23	2.3	110.62	-51.7	0.0026	-70.77	0.55	-33.46
3	0.83	-51.87	5.62	1.91	109.58	-50.17	0.0031	-65.16	0.51	-41.28
3.1	0.83	-52.62	4.81	1.74	109.89	-52.04	0.0025	-66.06	0.44	-49.62
3.2	0.83	-53.67	4.14	1.61	109.81	-50.46	0.003	-64.77	0.36	-57.82
3.3	0.83	-54.86	3.86	1.56	120.94	-52.77	0.0023	-58.95	0.25	-68.53
3.4	0.83	-56.61	5.01	1.78	126.62	-49.9	0.0032	-64.57	0.14	-72.73
3.5	0.82	-57.87	4.14	1.61	125.04	-50.46	0.003	-72.22	0.06	-78.31
3.6	0.83	-58.86	4.45	1.67	143.01	-51.7	0.0026	-64.33	0.05	93.79
3.7	0.83	-60.33	6.61	2.14	148.43	-52.4	0.0024	-71.24	0.15	79.52
3.8	0.83	-62.18	8.16	2.56	148.25	-56.48	0.0015	-51.97	0.22	70.75
3.9	0.83	-64.06	9.31	2.92	146.97	-54.89	0.0018	-39.72	0.28	63.76
4	0.83	-66.07	10.21	3.24	144.72	-53.56	0.0021	-44.21	0.33	58.56
4.1	0.83	-68.08	11.36	3.7	144.46	-53.56	0.0021	-18.91	0.36	53.26
4.2	0.83	-70.26	12.17	4.06	142.99	-50.46	0.003	-5.36	0.39	48.44
4.3	0.83	-73.21	13.2	4.57	140.51	-50.75	0.0029	23.05	0.41	43.34
4.4	0.83	-76.36	14.1	5.07	138.4	-46.38	0.0048	14.6	0.43	38.09
4.5	0.83	-80.17	15.04	5.65	132.9	-44.29	0.0061	22.37	0.43	32.27
4.6	0.82	-84.42	15.72	6.11	128.41	-42.85	0.0072	20.69	0.43	25.71
4.7	0.8	-89.3	16.1	6.38	122.35	-40.45	0.0095	22.19	0.43	18.82
4.8	0.79	-94.44	16.81	6.93	116.19	-38.79	0.0115	12.23	0.41	10.97
4.9	0.76	-99.04	17.12	7.18	110.18	-37.99	0.0126	9.31	0.39	2.39
5	0.73	-104.23	17.33	7.35	103.26	-37.2	0.0138	7.09	0.36	-6.66
5.1	0.69	-109.26	17.27	7.3	97	-36.25	0.0154	-0.29	0.32	-16.38
5.2	0.65	-113.85	17.12	7.18	90.4	-35.81	0.0162	-6.73	0.28	-25.81
5.3	0.61	-118.16	16.81	6.93	84.93	-35.44	0.0169	-8.69	0.24	-34.44
5.4	0.57	-121.95	16.38	6.59	79.15	-35.09	0.0176	-9.87	0.21	-43.78
5.5	0.54	-125.86	15.93	6.26	73.94	-35.09	0.0176	-13.04	0.18	-52.76
5.6	0.52	-129.8	15.37	5.87	70.49	-34.85	0.0181	-15.94	0.16	-61.58
5.7	0.5	-132.62	14.7	5.43	67.4	-35.04	0.0177	-17.02	0.14	-70.58
5.8	0.48	-135.91	14.08	5.06	64.04	-34.89	0.018	-18.14	0.13	-77.46
5.9	0.47	-139.49	13.48	4.72	62.99	-35.34	0.0171	-18.65	0.12	-83.07
6	0.46	-142.88	12.91	4.42	60.97	-35.65	0.0165	-19.02	0.11	-88.39



**MGA-675T6 typical scattering parameters at 25C, Vdd = 3V ; Id = 10mA**

Freq. (GHz)	S11		S21		S12		S22			
	Mag	Ang	(dB)	Mag	Ang	(dB)	Mag	Ang	Mag	Ang
0.1	0.98	-2.59	4.61	1.7	32.83	-57.72	0.0013	-69.46	0.15	121.22
0.2	0.97	-3.76	8.23	2.58	-31.93	-64.44	0.0006	49.69	0.29	79.38
0.3	0.97	-5.34	3.46	1.49	-41.84	-66.02	0.0005	-6.57	0.38	60.53
0.4	0.98	-6.72	0.17	1.02	-42.59	-64.44	0.0006	81.29	0.44	48.29
0.5	0.98	-8.71	-1.72	0.82	-39.8	-70.46	0.0003	-0.79	0.48	39.02
0.6	0.97	-10.33	-6.74	0.46	-28.34	-63.1	0.0007	148.94	0.51	32.6
0.7	0.96	-12.45	1.06	1.13	-17.8	-63.1	0.0007	100.29	0.53	27.07
0.8	0.97	-13.61	-6.74	0.46	-39.49	-73.98	0.0002	108.89	0.55	23.41
0.9	0.96	-15.73	-10.75	0.29	-5.22	-61.94	0.0008	99.59	0.56	19.44
1	0.96	-17.68	-7.33	0.43	23.81	-64.44	0.0006	176.73	0.57	16.28
1.1	0.96	-19.34	-7.74	0.41	-7.3	-67.96	0.0004	114.33	0.57	13.76
1.2	0.96	-21.26	-11.7	0.26	38.87	-64.44	0.0006	130.66	0.58	11.27
1.3	0.95	-23.87	-6.38	0.48	38.85	-60.92	0.0009	140.3	0.59	8.72
1.4	0.94	-25.36	-8.4	0.38	8.15	-58.42	0.0012	155.61	0.59	6.56
1.5	0.94	-26.54	-17.08	0.14	41.7	-60	0.001	123.69	0.6	5.03
1.6	0.94	-28.43	-13.56	0.21	91.48	-63.1	0.0007	108.74	0.6	2.8
1.7	0.94	-30.46	-10.17	0.31	102.93	-70.46	0.0003	137.38	0.6	1.32
1.8	0.94	-32.57	-7.74	0.41	108.09	-60.92	0.0009	147.12	0.61	-0.9
1.9	0.93	-35.04	-6.38	0.48	107.23	-67.96	0.0004	-179.6	0.61	-2.48
2	0.91	-36.7	-6.94	0.45	105.79	-67.96	0.0004	170.99	0.61	-5.14
2.1	0.91	-37.85	-8.87	0.36	127.65	-59.17	0.0011	177.81	0.62	-7.27
2.2	0.93	-39.65	-6.74	0.46	156.13	-57.08	0.0014	145.6	0.62	-9.87
2.3	0.94	-42.52	-1.31	0.86	165.39	-63.1	0.0007	105.37	0.61	-12.03
2.4	0.93	-46.22	2.41	1.32	156.28	-67.96	0.0004	70.45	0.61	-14.6
2.5	0.9	-48.77	4.91	1.76	145.22	-64.44	0.0006	2.3	0.59	-17.2
2.6	0.86	-49.41	5.25	1.83	135.16	-63.1	0.0007	3.87	0.59	-20.85
2.7	0.85	-49.59	5.11	1.8	139.21	-63.1	0.0007	-9.1	0.57	-26.09
2.8	0.85	-53.75	10.66	3.41	144.59	-54.42	0.0019	3.6	0.5	-26.81
2.9	0.81	-52.13	8.23	2.58	107.52	-52.77	0.0023	-71.16	0.53	-32.63
3	0.82	-52.76	6.57	2.13	106.6	-52.4	0.0024	-67.84	0.48	-40.48
3.1	0.81	-53.59	5.67	1.92	106.84	-51.37	0.0027	-86.26	0.41	-48.5
3.2	0.81	-54.87	4.96	1.77	106.93	-51.7	0.0026	-70.69	0.32	-56.18
3.3	0.82	-55.89	4.66	1.71	118.37	-51.06	0.0028	-70.45	0.22	-65.52
3.4	0.82	-57.7	5.71	1.93	124.35	-51.7	0.0026	-77.41	0.11	-64.58
3.5	0.81	-58.69	4.91	1.76	122.96	-50.17	0.0031	-84.78	0.03	-47.85
3.6	0.81	-59.94	5.25	1.83	140.95	-52.04	0.0025	-90.85	0.08	83.09
3.7	0.81	-61.58	7.35	2.33	146.62	-52.04	0.0025	-88.66	0.17	76.97
3.8	0.82	-63.37	8.94	2.8	146.43	-52.77	0.0023	-80.13	0.24	70.01
3.9	0.81	-64.83	10.05	3.18	145.42	-57.08	0.0014	-48.45	0.3	64.18
4	0.82	-67.27	11	3.55	142.87	-55.92	0.0016	-63.4	0.35	59.07
4.1	0.81	-69.26	12.13	4.04	142.8	-56.48	0.0015	-34.76	0.38	54.18
4.2	0.81	-71.59	12.95	4.44	141.1	-54.42	0.0019	-21.47	0.41	49.56
4.3	0.82	-74.35	14	5.01	138.88	-53.15	0.0022	-0.19	0.43	44.74
4.4	0.82	-77.71	14.9	5.56	136.49	-49.12	0.0035	18.8	0.44	39.96
4.5	0.81	-81.35	15.82	6.18	130.99	-46.02	0.005	21.99	0.45	34.32
4.6	0.8	-86.25	16.51	6.69	126.3	-44.01	0.0063	19.55	0.45	28.09
4.7	0.79	-90.48	16.89	6.99	120.18	-42.5	0.0075	27.49	0.44	21.66
4.8	0.77	-96.17	17.56	7.55	113.85	-40	0.01	16.38	0.43	13.96
4.9	0.74	-100.89	17.85	7.81	107.79	-39.09	0.0111	11.08	0.4	5.99
5	0.7	-106.34	18.02	7.96	100.78	-37.86	0.0128	6.64	0.36	-2.82
5.1	0.67	-110.9	17.95	7.9	94.75	-37.27	0.0137	1.32	0.32	-11.37
5.2	0.63	-115.89	17.76	7.73	87.84	-37.08	0.014	-5.27	0.28	-20.37
5.3	0.58	-120.09	17.41	7.42	82.47	-36.42	0.0151	-5.9	0.24	-27.88
5.4	0.55	-124.02	16.96	7.05	77.09	-36.19	0.0155	-9.69	0.21	-36.56
5.5	0.53	-128.18	16.5	6.68	71.71	-35.7	0.0164	-10.94	0.18	-44.5
5.6	0.5	-131.65	15.95	6.27	68.62	-35.7	0.0164	-14.41	0.15	-53.18
5.7	0.48	-134.91	15.27	5.8	65.41	-36.14	0.0156	-16.94	0.13	-61.03
5.8	0.46	-138.4	14.62	5.38	62.06	-35.97	0.0159	-17.8	0.11	-67.41
5.9	0.46	-142.15	14.03	5.03	60.88	-36.31	0.0153	-16.37	0.11	-73.23
6	0.45	-145.59	13.4	4.68	59.06	-36.36	0.0152	-14.34	0.1	-78.59

**MGA-675T6 typical scattering parameters at 25C, Vdd = 3.3V ; Id = 10mA**

Freq. (GHz)	S11		S21		S12		S22			
	Mag	Ang	(dB)	Mag	Ang	(dB)	Mag	Ang	Mag	Ang
0.1	0.99	-2.75	5.39	1.86	32.62	-61.94	0.0008	154.78	0.16	128.17
0.2	0.97	-3.91	9.16	2.87	-30.82	-64.44	0.0006	114.74	0.29	84.42
0.3	0.97	-5.54	4.4	1.66	-41.07	-70.46	0.0003	29.9	0.38	64.45
0.4	0.97	-6.99	1.21	1.15	-42.19	-73.98	0.0002	96.9	0.44	51.63
0.5	0.97	-8.89	-0.82	0.91	-38.51	-63.1	0.0007	72.31	0.48	41.81
0.6	0.97	-10.64	-5.51	0.53	-27.99	-73.98	0.0002	-39.74	0.51	35.03
0.7	0.96	-12.82	2.14	1.28	-17.94	-66.02	0.0005	94.97	0.53	29.15
0.8	0.97	-13.94	-5.85	0.51	-39.17	-60.92	0.0009	139.33	0.54	25.29
0.9	0.96	-15.92	-9.63	0.33	-5.26	-70.46	0.0003	89.65	0.56	21.27
1	0.96	-17.92	-6.2	0.49	23.75	-61.94	0.0008	131.57	0.56	17.98
1.1	0.95	-19.7	-6.56	0.47	-6.99	-64.44	0.0006	122.86	0.57	15.36
1.2	0.96	-21.54	-10.75	0.29	38.13	-64.44	0.0006	179.8	0.57	12.6
1.3	0.95	-24.45	-5.35	0.54	37.6	-60	0.001	110.06	0.58	10.11
1.4	0.93	-25.89	-7.33	0.43	7.43	-59.17	0.0011	134.35	0.59	7.85
1.5	0.93	-27.13	-15.92	0.16	39.32	-59.17	0.0011	139.06	0.59	6.05
1.6	0.94	-28.86	-12.4	0.24	89.6	-57.72	0.0013	144.61	0.59	3.91
1.7	0.94	-31.06	-8.87	0.36	101.54	-61.94	0.0008	145.19	0.6	2.46
1.8	0.93	-33.25	-6.74	0.46	106.38	-64.44	0.0006	145.54	0.6	0.12
1.9	0.93	-35.76	-5.35	0.54	105.18	-59.17	0.0011	160.8	0.61	-1.54
2	0.91	-37.42	-6.02	0.5	103.87	-59.17	0.0011	160.25	0.61	-4.3
2.1	0.9	-38.81	-7.96	0.4	125.24	-54.42	0.0019	162.3	0.61	-6.41
2.2	0.92	-40.3	-5.68	0.52	154.67	-59.17	0.0011	126.89	0.61	-8.92
2.3	0.93	-43.23	-0.35	0.96	163.27	-60	0.001	159.64	0.6	-11.21
2.4	0.92	-47.01	3.35	1.47	154.25	-64.44	0.0006	161.41	0.59	-13.91
2.5	0.89	-49.71	5.85	1.96	142.91	-67.96	0.0004	50.77	0.58	-16.28
2.6	0.85	-50.38	6.15	2.03	133.07	-58.42	0.0012	-32.8	0.57	-20.09
2.7	0.84	-50.33	5.98	1.99	136.89	-60.92	0.0009	-55.06	0.55	-24.98
2.8	0.84	-54.84	11.5	3.76	141.33	-53.56	0.0021	-22.51	0.49	-25.36
2.9	0.8	-53.02	9.07	2.84	104.86	-51.06	0.0028	-66.02	0.51	-31.37
3	0.81	-53.56	7.31	2.32	103.75	-51.7	0.0026	-68.81	0.45	-39.29
3.1	0.8	-54.6	6.44	2.1	103.97	-52.04	0.0025	-80.45	0.38	-46.7
3.2	0.81	-55.72	5.71	1.93	104.61	-50.75	0.0029	-69.64	0.29	-53.36
3.3	0.81	-57.09	5.34	1.85	115.96	-51.7	0.0026	-81.78	0.19	-60.37
3.4	0.8	-58.74	6.36	2.08	121.9	-52.4	0.0024	-82.48	0.08	-50.34
3.5	0.8	-59.77	5.53	1.89	121.06	-50.46	0.003	-81.35	0.03	8.74
3.6	0.8	-60.99	5.85	1.96	138.93	-50.75	0.0029	-96.45	0.1	76.5
3.7	0.8	-62.54	7.92	2.49	144.56	-52.4	0.0024	-91.3	0.19	74.04
3.8	0.8	-64.1	9.57	3.01	144.67	-55.39	0.0017	-93.5	0.26	68.91
3.9	0.8	-66.11	10.68	3.42	143.65	-54.89	0.0018	-88.3	0.32	63.56
4	0.8	-68.12	11.62	3.81	141.42	-60	0.001	-82.14	0.36	59.23
4.1	0.8	-70.18	12.77	4.35	141.04	-58.42	0.0012	-35.3	0.4	54.59
4.2	0.8	-72.53	13.57	4.77	139.54	-57.08	0.0014	-25.4	0.42	50.33
4.3	0.8	-75.74	14.66	5.41	137.24	-55.92	0.0016	15.87	0.44	45.87
4.4	0.8	-78.97	15.53	5.98	134.81	-51.7	0.0026	24.52	0.46	41.03
4.5	0.8	-82.69	16.47	6.66	129.21	-49.37	0.0034	22.58	0.47	35.73
4.6	0.79	-87.35	17.13	7.19	124.5	-45.19	0.0055	26.13	0.46	29.86
4.7	0.77	-92.53	17.5	7.5	118.07	-43.35	0.0068	27.16	0.46	23.54
4.8	0.75	-97.47	18.14	8.07	111.75	-41.83	0.0081	11.85	0.44	16.26
4.9	0.72	-102.29	18.42	8.34	105.9	-39.74	0.0103	13.29	0.41	8.53
5	0.68	-107.9	18.58	8.49	98.7	-38.86	0.0114	6.79	0.37	0.66
5.1	0.65	-112.67	18.49	8.4	92.7	-37.86	0.0128	2.18	0.33	-7.41
5.2	0.61	-117.77	18.29	8.21	86.02	-37.39	0.0135	-4.09	0.29	-15.43
5.3	0.57	-122.2	17.92	7.87	80.47	-37.33	0.0136	-5.77	0.25	-22.47
5.4	0.54	-126.08	17.49	7.49	75.41	-36.95	0.0142	-7.44	0.21	-29.74
5.5	0.51	-130.3	17.03	7.1	70.07	-37.14	0.0139	-8.12	0.18	-36.43
5.6	0.48	-134.36	16.4	6.61	66.71	-36.48	0.015	-14.54	0.15	-43.57
5.7	0.46	-137.46	15.69	6.09	63.81	-36.89	0.0143	-13.84	0.12	-51.05
5.8	0.45	-140.98	15.1	5.69	60.67	-36.77	0.0145	-14.83	0.11	-56.47
5.9	0.44	-144.85	14.45	5.28	59.42	-37.2	0.0138	-12.85	0.1	-61.36
6	0.43	-148.33	13.87	4.94	57.55	-37.08	0.014	-15.1	0.09	-66.02

**MGA-675T6 typical scattering parameters at 25C, Vdd = 3.6V ; Id = 10mA**

Freq. (GHz)	S11		S21		S12		S22			
	Mag	Ang	(dB)	Mag	Ang	(dB)	Mag	Ang	Mag	Ang
0.1	0.98	-2.73	6.11	2.02	34.32	-57.72	0.0013	-49.5	0.17	131.85
0.2	0.97	-4.04	9.8	3.09	-29.59	-60.92	0.0009	133.51	0.29	88.39
0.3	0.97	-5.65	5.15	1.81	-40.52	-63.1	0.0007	-58.56	0.38	67.44
0.4	0.97	-7.18	1.94	1.25	-41.68	-66.02	0.0005	40.59	0.44	53.88
0.5	0.97	-9.17	-0.09	0.99	-38.14	-59.17	0.0011	44.89	0.48	43.72
0.6	0.97	-11.14	-4.73	0.58	-27.74	-64.44	0.0006	108.49	0.51	36.72
0.7	0.96	-13.04	2.98	1.41	-18.39	-70.46	0.0003	136.44	0.53	30.69
0.8	0.97	-14.44	-4.88	0.57	-38.99	-67.96	0.0004	138.77	0.54	26.75
0.9	0.96	-16.49	-8.87	0.36	-5.06	-60.92	0.0009	147.61	0.56	22.56
1	0.96	-18.51	-5.35	0.54	23.03	-61.94	0.0008	110.04	0.56	18.96
1.1	0.95	-20.15	-5.85	0.51	-6.31	-63.1	0.0007	159.42	0.57	16.46
1.2	0.96	-21.98	-9.9	0.32	37.59	-63.1	0.0007	111.08	0.57	13.58
1.3	0.94	-24.8	-4.44	0.6	36.76	-60	0.001	130.43	0.58	10.94
1.4	0.93	-26.59	-6.56	0.47	6.95	-60	0.001	138.39	0.59	8.77
1.5	0.93	-27.78	-15.39	0.17	37.41	-60	0.001	130.16	0.59	7.1
1.6	0.93	-29.7	-11.37	0.27	88.53	-59.17	0.0011	112.69	0.59	4.83
1.7	0.93	-31.59	-8.18	0.39	99.96	-60.92	0.0009	141.18	0.6	3.21
1.8	0.93	-34.13	-5.85	0.51	104.93	-60.92	0.0009	163.35	0.6	0.9
1.9	0.92	-36.49	-4.58	0.59	103.53	-64.44	0.0006	144.84	0.61	-0.82
2	0.9	-38.21	-5.19	0.55	102.51	-59.17	0.0011	153.04	0.61	-3.54
2.1	0.9	-39.46	-7.13	0.44	123.42	-58.42	0.0012	135.81	0.61	-5.73
2.2	0.91	-41.27	-4.88	0.57	152.98	-60	0.001	152.49	0.6	-8.26
2.3	0.93	-44.21	0.34	1.04	161.29	-58.42	0.0012	163.48	0.59	-10.46
2.4	0.91	-47.84	4.08	1.6	152.75	-60.92	0.0009	-175.57	0.59	-12.95
2.5	0.88	-50.51	6.49	2.11	141.06	-73.98	0.0002	108.04	0.57	-15.64
2.6	0.84	-51.29	6.85	2.2	130.99	-66.02	0.0005	-27.29	0.56	-19.14
2.7	0.84	-51.6	6.69	2.16	134.74	-67.96	0.0004	-56.92	0.54	-24.18
2.8	0.83	-55.72	12.15	4.05	138.7	-55.39	0.0017	-26.93	0.47	-23.73
2.9	0.8	-54.26	9.63	3.03	102.64	-53.15	0.0022	-87.43	0.49	-30.11
3	0.8	-54.77	7.89	2.48	101.36	-51.37	0.0027	-88.19	0.43	-37.32
3.1	0.79	-55.87	6.97	2.23	101.3	-51.37	0.0027	-91.6	0.35	-44.03
3.2	0.79	-56.93	6.24	2.05	102.28	-50.17	0.0031	-88.77	0.26	-48.94
3.3	0.79	-58.26	5.8	1.95	113.9	-51.06	0.0028	-77.82	0.16	-52.42
3.4	0.79	-60.03	6.81	2.19	119.81	-50.46	0.003	-82.32	0.08	-28.67
3.5	0.78	-60.93	5.93	1.98	119.47	-49.63	0.0033	-91.23	0.06	30.86
3.6	0.78	-61.98	6.28	2.06	137.24	-49.63	0.0033	-100.44	0.13	70.3
3.7	0.78	-63.46	8.33	2.61	143.03	-53.15	0.0022	-109.08	0.21	70.42
3.8	0.78	-65.28	9.99	3.16	143.15	-53.56	0.0021	-102.03	0.28	66.53
3.9	0.78	-67.04	11.13	3.6	142.27	-52.77	0.0023	-101.87	0.34	62.19
4	0.78	-69.2	12.06	4.01	139.96	-56.48	0.0015	-93.08	0.38	58.38
4.1	0.78	-71.4	13.18	4.56	139.8	-58.42	0.0012	-79.41	0.41	54.29
4.2	0.78	-73.72	14	5.01	138.08	-60	0.001	-34.42	0.44	50.24
4.3	0.78	-76.54	15.09	5.68	135.87	-56.48	0.0015	14.51	0.46	46.03
4.4	0.79	-79.96	15.99	6.3	133.48	-53.98	0.002	8.58	0.47	41.52
4.5	0.77	-83.93	16.9	7	127.65	-51.37	0.0027	25.79	0.48	36.57
4.6	0.77	-88.88	17.55	7.54	122.81	-47.74	0.0041	23.71	0.48	31.02
4.7	0.75	-93.65	17.89	7.84	116.59	-44.29	0.0061	23.67	0.47	25.08
4.8	0.73	-99.06	18.54	8.45	110.07	-42.97	0.0071	17.88	0.45	17.97
4.9	0.7	-103.98	18.8	8.71	104.07	-41.72	0.0082	14.83	0.42	11.06
5	0.67	-109.45	18.95	8.86	96.99	-39.91	0.0101	11.65	0.39	3.61
5.1	0.63	-114.37	18.85	8.76	90.92	-38.71	0.0116	1.6	0.34	-3.72
5.2	0.59	-119.48	18.61	8.52	84.41	-39.02	0.0112	-2.96	0.3	-11.18
5.3	0.55	-123.98	18.29	8.21	79.14	-38.13	0.0124	-5.94	0.26	-17.17
5.4	0.52	-128.13	17.8	7.76	73.75	-37.92	0.0127	-8.81	0.22	-23.44
5.5	0.5	-132.47	17.29	7.32	68.61	-37.72	0.013	-9.09	0.18	-28.95
5.6	0.47	-136.65	16.74	6.87	65.31	-37.33	0.0136	-10.54	0.15	-34.66
5.7	0.45	-139.8	16	6.31	62.42	-37.52	0.0133	-13.35	0.13	-39.63
5.8	0.44	-143.63	15.37	5.87	59.31	-37.39	0.0135	-14.27	0.11	-43.79
5.9	0.43	-147.45	14.76	5.47	58.28	-37.92	0.0127	-13.94	0.1	-48.11
6	0.42	-151.21	14.1	5.07	56.36	-37.65	0.0131	-14.32	0.09	-52.14

**MGA-675T6 typical noise parameters at 25C, Vdd = 2.7V ; Id = 10mA**

Freq.(GHz)	Fmin (dB)	$\Gamma_{opt}$ Mag	$\Gamma_{opt}$ Ang	Rn/50
4.9	1.35126	0.53697	64.949	0.323956
5.2	1.43217	0.40326	68.0102	0.305117
5.5	1.49122	0.40548	77.4672	0.279867
5.8	1.82744	0.33439	94.8074	0.235282
6	2.04859	0.25328	118.4296	0.203811

**MGA-675T6 typical noise parameters at 25C, Vdd = 3V ; Id = 10mA**

Freq.(GHz)	Fmin (dB)	$\Gamma_{opt}$ Mag	$\Gamma_{opt}$ Ang	Rn/50
4.9	1.35601	0.45657	62.0252	0.310886
5.2	1.39364	0.38634	65.7949	0.289666
5.5	1.43979	0.38199	75.883	0.271336
5.8	1.72404	0.32152	93.9554	0.226681
6	1.95541	0.23419	124.0041	0.185029

**MGA-675T6 typical noise parameters at 25C, Vdd = 3.3V ; Id = 10mA**

Freq.(GHz)	Fmin (dB)	$\Gamma_{opt}$ Mag	$\Gamma_{opt}$ Ang	Rn/50
4.9	1.29085	0.45051	62.7022	0.288653
5.2	1.35494	0.36239	64.2459	0.278086
5.5	1.40731	0.35846	76.9741	0.246368
5.8	1.70062	0.29237	92.6917	0.224477
6	1.86238	0.2634	130.4643	0.146939

**MGA-675T6 typical noise parameters at 25C, Vdd = 3.6V ; Id = 10mA**

Freq.(GHz)	Fmin (dB)	$\Gamma_{opt}$ Mag	$\Gamma_{opt}$ Ang	Rn/50
4.9	1.2867	0.41338	60.6672	0.282774
5.2	1.32897	0.35595	65.0199	0.252703
5.5	1.39274	0.34038	76.2336	0.235472
5.8	1.68828	0.28043	93.1996	0.211577
6	1.82103	0.24344	134.5497	0.139986

## Package Dimensions

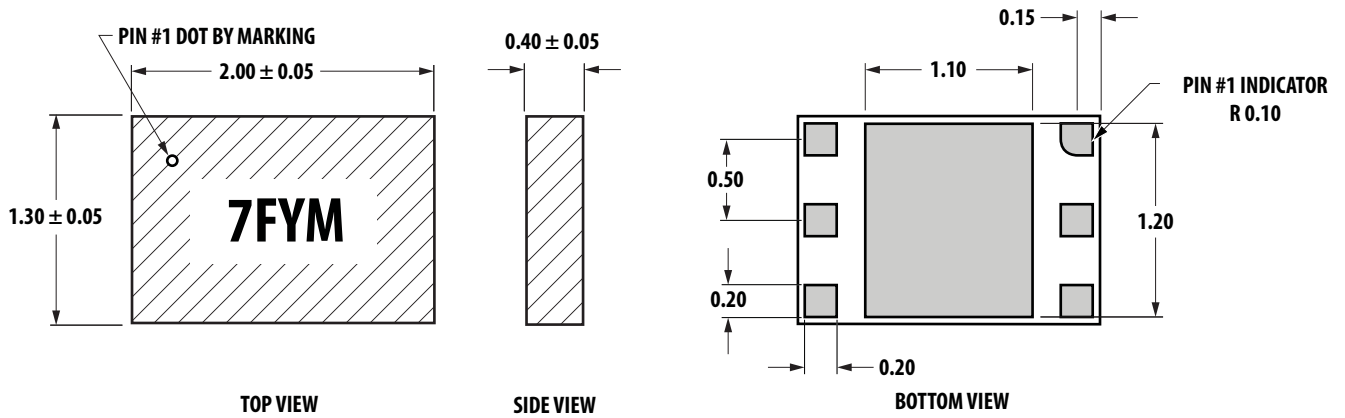

## PCB Land Pattern

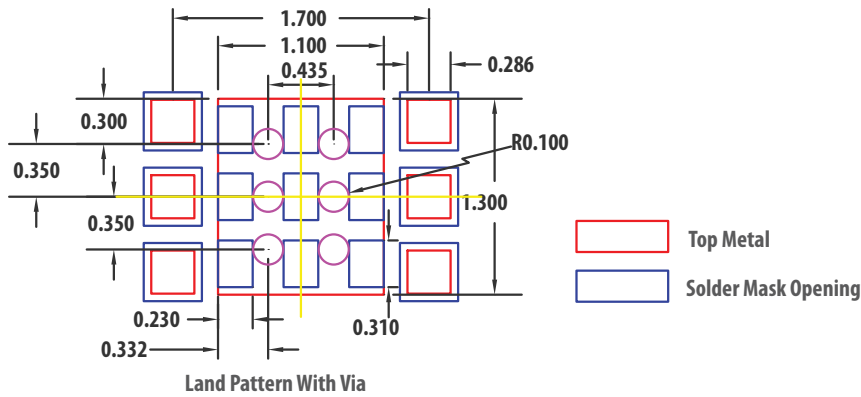

## Stencil Outline Drawing and Combined Land Pattern & Stencil Layout

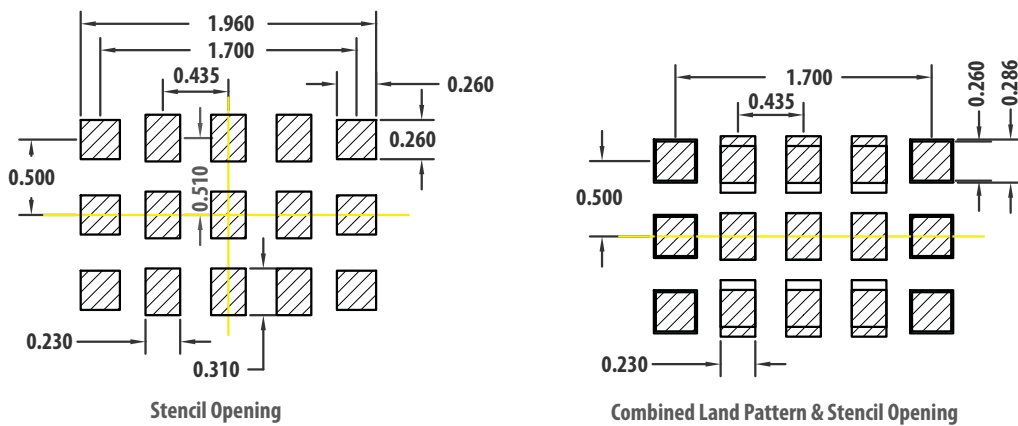

Notes:

1. All dimension are in MM
2. Via hole is optional.
3. Recommend to use standard 4 mils Stencil thickness

## Device Orientation

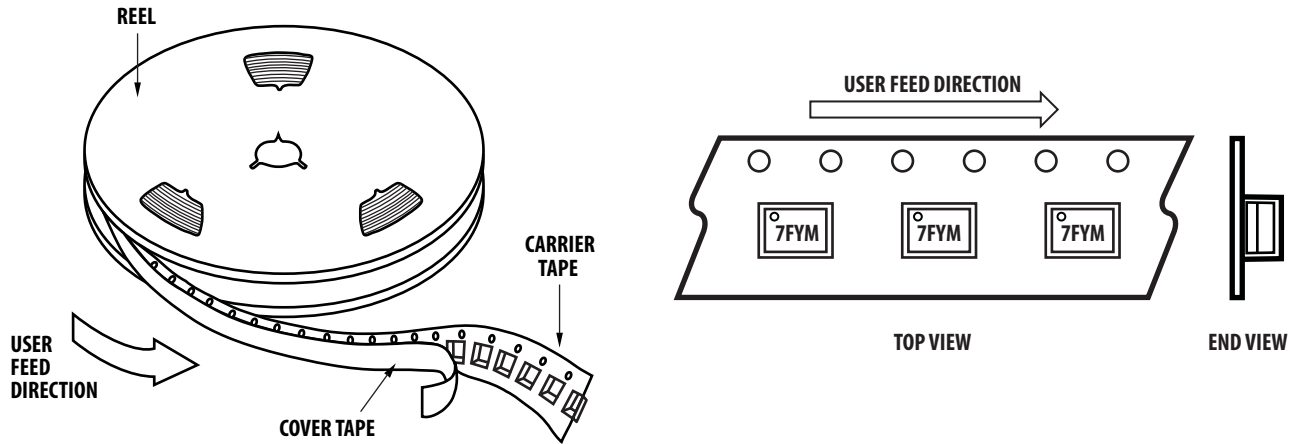

## Tape Dimensions

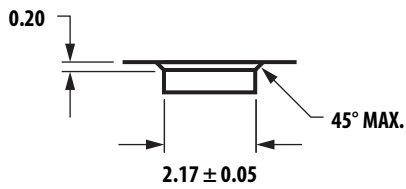
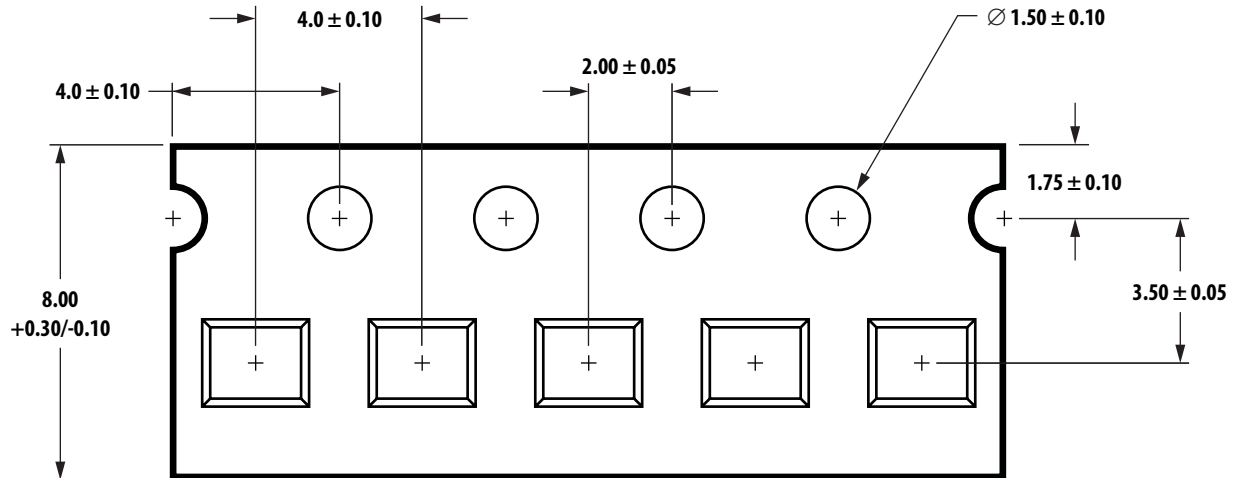

A<sub>0</sub>

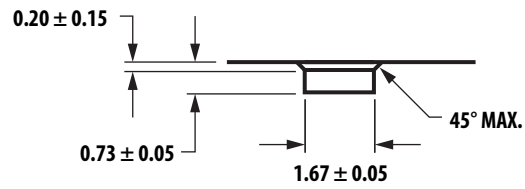

B<sub>0</sub>

B<sub>0</sub>

## Part Number Ordering Information

Part Number	Quantity	Container
MGA-675T6-BLKG	100	antistatic bag
MGA-675T6-TR1G	3000	7" Reel
MGA-675T6-TR2G	10000	13" Reel

# Reel Dimensions - 7 Inch

