

## ADG758/ADG759

### FEATURES

**1.8 V to 5.5 V Single Supply**  
 **$\pm 2.5$  V Dual Supply**  
**3  $\Omega$  ON Resistance**  
**0.75  $\Omega$  ON Resistance Flatness**  
**100 pA Leakage Currents**  
**14 ns Switching Times**  
**Single 8-to-1 Multiplexer ADG758**  
**Differential 4-to-1 Multiplexer ADG759**  
**20-Lead 4 mm  $\times$  4 mm Chip Scale Package**  
**Low Power Consumption**  
**TTL-/CMOS-Compatible Inputs**  
**For Functionally Equivalent Devices in 16-Lead TSSOP Package, See ADG708/ADG709**

### APPLICATIONS

**Data Acquisition Systems**  
**Communication Systems**  
**Relay Replacement**  
**Audio and Video Switching**  
**Battery-Powered Systems**

### GENERAL DESCRIPTION

The ADG758 and ADG759 are low voltage, CMOS analog multiplexers comprising eight single channels and four differential channels, respectively. The ADG758 switches one of eight inputs (S1–S8) to a common output, D, as determined by the 3-bit binary address lines A0, A1, and A2. The ADG759 switches one of four differential inputs to a common differential output as determined by the 2-bit binary address lines A0 and A1. An EN input on both devices is used to enable or disable the device. When disabled, all channels are switched OFF.

Low power consumption and an operating supply range of 1.8 V to 5.5 V make the ADG758 and ADG759 ideal for battery-powered, portable instruments. All channels exhibit break-before-make switching action preventing momentary shorting when switching channels.

These switches are designed on an enhanced submicron process that provides low power dissipation yet gives high switching speed, very low ON resistance and leakage currents. ON resistance is in the region of a few ohms and is closely matched between switches and very flat over the full signal range. These parts can operate equally well as either multiplexers or demultiplexers and have an input signal range that extends to the supplies.

The ADG758 and ADG759 are available in 20-lead chip scale packages.

### REV. B

Information furnished by Analog Devices is believed to be accurate and reliable. However, no responsibility is assumed by Analog Devices for its use, nor for any infringements of patents or other rights of third parties that may result from its use. No license is granted by implication or otherwise under any patent or patent rights of Analog Devices.

### FUNCTIONAL BLOCK DIAGRAMS

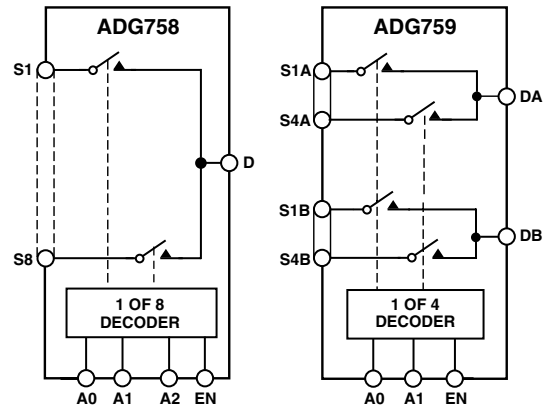

### PRODUCT HIGHLIGHTS

1. Small 20-Lead 4 mm  $\times$  4 mm Chip Scale Packages (CSP).
2. Single/Dual Supply Operation. The ADG758 and ADG759 are fully specified and guaranteed with 3 V and 5 V single-supply and  $\pm 2.5$  V dual-supply rails.
3. Low  $R_{ON}$  (3  $\Omega$  Typical).
4. Low Power Consumption ( $< 0.01 \mu\text{W}$ ).
5. Guaranteed Break-Before-Make Switching Action.

# ADG758/ADG759—SPECIFICATIONS<sup>1</sup> ( $V_{DD} = 5\text{ V} \pm 10\%$ , $V_{SS} = 0\text{ V}$ , $GND = 0\text{ V}$ , unless otherwise noted.)

Parameter	B Version		Unit	Test Conditions/Comments
	+25°C	-40°C to +85°C		
<b>ANALOG SWITCH</b>				
Analog Signal Range		0 V to $V_{DD}$	V	
ON Resistance ( $R_{ON}$ )	3		$\Omega$ typ	$V_S = 0\text{ V to }V_{DD}$ , $I_{DS} = 10\text{ mA}$ ; Test Circuit 1
	4.5	5	$\Omega$ max	
ON Resistance Match Between Channels ( $\Delta R_{ON}$ )		0.4	$\Omega$ typ	
		0.8	$\Omega$ max	$V_S = 0\text{ V to }V_{DD}$ , $I_{DS} = 10\text{ mA}$
ON Resistance Flatness ( $R_{FLAT(ON)}$ )	0.75		$\Omega$ typ	$V_S = 0\text{ V to }V_{DD}$ , $I_{DS} = 10\text{ mA}$
		1.2	$\Omega$ max	
<b>LEAKAGE CURRENTS</b>				
Source OFF Leakage $I_S$ (OFF)	$\pm 0.01$		nA typ	$V_{DD} = 5.5\text{ V}$ $V_D = 4.5\text{ V/1 V}$ , $V_S = 1\text{ V/4.5 V}$ ; Test Circuit 2
	$\pm 0.1$	$\pm 0.3$	nA max	
Drain OFF Leakage $I_D$ (OFF)	$\pm 0.01$		nA typ	$V_D = 4.5\text{ V/1 V}$ , $V_S = 1\text{ V/4.5 V}$ ; Test Circuit 3
	$\pm 0.1$	$\pm 0.75$	nA max	
Channel ON Leakage $I_D$ , $I_S$ (ON)	$\pm 0.01$		nA typ	$V_D = V_S = 1\text{ V}$ , or 4.5 V, Test Circuit 4
	$\pm 0.1$	$\pm 0.75$	nA max	
<b>DIGITAL INPUTS</b>				
Input High Voltage, $V_{INH}$		2.4	V min	
Input Low Voltage, $V_{INL}$		0.8	V max	
Input Current $I_{INL}$ or $I_{INH}$	0.005		$\mu\text{A}$ typ	$V_{IN} = V_{INL}$ or $V_{INH}$
		$\pm 0.1$	$\mu\text{A}$ max	
$C_{IN}$ , Digital Input Capacitance	2		pF typ	
<b>DYNAMIC CHARACTERISTICS<sup>2</sup></b>				
$t_{TRANSITION}$	14		ns typ	$R_L = 300\ \Omega$ , $C_L = 35\text{ pF}$ ; Test Circuit 5
		25	ns max	$V_{S1} = 3\text{ V/0 V}$ , $V_{S8} = 0\text{ V/3 V}$
Break-Before-Make Time Delay, $t_D$	8		ns typ	$R_L = 300\ \Omega$ , $C_L = 35\text{ pF}$
		1	ns min	$V_S = 3\text{ V}$ ; Test Circuit 6
$t_{ON}$ (EN)	14		ns typ	$R_L = 300\ \Omega$ , $C_L = 35\text{ pF}$
		25	ns max	$V_S = 3\text{ V}$ ; Test Circuit 7
$t_{OFF}$ (EN)	7		ns typ	$R_L = 300\ \Omega$ , $C_L = 35\text{ pF}$
		12	ns max	$V_S = 3\text{ V}$ ; Test Circuit 7
Charge Injection	$\pm 3$		pC typ	$V_S = 2.5\text{ V}$ , $R_S = 0\ \Omega$ , $C_L = 1\text{ nF}$ ; Test Circuit 8
Off Isolation	-60		dB typ	$R_L = 50\ \Omega$ , $C_L = 5\text{ pF}$ , $f = 10\text{ MHz}$
	-80		dB typ	$R_L = 50\ \Omega$ , $C_L = 5\text{ pF}$ , $f = 1\text{ MHz}$ ; Test Circuit 9
Channel-to-Channel Crosstalk	-60		dB typ	$R_L = 50\ \Omega$ , $C_L = 5\text{ pF}$ , $f = 10\text{ MHz}$
	-80		dB typ	$R_L = 50\ \Omega$ , $C_L = 5\text{ pF}$ , $f = 1\text{ MHz}$ ; Test Circuit 10
-3 dB Bandwidth	55		MHz typ	$R_L = 50\ \Omega$ , $C_L = 5\text{ pF}$ ; Test Circuit 11
$C_S$ (OFF)	13		pF typ	$f = 1\text{ MHz}$
$C_D$ (OFF)				
ADG758	85		pF typ	$f = 1\text{ MHz}$
ADG759	42		pF typ	$f = 1\text{ MHz}$
$C_D$ , $C_S$ (ON)				
ADG758	96		pF typ	$f = 1\text{ MHz}$
ADG759	48		pF typ	$f = 1\text{ MHz}$
<b>POWER REQUIREMENTS</b>				
$I_{DD}$	0.001		$\mu\text{A}$ typ	$V_{DD} = 5.5\text{ V}$ Digital Inputs = 0 V or 5.5 V
		1.0	$\mu\text{A}$ max	

## NOTES

<sup>1</sup>Temperature range is as follows: B Version: -40°C to +85°C.

<sup>2</sup>Guaranteed by design, not subject to production test.

Specifications subject to change without notice.

SPECIFICATIONS<sup>1</sup>(V<sub>DD</sub> = 3 V ± 10%, V<sub>SS</sub> = 0 V, GND = 0 V, unless otherwise noted.)

Parameter	B Version		Unit	Test Conditions/Comments
	+25°C	-40°C to +85°C		
<b>ANALOG SWITCH</b>				
Analog Signal Range		0 V to V <sub>DD</sub>	V	
ON Resistance (R <sub>ON</sub> )	8		Ω typ	V <sub>S</sub> = 0 V to V <sub>DD</sub> , I <sub>DS</sub> = 10 mA;
	11	12	Ω max	Test Circuit 1
ON Resistance Match Between Channels (ΔR <sub>ON</sub> )		0.4	Ω typ	V <sub>S</sub> = 0 V to V <sub>DD</sub> , I <sub>DS</sub> = 10 mA
		1.2	Ω max	
<b>LEAKAGE CURRENTS</b>				
Source OFF Leakage I <sub>S</sub> (OFF)	±0.01		nA typ	V <sub>DD</sub> = 3.3 V
	±0.1	±0.3	nA max	V <sub>S</sub> = 3 V/1 V, V <sub>D</sub> = 1 V/3 V;
Drain OFF Leakage I <sub>D</sub> (OFF)	±0.01		nA typ	Test Circuit 2
	±0.1	±0.75	nA max	V <sub>S</sub> = 3 V/1 V, V <sub>D</sub> = 1 V/3 V;
Channel ON Leakage I <sub>D</sub> , I <sub>S</sub> (ON)	±0.01		nA typ	Test Circuit 3
	±0.1	±0.75	nA max	V <sub>S</sub> = V <sub>D</sub> = 1 V or 3 V; Test Circuit 4
<b>DIGITAL INPUTS</b>				
Input High Voltage, V <sub>INH</sub>		2.0	V min	
Input Low Voltage, V <sub>INL</sub>		0.8	V max	
Input Current				
I <sub>INL</sub> or I <sub>INH</sub>	0.005		μA typ	V <sub>IN</sub> = V <sub>INL</sub> or V <sub>INH</sub>
		±0.1	μA max	
C <sub>IN</sub> , Digital Input Capacitance	2		pF typ	
<b>DYNAMIC CHARACTERISTICS<sup>2</sup></b>				
t <sub>TRANSITION</sub>	18		ns typ	R <sub>L</sub> = 300 Ω, C <sub>L</sub> = 35 pF; Test Circuit 5
		30	ns max	V <sub>S1</sub> = 2 V/0 V, V <sub>S2</sub> = 0 V/2 V
Break-Before-Make Time Delay, t <sub>D</sub>	8		ns typ	R <sub>L</sub> = 300 Ω, C <sub>L</sub> = 35 pF
		1	ns min	V <sub>S</sub> = 2 V; Test Circuit 6
t <sub>ON</sub> (EN)	18		ns typ	R <sub>L</sub> = 300 Ω, C <sub>L</sub> = 35 pF
		30	ns max	V <sub>S</sub> = 2 V; Test Circuit 7
t <sub>OFF</sub> (EN)	8		ns typ	R <sub>L</sub> = 300 Ω, C <sub>L</sub> = 35 pF
		15	ns max	V <sub>S</sub> = 2 V; Test Circuit 7
Charge Injection	±3		pC typ	V <sub>S</sub> = 1.5 V, R <sub>S</sub> = 0 Ω, C <sub>L</sub> = 1 nF;
				Test Circuit 8
Off Isolation	-60		dB typ	R <sub>L</sub> = 50 Ω, C <sub>L</sub> = 5 pF, f = 10 MHz
	-80		dB typ	R <sub>L</sub> = 50 Ω, C <sub>L</sub> = 5 pF, f = 1 MHz;
				Test Circuit 9
Channel-to-Channel Crosstalk	-60		dB typ	R <sub>L</sub> = 50 Ω, C <sub>L</sub> = 5 pF, f = 10 MHz
	-80		dB typ	R <sub>L</sub> = 50 Ω, C <sub>L</sub> = 5 pF, f = 1 MHz;
				Test Circuit 10
-3 dB Bandwidth	55		MHz typ	R <sub>L</sub> = 50 Ω, C <sub>L</sub> = 5 pF; Test Circuit 11
C <sub>S</sub> (OFF)	13		pF typ	f = 1 MHz
C <sub>D</sub> (OFF)				
ADG758	85		pF typ	f = 1 MHz
ADG759	42		pF typ	f = 1 MHz
C <sub>D</sub> , C <sub>S</sub> (ON)				
ADG758	96		pF typ	f = 1 MHz
ADG759	48		pF typ	f = 1 MHz
<b>POWER REQUIREMENTS</b>				
I <sub>DD</sub>	0.001		μA typ	V <sub>DD</sub> = 3.3 V
		1.0	μA max	Digital Inputs = 0 V or 3.3 V

## NOTES

<sup>1</sup>Temperature ranges are as follows: B Version: -40°C to +85°C.<sup>2</sup>Guaranteed by design, not subject to production test.

Specifications subject to change without notice.

# ADG758/ADG759—SPECIFICATIONS<sup>1</sup>

**DUAL SUPPLY** ( $V_{DD} = +2.5\text{ V} \pm 10\%$ ,  $V_{SS} = -2.5\text{ V} \pm 10\%$ ,  $GND = 0\text{ V}$ , unless otherwise noted.)

Parameter	B Version		Unit	Test Conditions/Comments
	+25°C	-40°C to +85°C		
<b>ANALOG SWITCH</b>				
Analog Signal Range		$V_{SS}$ to $V_{DD}$	V	
ON Resistance ( $R_{ON}$ )	2.5		$\Omega$ typ	$V_S = V_{SS}$ to $V_{DD}$ , $I_{DS} = 10\text{ mA}$ ; Test Circuit 1
	4.5	5	$\Omega$ max	
ON Resistance Match Between Channels ( $\Delta R_{ON}$ )		0.4	$\Omega$ typ	$V_S = V_{SS}$ to $V_{DD}$ , $I_{DS} = 10\text{ mA}$
		0.8	$\Omega$ max	$V_S = V_{SS}$ to $V_{DD}$ , $I_{DS} = 10\text{ mA}$
ON Resistance Flatness ( $R_{FLAT(ON)}$ )	0.6		$\Omega$ typ	$V_S = V_{SS}$ to $V_{DD}$ , $I_{DS} = 10\text{ mA}$
		1.0	$\Omega$ max	
<b>LEAKAGE CURRENTS</b>				
Source OFF Leakage $I_S$ (OFF)	$\pm 0.01$		nA typ	$V_{DD} = +2.75\text{ V}$ , $V_{SS} = -2.75\text{ V}$ $V_S = +2.25\text{ V}/-1.25\text{ V}$ , $V_D = -1.25\text{ V}/+2.25\text{ V}$ ; Test Circuit 2
	$\pm 0.1$	$\pm 0.3$	nA max	
Drain OFF Leakage $I_D$ (OFF)	$\pm 0.01$		nA typ	$V_S = +2.25\text{ V}/-1.25\text{ V}$ , $V_D = -1.25\text{ V}/+2.25\text{ V}$ ; Test Circuit 3
	$\pm 0.1$	$\pm 0.75$	nA max	
Channel ON Leakage $I_D$ , $I_S$ (ON)	$\pm 0.01$		nA typ	$V_S = V_D = +2.25\text{ V}/-1.25\text{ V}$ ; Test Circuit 4
	$\pm 0.1$	$\pm 0.75$	nA max	
<b>DIGITAL INPUTS</b>				
Input High Voltage, $V_{INH}$		1.7	V min	
Input Low Voltage, $V_{INL}$		0.7	V max	
Input Current $I_{INL}$ or $I_{INH}$	0.005		$\mu\text{A}$ typ	$V_{IN} = V_{INL}$ or $V_{INH}$
		$\pm 0.1$	$\mu\text{A}$ max	
$C_{IN}$ , Digital Input Capacitance	2		pF typ	
<b>DYNAMIC CHARACTERISTICS<sup>2</sup></b>				
$t_{TRANSITION}$	14		ns typ	$R_L = 300\ \Omega$ , $C_L = 35\text{ pF}$ ; Test Circuit 5
		25	ns max	$V_S = 1.5\text{ V}/0\text{ V}$ ; Test Circuit 5
Break-Before-Make Time Delay, $t_D$	8		ns typ	$R_L = 300\ \Omega$ , $C_L = 35\text{ pF}$
		1	ns min	$V_S = 1.5\text{ V}$ ; Test Circuit 6
$t_{ON}$ (EN)	14		ns typ	$R_L = 300\ \Omega$ , $C_L = 35\text{ pF}$
		25	ns max	$V_S = 1.5\text{ V}$ ; Test Circuit 7
$t_{OFF}$ (EN)	8		ns typ	$R_L = 300\ \Omega$ , $C_L = 35\text{ pF}$
		15	ns max	$V_S = 1.5\text{ V}$ ; Test Circuit 7
Charge Injection	$\pm 3$		pC typ	$V_S = 0\text{ V}$ , $R_S = 0\ \Omega$ , $C_L = 1\text{ nF}$ ; Test Circuit 8
Off Isolation	-60		dB typ	$R_L = 50\ \Omega$ , $C_L = 5\text{ pF}$ , $f = 10\text{ MHz}$
	-80		dB typ	$R_L = 50\ \Omega$ , $C_L = 5\text{ pF}$ , $f = 1\text{ MHz}$ ; Test Circuit 9
Channel-to-Channel Crosstalk	-60		dB typ	$R_L = 50\ \Omega$ , $C_L = 5\text{ pF}$ , $f = 10\text{ MHz}$
	-80		dB typ	$R_L = 50\ \Omega$ , $C_L = 5\text{ pF}$ , $f = 1\text{ MHz}$ ; Test Circuit 10
-3 dB Bandwidth	55		MHz typ	$R_L = 50\ \Omega$ , $C_L = 5\text{ pF}$ ; Test Circuit 11
$C_S$ (OFF)	13		pF typ	$f = 1\text{ MHz}$
$C_D$ (OFF)				
ADG758	85		pF typ	$f = 1\text{ MHz}$
ADG759	42		pF typ	$f = 1\text{ MHz}$
$C_D$ , $C_S$ (ON)				
ADG758	96		pF typ	$f = 1\text{ MHz}$
ADG759	48		pF typ	$f = 1\text{ MHz}$
<b>POWER REQUIREMENTS</b>				
$I_{DD}$	0.001		$\mu\text{A}$ typ	$V_{DD} = +2.75\text{ V}$ Digital Inputs = 0 V or 2.75 V
		1.0	$\mu\text{A}$ max	
$I_{SS}$	0.001		$\mu\text{A}$ typ	$V_{SS} = -2.75\text{ V}$ Digital Inputs = 0 V or 2.75 V
		1.0	$\mu\text{A}$ max	

## NOTES

<sup>1</sup>Temperature range is as follows: B Version: -40°C to +85°C.

<sup>2</sup>Guaranteed by design, not subject to production test.

Specifications subject to change without notice.

# ABSOLUTE MAXIMUM RATINGS

T<sub>A</sub> = 25°C, unless otherwise noted.

Parameter	Rating
V <sub>DD</sub> to V <sub>SS</sub>	7 V
V <sub>DD</sub> to GND	-0.3 V to +7 V
V <sub>SS</sub> to GND	+0.3 V to -3.5 V
Analog Inputs <sup>1</sup>	V <sub>SS</sub> - 0.3 V to V <sub>DD</sub> +0.3 V or 30 mA, Whichever Occurs First
Digital Inputs <sup>1</sup>	-0.3 V to V <sub>DD</sub> +0.3 V or 30 mA, Whichever Occurs First
Peak Current, S or D	100 mA (Pulsed at 1 ms, 10% Duty Cycle max)
Continuous Current, S or D	30 mA
Operating Temperature Range	
Industrial (B Version)	-40°C to +85°C
Storage Temperature Range	-65°C to +150°C
Junction Temperature	150°C
Chip Scale Package, θ <sub>JA</sub> Thermal Impedance	32°C/W
Lead Temperature, Soldering	
Vapor Phase (60 sec)	215°C
Infrared (15 sec)	220°C

<sup>1</sup> Overvoltages at EN, A, S, or D will be clamped by internal diodes. Current should be limited to the maximum ratings given.

## ESD CAUTION

ESD (electrostatic discharge) sensitive device. Electrostatic charges as high as 4000 V readily accumulate on the human body and test equipment and can discharge without detection. Although this product features proprietary ESD protection circuitry, permanent damage may occur on devices subjected to high energy electrostatic discharges. Therefore, proper ESD precautions are recommended to avoid performance degradation or loss of functionality.



Table I. ADG758 Truth Table

A2	A1	A0	EN	Switch Condition
X	X	X	0	NONE
0	0	0	1	1
0	0	1	1	2
0	1	0	1	3
0	1	1	1	4
1	0	0	1	5
1	0	1	1	6
1	1	0	1	7
1	1	1	1	8

X = Don't Care

Table II. ADG759 Truth Table

A1	A0	EN	ON Switch Pair
X	X	0	NONE
0	0	1	1
0	1	1	2
1	0	1	3
1	1	1	4

X = Don't Care

Stresses above those listed under Absolute Maximum Ratings may cause permanent damage to the device. This is a stress rating only; functional operation of the device at these or any other conditions above those indicated in the operational section of this specification is not implied. Exposure to absolute maximum rating conditions for extended periods may affect device reliability.

## PIN CONFIGURATIONS

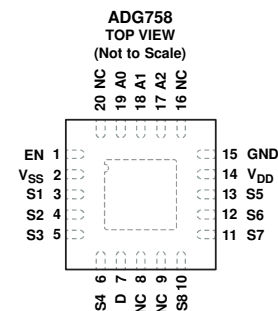

- NOTES  
1. NC = NO CONNECT.  
2. EXPOSED PAD TIED TO SUBSTRATE, V<sub>SS</sub>.

02371-102

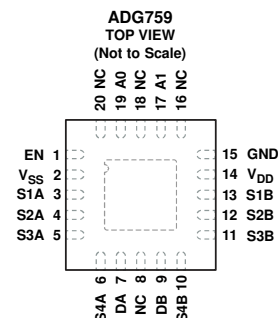

- NOTES  
1. NC = NO CONNECT.  
2. EXPOSED PAD TIED TO SUBSTRATE, V<sub>SS</sub>.

02371-103

## TERMINOLOGY

$V_{DD}$	Most Positive Power Supply Potential
$V_{SS}$	Most Negative Power Supply in a dual-supply application. In single-supply applications, this should be tied to ground at the device.
GND	Ground (0 V) Reference
S	Source Terminal. May be an input or output.
D	Drain Terminal. May be an input or output.
IN	Logic Control Input
$R_{ON}$	Ohmic Resistance between D and S
$R_{FLAT(ON)}$	Flatness is defined as the difference between the maximum and minimum value of ON resistance as measured over the specified analog signal range.
$I_S$ (OFF)	Source Leakage Current with the Switch OFF
$I_D$ (OFF)	Drain leakage Current with the Switch OFF
$I_D, I_S$ (ON)	Channel Leakage current with the Switch ON
$V_D$ ( $V_S$ )	Analog Voltage on Terminals D, S
$C_S$ (OFF)	OFF Switch Source Capacitance. Measured with reference to ground.
$C_D$ (OFF)	OFF Switch Drain Capacitance. Measured with reference to ground.
$C_D, C_S$ (ON)	ON Switch Capacitance. Measured with reference to ground.
$C_{IN}$	Digital Input Capacitance
$t_{TRANSITION}$	Delay Time measured between the 50% and 90% points of the digital inputs and the switch ON condition when switching from one address state to another.
$t_{ON}$ (EN)	Delay Time between the 50% and 90% points of the EN digital input and the switch ON condition.
$t_{OFF}$ (EN)	Delay Time between the 50% and 90% points of the EN digital input and the switch OFF condition.
$t_{OPEN}$	OFF Time measured between the 80% points of both switches when switching from one address state to another.
Off Isolation	A measure of unwanted signal coupling through an OFF switch.
Crosstalk	A measure of unwanted signal which is coupled through from one channel to another as a result of parasitic capacitance.
Charge Injection	A measure of the glitch impulse transferred from the digital input to the analog output during switching.
On Response	The Frequency Response of the ON Switch.
On Loss	The Loss Due to the ON Resistance of the Switch
$V_{INL}$	Maximum Input Voltage for Logic "0"
$V_{INH}$	Minimum Input Voltage for Logic "1"
$I_{INL}$ ( $I_{INH}$ )	Input Current of the Digital Input
$I_{DD}$	Positive Supply Current
$I_{SS}$	Negative Supply Current

# Typical Performance Characteristics—ADG758/ADG759

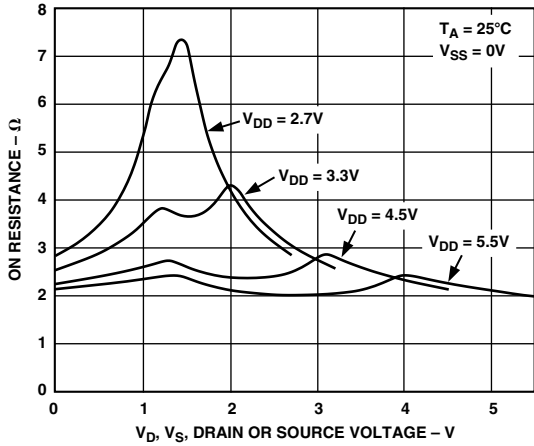

TPC 1. ON Resistance as a Function of  $V_D$  ( $V_S$ ) for Single Supply

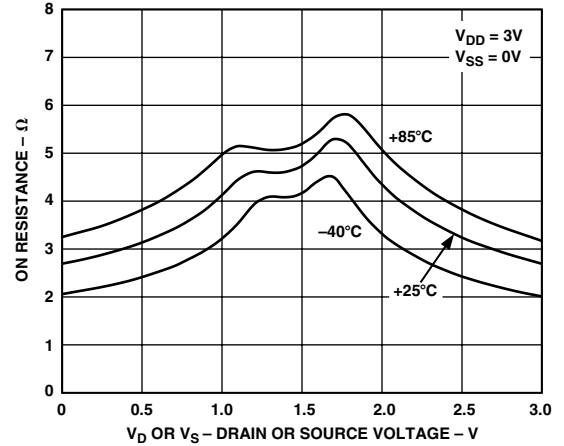

TPC 4. ON Resistance as a Function of  $V_D$  ( $V_S$ ) for Different Temperatures, Single Supply

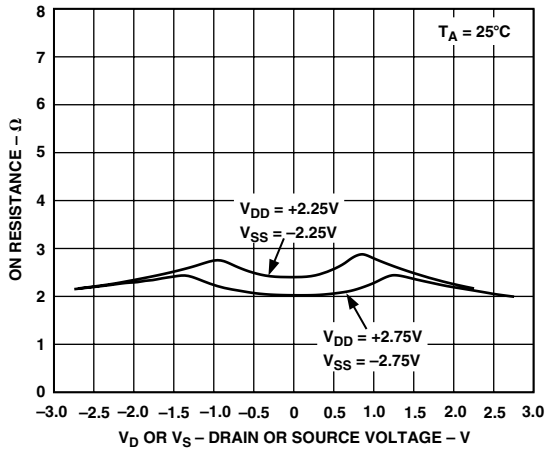

TPC 2. ON Resistance as a Function of  $V_D$  ( $V_S$ ) for Dual Supply

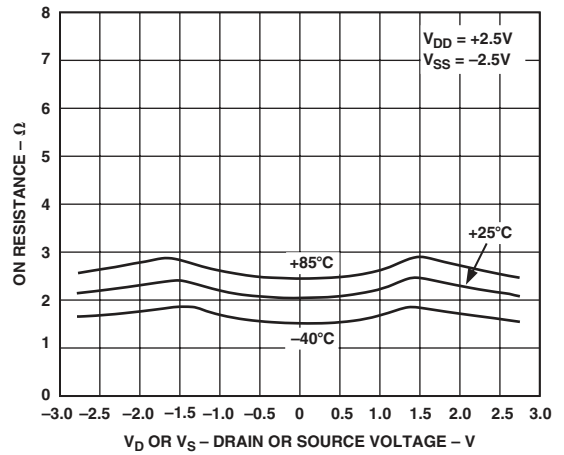

TPC 5. ON Resistance as a Function of  $V_D$  ( $V_S$ ) for Different Temperatures, Dual Supply

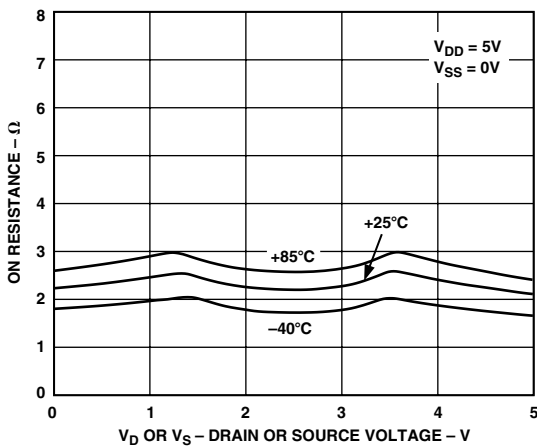

TPC 3. ON Resistance as a Function of  $V_D$  ( $V_S$ ) for Different Temperatures, Single Supply

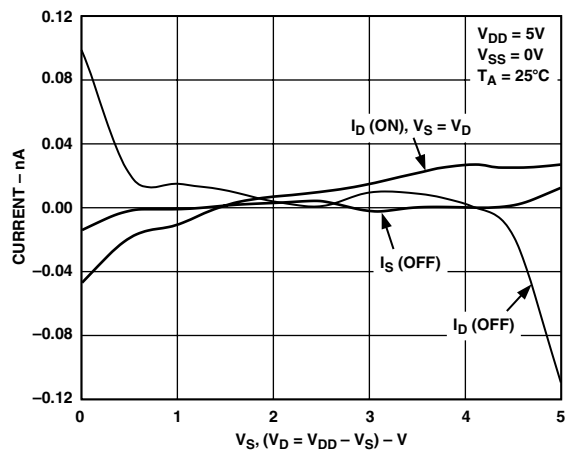

TPC 6. Leakage Currents as a Function of  $V_D$  ( $V_S$ )

# ADG758/ADG759

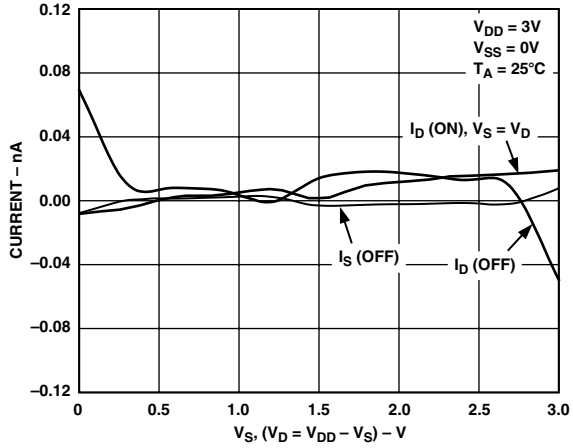

TPC 7. Leakage Currents as a Function of  $V_D$  ( $V_S$ )

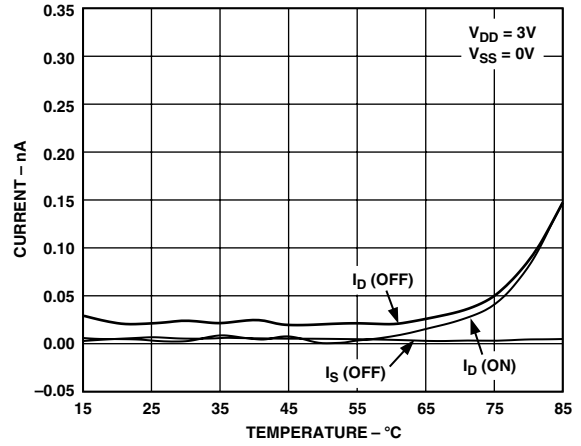

TPC 10. Leakage Currents as a Function of Temperature

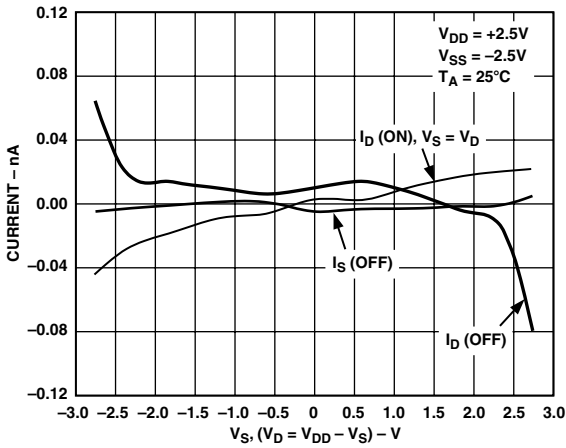

TPC 8. Leakage Currents as a Function of  $V_D$  ( $V_S$ )

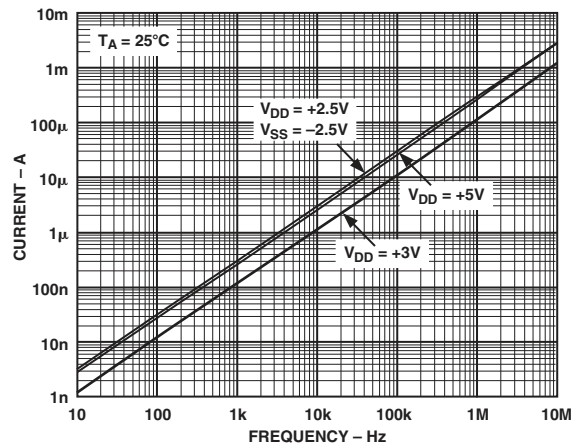

TPC 11. Supply Current vs. Input Switching Frequency

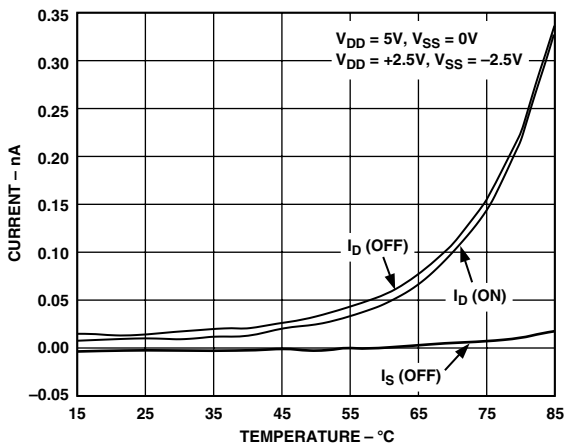

TPC 9. Leakage Currents as a Function of Temperature

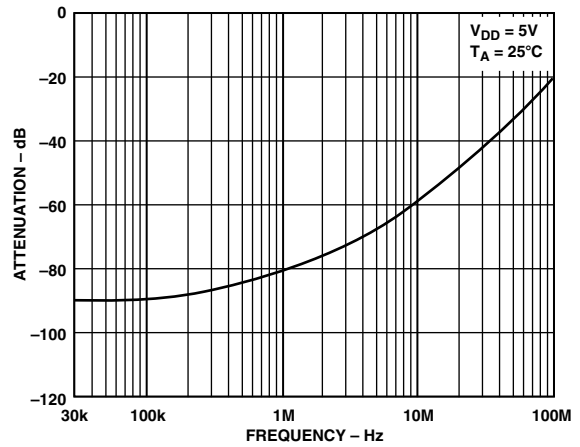

TPC 12. OFF Isolation vs. Frequency



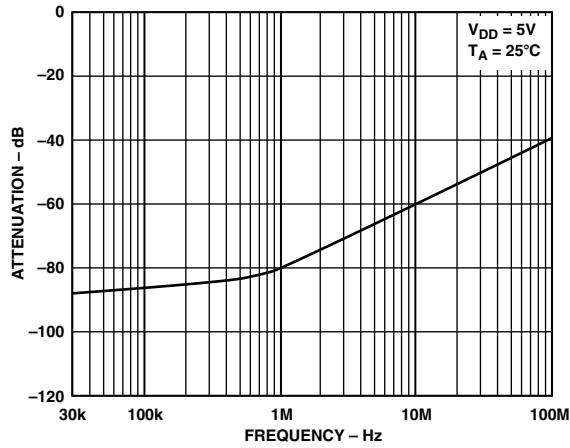

TPC 13. Crosstalk vs. Frequency

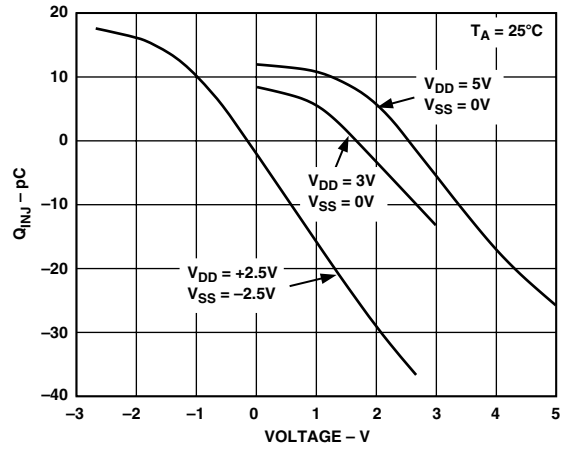

TPC 15. Charge Injection vs. Source Voltage

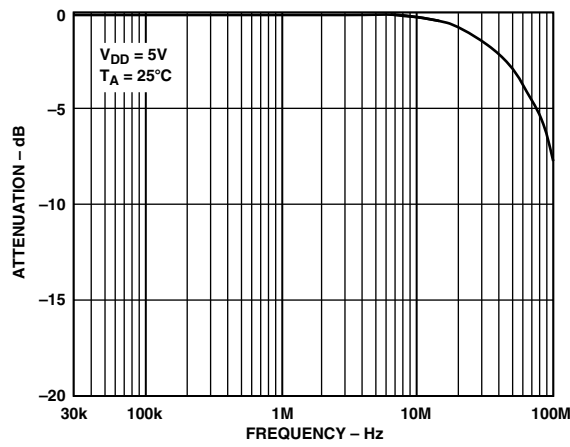

TPC 14. ON Response vs. Frequency

# ADG758/ADG759

## Test Circuits

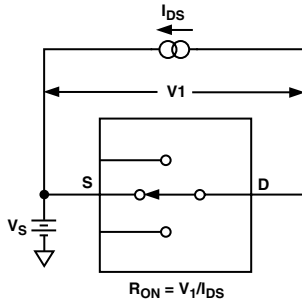

Test Circuit 1. ON Resistance

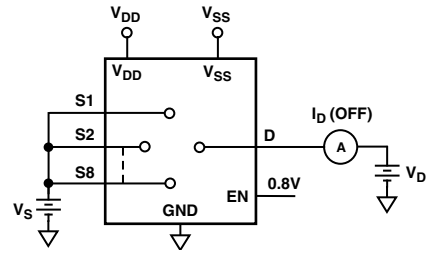

Test Circuit 3.  $I_D$  (OFF)

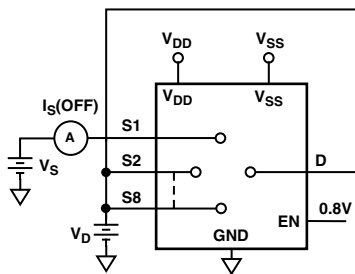

Test Circuit 2.  $I_S$  (OFF)

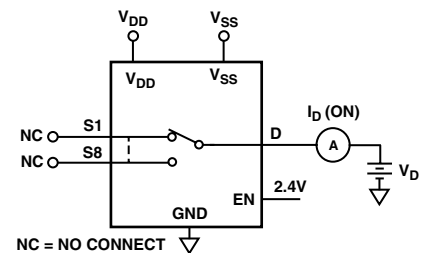

Test Circuit 4.  $I_D$  (ON)

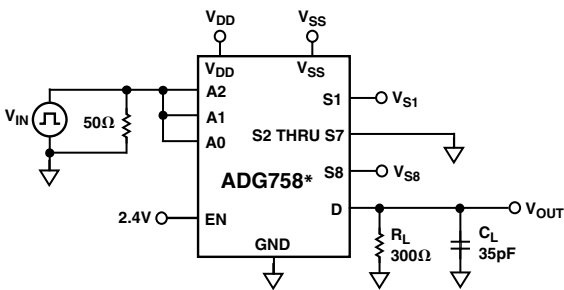

\*SIMILAR CONNECTION FOR ADG759

Test Circuit 5. Switching Time of Multiplexer,  $t_{\text{TRANSITION}}$

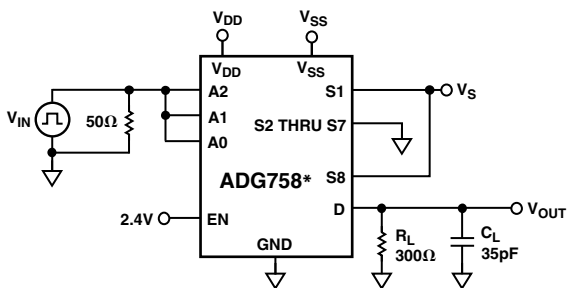
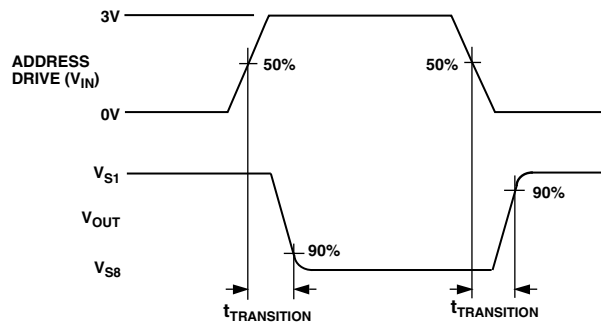

\*SIMILAR CONNECTION FOR ADG759

Test Circuit 6. Break-Before-Make Delay,  $t_{\text{OPEN}}$

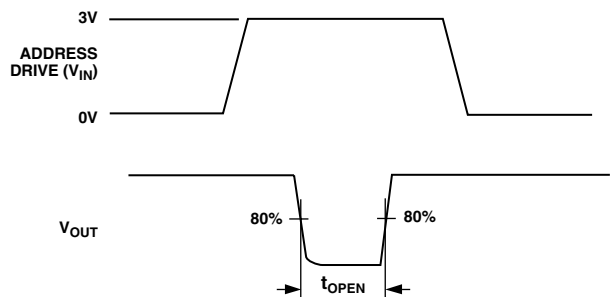

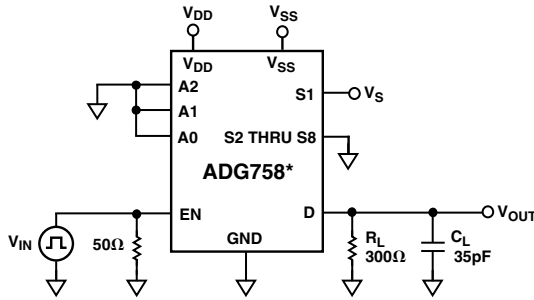

\*SIMILAR CONNECTION FOR ADG759

Test Circuit 7. Enable Delay,  $t_{ON}(EN)$ ,  $t_{OFF}(EN)$

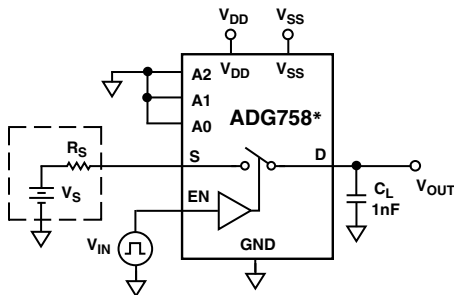
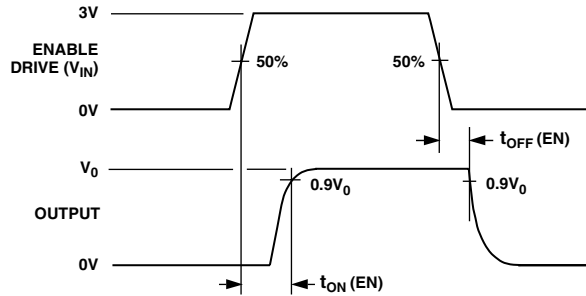

\*SIMILAR CONNECTION FOR ADG759

Test Circuit 8. Charge Injection

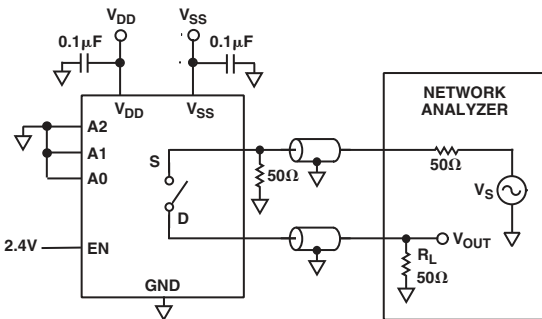
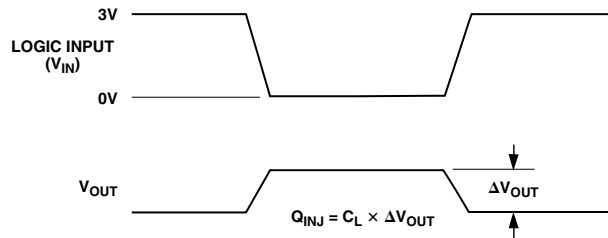

$$\text{OFF ISOLATION} = 20 \text{ LOG } \frac{V_{OUT}}{V_S}$$

Test Circuit 9. OFF Isolation

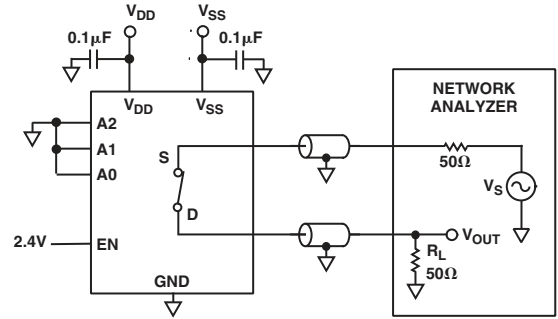

$$\text{INSERTION LOSS} = 20 \text{ LOG } \frac{V_{OUT \text{ WITH SWITCH}}}{V_{OUT \text{ WITHOUT SWITCH}}}$$

Test Circuit 11. Bandwidth

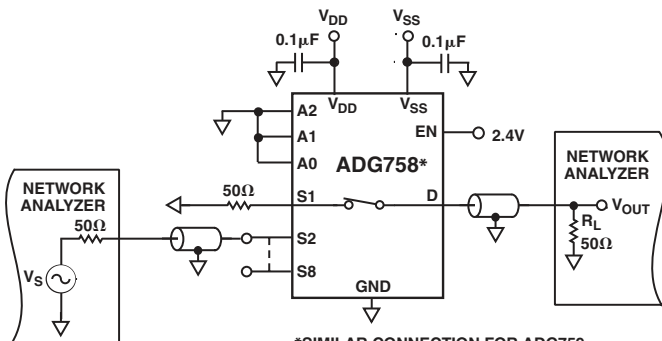

\*SIMILAR CONNECTION FOR ADG759

CHANNEL-TO-CHANNEL

$$\text{CROSSTALK} = 20 \text{ LOG } \frac{V_{OUT}}{V_S}$$

Test Circuit 10. Channel-to-Channel Crosstalk

## Power-Supply Sequencing

When using CMOS devices, care must be taken to ensure correct power-supply sequencing. Incorrect power-supply sequencing can result in the device being subjected to stresses beyond the maximum ratings listed in the data sheet. Digital and analog inputs should always be applied after power supplies and ground. For single-supply operation,  $V_{SS}$  should be tied to GND as close to the device as possible.

## OUTLINE DIMENSIONS

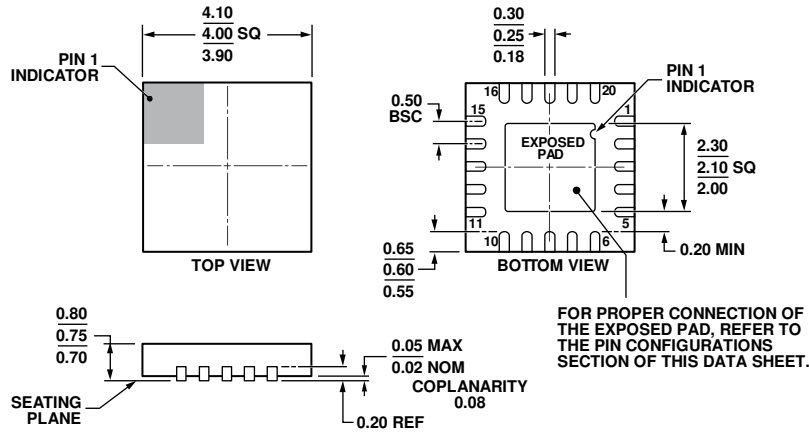

COMPLIANT TO JEDEC STANDARDS MO-220-WGGD-1.

20-Lead Lead Frame Chip Scale Package [LFCSP\_WQ]

4 mm × 4 mm Body, Very Very Thin Quad

(CP-20-6)

Dimensions shown in millimeters

08-16-2010-B

## ORDERING GUIDE

Model <sup>1</sup>	Temperature Range	Package Description	Package Option
ADG758BCPZ	-40°C to +85°C	20-Lead Lead Frame Chip Scale Package (LFCSP_WQ)	CP-20-6
ADG758BCPZ-REEL7	-40°C to +85°C	20-Lead Lead Frame Chip Scale Package (LFCSP_WQ)	CP-20-6
ADG759BCPZ	-40°C to +85°C	20-Lead Lead Frame Chip Scale Package (LFCSP_WQ)	CP-20-6
ADG759BCPZ-REEL	-40°C to +85°C	20-Lead Lead Frame Chip Scale Package (LFCSP_WQ)	CP-20-6
ADG759BCPZ-REEL7	-40°C to +85°C	20-Lead Lead Frame Chip Scale Package (LFCSP_WQ)	CP-20-6

<sup>1</sup> Z = RoHS Compliant Part.

## REVISION HISTORY

### 3/13—Rev. A to Rev. B

Updated Outline Dimensions..... 12

Changes to Ordering Guide..... 12

### 5/02—Rev. 0 to Rev. A

Edits to General Description section..... 1

Updated Outline Drawings..... 12