

## 18-Bit Universal Bus Transceiver With 3-State Outputs

### Product Features

- PI74ALVCH162601 is designed for low voltage operation
- $V_{CC} = 2.3V$  to  $3.6V$
- Hysteresis on all inputs
- Typical  $V_{OLP}$  (Output Ground Bounce)  
<  $0.8V$  at  $V_{CC} = 3.3V, T_A = 25^\circ C$
- Typical  $V_{OHV}$  (Output  $V_{OH}$  Undershoot)  
<  $2.0V$  at  $V_{CC} = 3.3V, T_A = 25^\circ C$
- Bus Hold retains last active bus state during 3-STATE, eliminating the need for external pullup resistors
- Industrial operation at  $-40^\circ C$  to  $+85^\circ C$
- Packages available:
  - 56-pin 240 mil wide plastic TSSOP (A)
  - 56-pin 300 mil wide plastic SSOP (V)

### Product Description

Pericom Semiconductor's PI74ALVCH series of logic circuits are produced in the Company's advanced 0.5 micron CMOS technology, achieving industry leading speed.

The PI74ALVCH162601 uses D-type latches and D-type flip-flops with 3-state outputs to allow data flow in transparent, latched, and clocked modes.

Data flow in each direction is controlled by Output Enable ( $\overline{OEAB}$  and  $\overline{OEBA}$ ), Latched Enable ( $\overline{LEAB}$  and  $\overline{LEBA}$ ), and Clock ( $\overline{CLKAB}$  and  $\overline{CLKBA}$ ) inputs. The clock can be controlled by the Clock Enable ( $\overline{CLKENAB}$  and  $\overline{CLKENBA}$ ) inputs. For A-to-B data flow, the device operates in the transparent mode when  $\overline{LEAB}$  is HIGH. When  $\overline{LEAB}$  is LOW, the A data is latched if  $\overline{CLKAB}$  is held at a high or low logic level. If  $\overline{LEAB}$  is low, the A-bus is stored in the latch/flip-flop on the low-to-high transition of  $\overline{CLKAB}$ . When  $\overline{OEAB}$  is low, the outputs are active. When  $\overline{OEAB}$  is HIGH, the outputs are in the high-impedance state.

Data flow for B to A is similar to that of A to B but uses  $\overline{OEBA}$ ,  $\overline{LEBA}$ ,  $\overline{CLKBA}$ , and  $\overline{CLKENBA}$ .

To reduce overshoot and undershoot, the B-port outputs include  $26\Omega$  series resistors.

To ensure the high-impedance state during power up or power down,  $\overline{OE}$  should be tied to  $V_{CC}$  through a pull-up resistor; the minimum value of the resistor is determined by the current-sinking capability of the driver.

The PI74ALVCH162601 has "Bus Hold" which retains the data input's last state whenever the data input goes to high-impedance preventing "floating" inputs and eliminating the need for pullup/down resistors.

### Logic Block Diagram

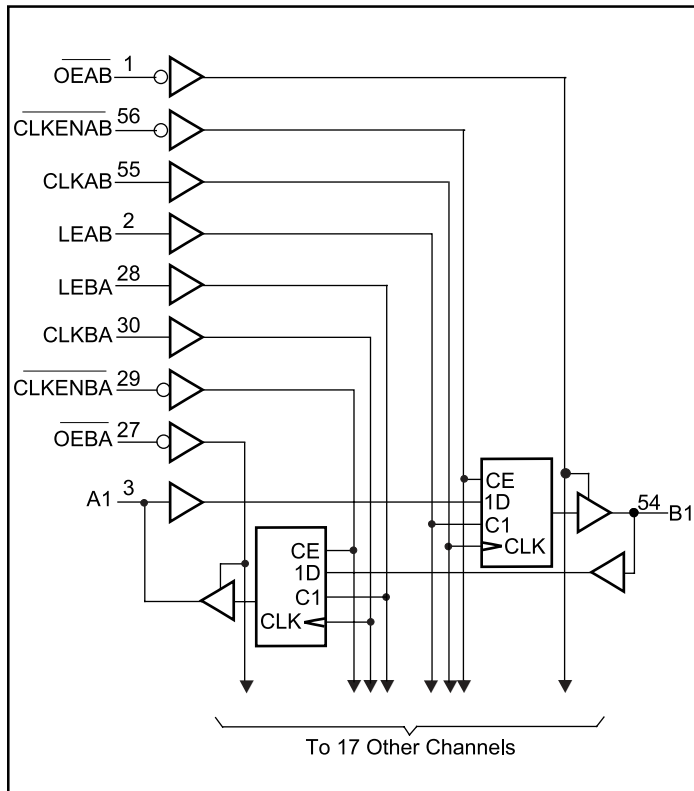

### Product Pin Description

Pin Name	Description
$\overline{\text{CLKEN}}$	Clock Enable Input (Active LOW)
$\overline{\text{OE}}$	Output Enable Input (Active LOW)
LE	Latch Enable (Active HIGH)
CLK	Clock Input (Active HIGH)
Ax	Data I/O
Bx	Data I/O
GND	Ground
Vcc	Power

### Truth Table<sup>(1)†</sup>

Inputs					Output B
CLKENAB	OEAB	LEAB	CLKAB	A	
X	H	X	X	X	Z
X	L	H	X	L	L
X	L	H	X	H	H
H	L	L	X	X	B <sub>0</sub> ‡
H	L	L	X	X	B <sub>0</sub> ‡
L	L	L	↑	L	L
L	L	L	↑	H	H
L	L	L	L	X	B <sub>0</sub> ‡
L	L	L	H	X	B <sub>0</sub> §

### Product Pin Configuration

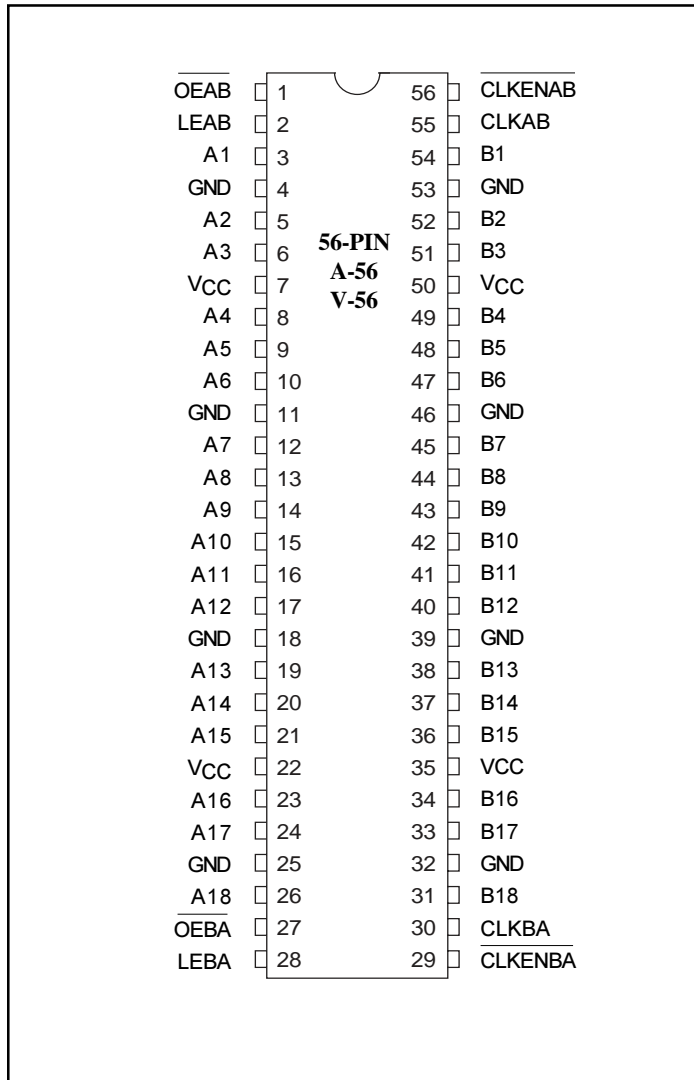

#### Notes:

- H = High Signal Level  
L = Low Signal Level  
Z = High Impedance  
↑ = LOW-to-HIGH Transition
- † A-to-B data flow is shown: B-to-A flow is similar but uses OEBA, LEBA, CLKBA, and CLKENBA.
- ‡ Output level before the indicated steady-state input conditions were established.
- § Output level before the indicated steady-state input conditions were established, provided that CLKAB is LOW before LEAB goes LOW.

### Maximum Ratings

(Above which the useful life may be impaired. For user guidelines, not tested.)

Storage Temperature .....	-65°C to +150°C
Supply Voltage Range, V <sub>CC</sub> .....	-0.5V to 4.6V
Input Voltage Range, V <sub>I</sub> :	
Except I/O ports (See Note 1): .....	-0.5V to 4.6V
I/O ports (See Notes 1 and 2) .....	-0.5V to V <sub>CC</sub> +0.5V
Output Voltage Range, V <sub>O</sub> (See Notes 1 and 2) .....	-0.5V to V <sub>CC</sub> +0.5V
Input Clamp current, I <sub>IK</sub> (V <sub>I</sub> <0) .....	-50mA
Output Clamp current, I <sub>OK</sub> (V <sub>O</sub> <0 or V <sub>O</sub> >V <sub>CC</sub> ) .....	±50mA
Continuous Output Current, I <sub>O</sub> (V <sub>O</sub> =0 to V <sub>CC</sub> ) .....	±50mA
Continuous Current through each V <sub>CC</sub> or GND .....	±100mA
Maximum Power Dissipation:	
A package .....	1W
V package .....	1.4W

**Note:**

Stresses greater than those listed under MAXIMUM RATINGS may cause permanent damage to the device. This is a stress rating only and functional operation of the device at these or any other conditions above those indicated in the operational sections of this specification is not implied. Exposure to absolute maximum rating conditions for extended periods may affect reliability.

**Notes:**

1. The input and output negative-voltage ratings maybe exceeded if the input and output clamp-current ratings are observed.
2. This value is limited to 4.6V maximum.
3. The maximum package power dissipation is calculated using a junction temperature of 150°C and a board trace length of 750mils.

### Recommended Operating Conditions<sup>(1)</sup>

Parameters	Description	Test Conditions	Min.	Typ.	Max.	Units
V <sub>CC</sub>	Supply Voltage		2.3		3.6	V
V <sub>IH</sub>	Input HIGH Voltage	V <sub>CC</sub> = 2.3V to 2.7V	1.7			
		V <sub>CC</sub> = 2.7V to 3.6V	2.0			
V <sub>IL</sub>	Input LOW Voltage	V <sub>CC</sub> = 2.3V to 2.7V			0.7	
		V <sub>CC</sub> = 2.7V to 3.6V			0.8	
V <sub>IN</sub>	Input Voltage		0		V <sub>CC</sub>	
V <sub>OUT</sub>	Output Voltage		0		V <sub>CC</sub>	
I <sub>OH</sub>	High-level Output Current (A Port)	V <sub>CC</sub> = 2.3V			-12	mA
		V <sub>CC</sub> = 2.7V			-12	
		V <sub>CC</sub> = 3.0V			-24	
I <sub>OL</sub>	Low-level Output Current (A Port)	V <sub>CC</sub> = 2.3V			12	
		V <sub>CC</sub> = 2.7V			12	
		V <sub>CC</sub> = 3.0V			24	
I <sub>OH</sub>	High-level Output Current (B Port)	V <sub>CC</sub> = 2.3V			-6	
		V <sub>CC</sub> = 2.7V			-8	
		V <sub>CC</sub> = 3.0V			-12	
I <sub>OL</sub>	Low-level Output Current (B Port)	V <sub>CC</sub> = 2.3V			6	
		V <sub>CC</sub> = 2.7V			8	
		V <sub>CC</sub> = 3.0V			12	
T <sub>A</sub>	Operating Free-Air Temperature		-40		85	°C

**Note:**

1. Unused control inputs must be held HIGH or LOW to prevent them from floating.

**DC Electrical Characteristics** (Over the Operating Range,  $T_A = -40^\circ\text{C}$  to  $+85^\circ\text{C}$ ,  $V_{CC} = 3.3\text{V} \pm 10\%$ )

Parameters	Test Conditions		$V_{CC}^{(1)}$	Min.	Typ. <sup>(2)</sup>	Max.	Units
$V_{OH}$ (B Port)	$I_{OH} = -100 \mu\text{A}$		Min. to Max.	$V_{CC} - 0.2$			V
	$I_{OH} = -4 \text{ mA}$	$V_{IH} = 1.7\text{V}$	2.3V	1.9			
	$I_{OH} = -6 \text{ mA}$	$V_{IH} = 1.7\text{V}$	2.3V	1.7			
		$V_{IH} = 2.0\text{V}$	3.0V	2.4			
	$I_{OH} = -8 \text{ mA}$	$V_{IH} = 2.0\text{V}$	2.7V	2.0			
$I_{OH} = -12 \text{ mA}$	$V_{IH} = 2.0\text{V}$	3.0V	2.0				
$V_{OH}$ (A Port)	$I_{OH} = -100 \mu\text{A}$		Min. to Max.	$V_{CC} - 0.2$			V
	$I_{OH} = -6 \text{ mA}$	$V_{IH} = 1.7\text{V}$	2.3V	2.0			
	$I_{OH} = -12 \text{ mA}$	$V_{IH} = 1.7\text{V}$	2.3V	1.7			
		$V_{IH} = 2.0\text{V}$	2.7V	2.2			
	$I_{OH} = -24 \text{ mA}$	$V_{IH} = 2.0\text{V}$	3.0V	2.4			
$V_{OL}$ (B Port)	$I_{OL} = 100 \mu\text{A}$		Min. to Max.			0.2	V
	$I_{OL} = 4 \text{ mA}$	$V_{IL} = 0.7\text{V}$	2.3V			0.4	
	$I_{OL} = 6 \text{ mA}$	$V_{IL} = 0.7\text{V}$	2.3V			0.55	
		$V_{IL} = 0.8\text{V}$	3.0V			0.55	
	$I_{OL} = 8 \text{ mA}$	$V_{IL} = 0.8\text{V}$	2.7V			0.6	
$I_{OL} = 12 \text{ mA}$	$V_{IL} = 0.8\text{V}$	3.0V			0.8		
$V_{OL}$ (A Port)	$I_{OL} = 100 \mu\text{A}$		Min. to Max.			0.2	V
	$I_{OL} = 6 \text{ mA}$	$V_{IL} = 0.7\text{V}$	2.3V			0.4	
	$I_{OL} = 12 \text{ mA}$	$V_{IL} = 0.7\text{V}$	2.3V			0.7	
		$V_{IL} = 0.8\text{V}$	2.7V			0.4	
$I_{OL} = 24 \text{ mA}$	$V_{IL} = 0.8\text{V}$	3.0V			0.55		
$I_I$	$V_I = V_{CC}$ or GND		3.6V			$\pm 5$	$\mu\text{A}$
$I_I$ (Hold) <sup>(3)</sup>	$V_I = 0.7\text{V}$		2.3V	45			
	$V_I = 1.7\text{V}$			-45			
	$V_I = 0.8\text{V}$		3.0V	75			
	$V_I = 2.0\text{V}$			-75			
$V_I = 0$ to $3.6\text{V}$		3.6V			$\pm 500$		
$I_{OZ}^{(4)}$	$V_O = V_{CC}$ or GND		3.6V			$\pm 10$	$\mu\text{A}$
$I_{CC}$	$V_I = V_{CC}$ or GND	$I_O = 0$	3.6V			40	
$\Delta I_{CC}$	One input at $V_{CC} - 0.6\text{V}$ , Other inputs at $V_{CC}$ or GND		3V to 3.6V			750	
$C_I$ Control Inputs	$V_I = V_{CC}$ or GND		3.3V		4		pF
$C_{IO}$ A or B ports	$V_O = V_{CC}$ or GND		3.3V		8		

**Notes:**

1. For Max. or Min. conditions, use appropriate value specified under Electrical Characteristics for the applicable device type.
2. Typical values are at  $V_{CC} = 3.3\text{V}$ ,  $+25^\circ\text{C}$  ambient and maximum loading.
3. Bus Hold maximum dynamic current required to switch the input from one state to another.
4. For I/O ports, the  $I_{OZ}$  includes the input leakage current.

**Timing Requirements over Operating Range**

Parameters	Description	$V_{CC} = 2.5V \pm 0.2V$		$V_{CC} = 2.7V$		$V_{CC} = 3.3V \pm 0.3V$		Units
		Min.	Max.	Min.	Max.	Min.	Max.	
$f_{CLOCK}$	Clock frequency	0	140	0	150	0	150	MHz
$t_W$ Pulse Duration	LE high	3.3		3.3		3.3		ns
	CLK high or low	3.3		3.3		3.3		
$t_{SU}$ Setup time	Data before CLK high	2.3		2.4		2.1		
	Data before LE low, CLK high	2.0		1.6		1.6		
	Data before LE low, CLK low	1.3		1.2		1.1		
	CLKEN before CLK high	2.0		2.0		1.7		
$t_H$ Hold time	Data after CLK high	0.7		0.7		0.8		
	Data after LE low, CLK high	1.3		1.6		1.4		
	Data after LE low, CLK low	1.7		2.0		1.7		
	CLKEN after CLK high	0.3		0.5		0.6		
$\Delta t/\Delta v(1)$	Input Transition Rise or Fall	0	10	0	10	0	10	ns/V

**Note:**

1. Unused control inputs must be held HIGH or LOW to prevent them from floating.

**Switching Characteristics over Operating Range<sup>(1)</sup>**

Parameters	From(INPUT)	To(OUTPUT)	$V_{CC} = 2.5V \pm 0.2V$		$V_{CC} = 2.7V$		$V_{CC} = 3.3V \pm 0.3V$		Units
			Min. <sup>(2)</sup>	Max.	Min. <sup>(2)</sup>	Max.	Min. <sup>(2)</sup>	Max.	
$f_{MAX}$			140		150		150		MHz
$t_{PD}$	A	B	1.8	5.4		5.2	1.6	4.5	ns
$t_{PD}$	B	A	1.3	4.9		4.6	1	4.1	
$t_{PD}$	LEAB	B	1.5	6.1		5.9	1.5	5.1	
$t_{PD}$	LEBA	A	1.4	5.6		5.3	1	4.7	
$t_{PD}$	CLKAB	B	2	6.7		6.3	1.6	5.5	
$t_{PD}$	CLKBA	A	1.8	6.2		5.8	1.4	5	
$t_{EN}$	$\overline{OEAB}$	B	1.7	6.6		6.7	1.6	5.7	
$t_{DIS}$	$\overline{OEAB}$	B	2.5	5.9		5.3	1.8	4.8	
$t_{EN}$	$\overline{OEBA}$	A	1.2	6		6.1	1.1	5.2	
$t_{DIS}$	$\overline{OEBA}$	A	2.1	5.4		4.8	1.6	4.4	

**Notes:**

1. See test circuit and wave forms.
2. Minimum limits are guaranteed but not tested on Propagation Delays.

**Operating Characteristics,  $T_A = 25^\circ C$** 

Parameter		Test Conditions	$V_{CC} = 2.5V \pm 0.2V$	$V_{CC} = 3.3V \pm 0.3V$	Units
			Typical		
$C_{PD}$ Power Dissipation Capacitance	Outputs Enabled	$C_L = 50pF$ , $f = 10\text{ MHz}$	41	50	pF
	Outputs Disabled		6	6	