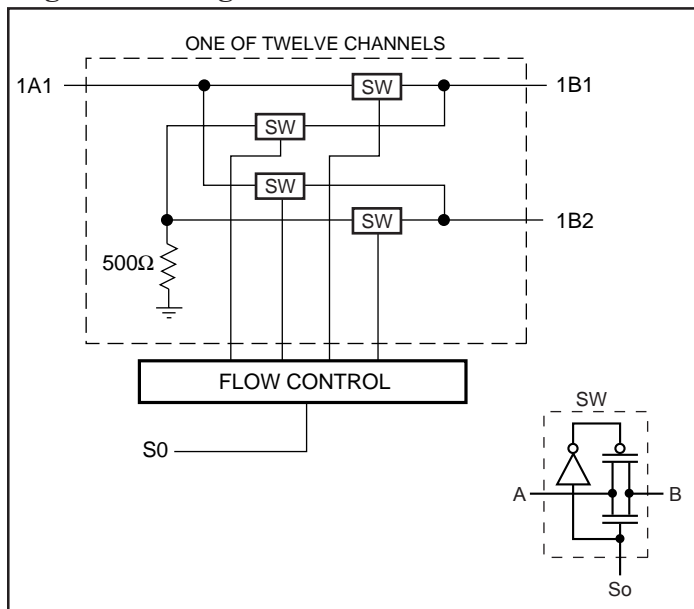

Features

- Near-zero propagation delay
- 5 ohm switches connect inputs to outputs
- Fast Switching Speed - 5ns (max.)
- Internal 500 ohm pull-down on A2 ports
- Ultra-low quiescent power (0.2µA typical)
– Ideally suited for notebook applications
- Vcc Operating Range : 3.0V to 3.6V
- Industrial operating temperature: -40°C to +85°C
- Make-before-break switching
- Packages available:
– 56-pin 240-mil wide thin plastic TSSOP (A)
– 56-pin 300-mil wide plastic SSOP (V)

Applications

- Memory switching

Logic Block Diagram

Product Pin Description

Pin Name	I/O	Description
S ₀	I	Select Inputs
xA1	I/O	Bus A
xBx	I/O	Bus B
NC		Leave it unconnected
NC1		Leave it unconnected

Description

Pericom Semiconductor's PI3B series of logic circuits are produced using the Company's advanced submicron CMOS technology.

The PI3B16292 is a 3.3 volt, 12-bit to 24-bit Mux/Demux Bus switches designed with a low On-resistance allowing inputs to be connected directly to outputs.

A2 port is not externally connected and, as a result, has an internal 500 ohm pulldown resistor to ground.

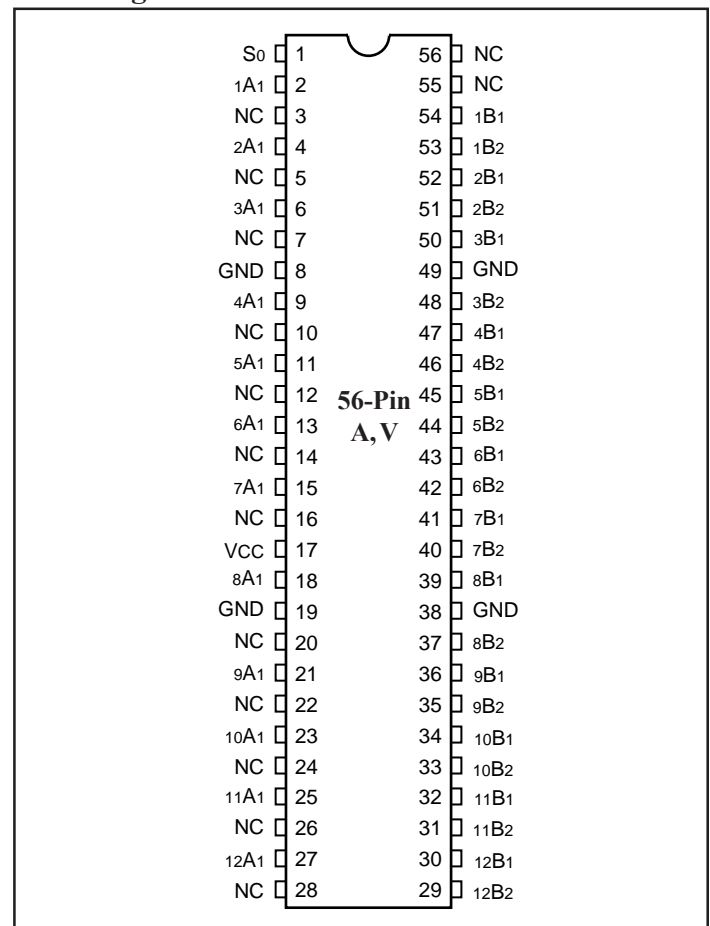
Pin Configuration

Truth Table

Function	S ₀	A ₁	A ₂
A ₁ to B ₁ , A ₂ to B ₂	L	B ₁	B ₂
A ₁ to B ₂ , A ₂ to B ₁	H	B ₂	B ₁

Note:

1. H = High Voltage Level; L = Low Voltage Level
Z = High Impedance

Maximum Ratings

(Above which useful life may be impaired. For user guidelines, not tested.)

Storage Temperature	-65°C to +150°C
Ambient Temperature with Power Applied	-0°C to +85°C
Supply Voltage Range	-0.5V to +4.6V
DC Input Voltage	-0.5V to +4.6V
DC Output Current	120mA
Power Dissipation	0.5Watt

Note:
Stresses greater than those listed under MAXIMUM RATINGS may cause permanent damage to the device. This is a stress rating only and functional operation of the device at these or any other conditions above those indicated in the operational sections of this specification is not implied. Exposure to absolute maximum rating conditions for extended periods may affect reliability.

DC Electrical Characteristics (Over the Operating Range, $T_A = -40^\circ\text{C}$ to $+85^\circ\text{C}$, $V_{CC} = 3.0\text{V}$ to 3.6V)

Parameters	Description	Test Conditions ⁽¹⁾	Min.	Typ. ⁽²⁾	Max.	Units
V_{IH}	Input HIGH Voltage	Guaranteed Logic HIGH Level	2.0	—	—	V
V_{IL}	Input LOW Voltage	Guaranteed Logic LOW Level	-0.5	—	0.8	
I_I	Input Current	$V_{CC} = \text{Max.}, V_{IN} = V_{CC}$ or GND	—	—	± 1	μA
		$V_{CC} = 0, V_{IN} = V_{CC}$	—	—	10	
V_{IK}	Clamp Diode Voltage	$V_{CC} = \text{Min.}, I_{IN} = -18\text{mA}$	—	-0.7	-1.2	V
R_{ON}	Switch ON Resistance ⁽³⁾	$V_{CC} = \text{Min.}, V_{IN} = 0.0\text{V}, I_{ON} = 64\text{mA}$	—	5	8	Ω
		$V_{CC} = \text{Min.}, V_{IN} = 2.4\text{V}, I_{ON} = 15\text{mA}$	—	10	15	

Capacitance ($T_A = 25^\circ\text{C}$, $f = 1\text{MHz}$)

Parameters ⁽⁴⁾	Description	Test Conditions	Typ.	Units
C_{IN}	Input Capacitance	$V_{IN} = 0\text{V}$	3.0	pF
C_{ON}	A/B Capacitance, Switch On		30.0	

Notes:

1. For Max. or Min. conditions, use appropriate value specified under Electrical Characteristics for the applicable device.
2. Typical values are at $V_{CC} = 3.3\text{V}$, $T_A = 25^\circ\text{C}$ ambient and maximum loading.
3. Measured by the voltage drop between A and B pin at indicated current through the switch. ON resistance is determined by the lower of the voltages on the two (A,B) pins.
4. This parameter is determined by device characterization but is not production tested.

Power Supply Characteristics

Parameters	Description	Test Conditions ⁽¹⁾		Min.	Type ⁽²⁾	Max.	Units
I_{CC}	Quiescent Power Supply Current	$V_{CC} = \text{Max.}$	$V_{IN} = \text{GND or } V_{CC}$	—	—	10	μA
$\Delta I_{CC}^{(3)}$	Supply Current for S0 @ TTL HIGH	$V_{CC} = \text{Max.}$	$V_{IN} = 3.0\text{V}^{(4)}$ Other Inputs @ V_{CC} or GND	—	—	750	
I_{CCD}	Supply Current for S0 per MHz ⁽⁵⁾ Toggling 50% Duty Cycle	$V_{CC} = \text{Max.},$ A and B Pins Open		—	—	0.25	mA/ MHz

Notes:

- For Max. or Min. conditions, use appropriate value specified under Electrical Characteristics for applicable device.
- Typical values are at $V_{CC} = 3.3\text{V}, +25^\circ\text{C}$ ambient.
- This is the increase in supply current for S0 at the specified TTL voltage level rather than V_{CC} or GND.
- Per driven input (S0 only); A and B pins do not contribute to I_{CC} .
- This current applies to the control inputs only and represent the current required to switch internal capacitance at the specified frequency. The A and B inputs generate no significant AC or DC currents as they transition. This parameter is not tested, but is guaranteed by design.

Switching Characteristics over Operating Range

Parameters	Description	Conditions ⁽¹⁾	Com.		Units
			Min.	Max.	
t_{PLH} t_{PHL}	Propagation Delay ^(2,3) xA1 to xBx, xBx to xA1	$C_L = 50\text{pF}$ $R_L = 500 \text{ ohms}$ $R = 500 \text{ ohms to } 6\text{V}^{(4)}$		0.25	ns
t_{PZH} t_{PZL}	Bus Enable Time S to A1 or xBx		1	4.5	
t_{PHZ} t_{PLZ}	Bus Disable Time S to A1 or xBx		1	5.0	
t_m	Make-before-break time ⁽²⁾		0	2	

Notes:

- See test circuit and waveforms.
- This parameter is guaranteed but not tested.
- The bus switch contributes no propagational delay other than the RC delay of the ON resistance of the switch and load capacitance. The time constant for the switch alone is of the order of 0.25ns for 50pF load. Since this time constant is much smaller than rise/fall times of typical driving signals, it adds very little propagational delay to the system. Propagational delay of the bus switch, when used in a system, is determined by the driving circuit on the driving side of the switch and its interaction with the load on the driven side.
- Applies to t_{PLZ} and t_{PZL} .

56-Pin SSOP (300 Mil Wide) (V) Package

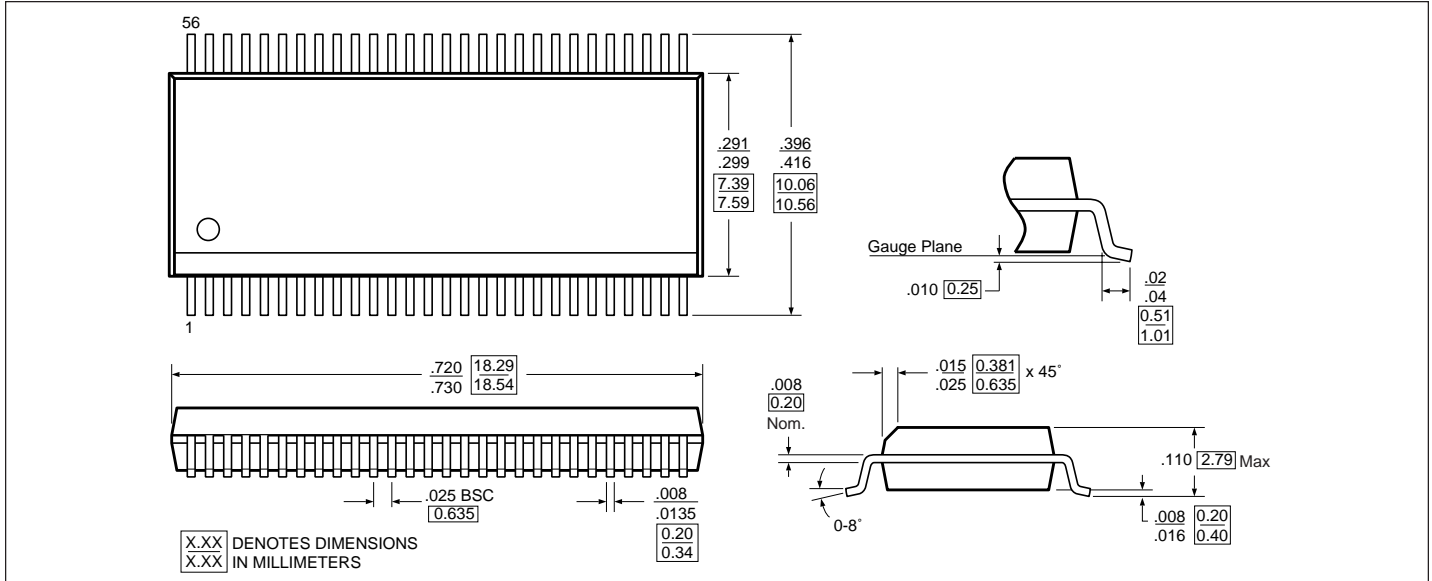

56-Pin TSSOP (240 Mil Wide) (A) Package

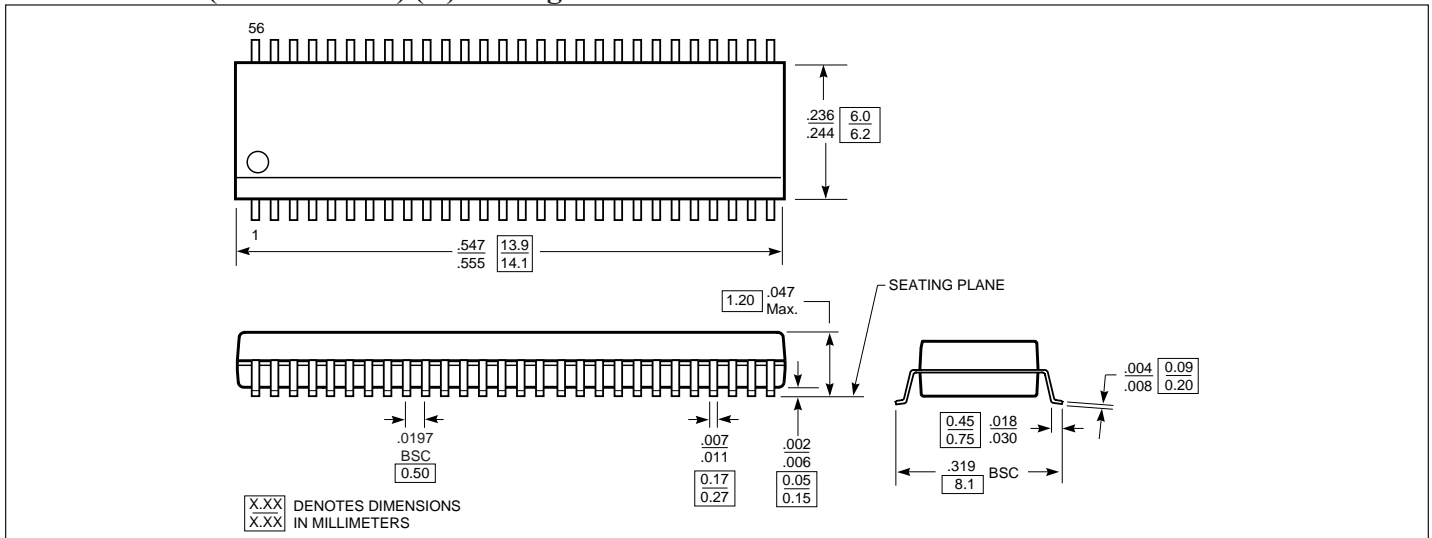

Ordering Information

Part	Pin - Package	Temperature
PI3B16292V	56-SSOP (V)	-40°C to +85°C
PI3B16292A	56-TSSOP (A)	

Applications Information

Logic Inputs

The logic control inputs can be driven up to +3.6V regardless of the supply voltage. For example, given a +3.3V supply, IN may be driven low to 0V and high to 3.6V. Driving IN Rail-to-Rail® minimizes power consumption.

Power-Supply Sequencing and Hot-Plug Information

Proper power-supply sequencing is recommended for all CMOS devices. Always apply V_{CC} and GND before applying signals to input/output or control pins.

Rail-to-Rail is a registered trademark of Nippon Motorola, Ltd.

Pericom Semiconductor Corporation

2380 Bering Drive • San Jose, CA 95131 • 1-800-435-2336 • Fax (408) 435-1100 • <http://www.pericom.com>