

---

## 2.4 GHz 256 QAM High-Power Amplifier

---

### Features

- High Gain:
  - Typically 33 dB gain across 2.4–2.5 GHz over temperature -40°C to +85°C
- High linear output power, typical performance:
  - 1.75% dynamic EVM up to 23 dBm, MCS8, 256 QAM, 40 MHz
  - 2.5% EVM up to 24 dBm, 802.11n, HT40
  - 3% EVM up to 25 dBm for 54 Mbps 802.11g signal
  - Meets 802.11g OFDM spectrum mask requirement up to 28.5 dBm
  - Meets 802.11b ACPR requirement up to 28.5 dBm
- High-speed power-up/down
  - Turn on/off time (10%-90%) <100 ns
- 10:1 VSWR survivability (unconditionally stable up to 28.5 dBm)
- On-chip power detection
  - 20 dB dynamic range
  - VSWR- and temperature-insensitive
- Simple input/output matching
- Packages available
  - 16-contact UQFN (3mm x 3mm)
- All non-Pb (lead-free) devices are RoHS compliant

### Applications

- WLAN (IEEE 802.11b/g/n)
- AP router
- WiMax (IEEE 802.16e)
- Home RF
- Cordless phones
- 2.4 GHz ISM wireless equipment
- 1.8-2.3 GHz femtocell base stations

### Product Description

SST12CP12 is a high-power, 256 QAM power amplifier (PA) based on the highly-reliable InGaP/GaAs HBT technology.

Operating over the 2.4–2.5 GHz frequency band, the PA will typically provide 33 dB gain with 25% power-added efficiency @  $P_{OUT} = 28$  dBm for 802.11g.

SST12CP12 has excellent linearity, providing less than 1.75%

dynamic EVM up to 23 dBm with MCS8, 40 MHz bandwidth modulation. It will also provide typically 3% added EVM at 25 dBm output power with 54 Mbps 802.11g operation while meeting 802.11g spectrum mask at 28.5 dBm. SST12CP12 also has a single-ended power detector for active power control.

The power amplifier IC also features high-speed power-up/-down control with the  $V_{REF}$  control pins.

SST12CP12 is offered in 16-contact UQFN package. See [Figure 2-1](#) for pin assignments and [Table 3-1](#) for pin descriptions.

## TO OUR VALUED CUSTOMERS

It is our intention to provide our valued customers with the best documentation possible to ensure successful use of your Microchip products. To this end, we will continue to improve our publications to better suit your needs. Our publications will be refined and enhanced as new volumes and updates are introduced.

If you have any questions or comments regarding this publication, please contact the Marketing Communications Department via E-mail at [docerrors@microchip.com](mailto:docerrors@microchip.com). We welcome your feedback.

### Most Current Data Sheet

To obtain the most up-to-date version of this data sheet, please register at our Worldwide Web site at:

<http://www.microchip.com>

You can determine the version of a data sheet by examining its literature number found on the bottom outside corner of any page. The last character of the literature number is the version number, (e.g., DS30000000A is version A of document DS30000000).

### Errata

An errata sheet, describing minor operational differences from the data sheet and recommended workarounds, may exist for current devices. As device/documentation issues become known to us, we will publish an errata sheet. The errata will specify the revision of silicon and revision of document to which it applies.

To determine if an errata sheet exists for a particular device, please check with one of the following:

- Microchip's Worldwide Web site; <http://www.microchip.com>
- Your local Microchip sales office (see last page)

When contacting a sales office, please specify which device, revision of silicon and data sheet (include literature number) you are using.

### Customer Notification System

Register on our web site at [www.microchip.com](http://www.microchip.com) to receive the most current information on all of our products.

1.0 FUNCTIONAL BLOCKS

FIGURE 1-1: FUNCTIONAL BLOCK DIAGRAM

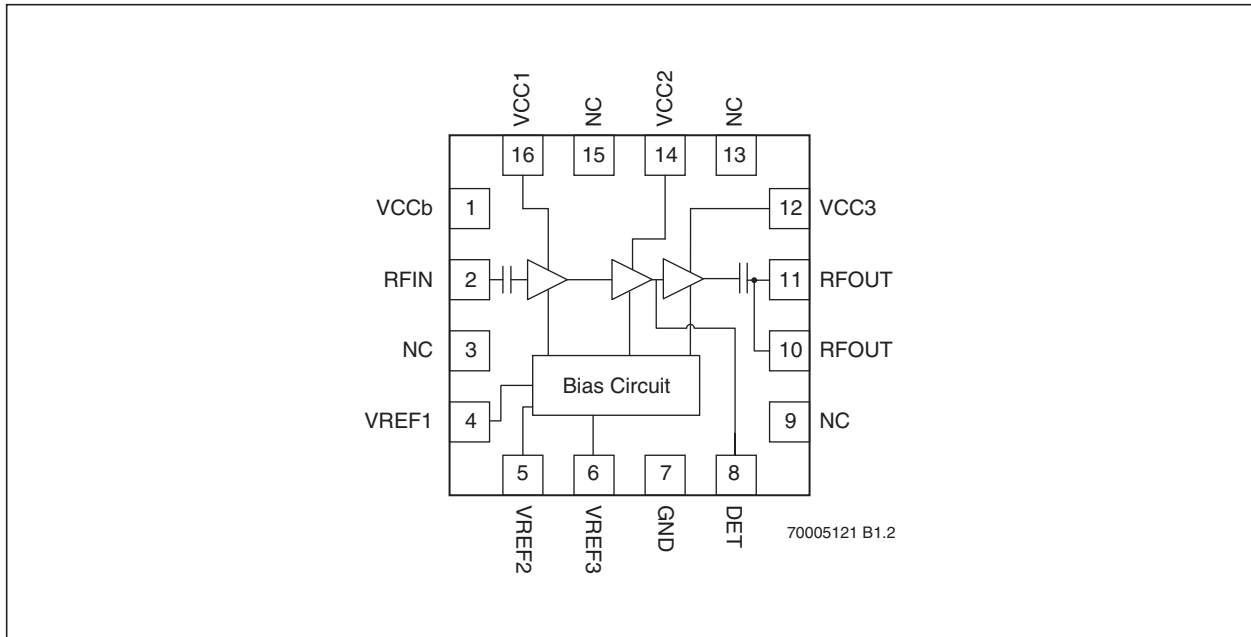

## 2.0 PIN ASSIGNMENTS

**FIGURE 2-1: PIN ASSIGNMENTS FOR 16-CONTACT UQFN**

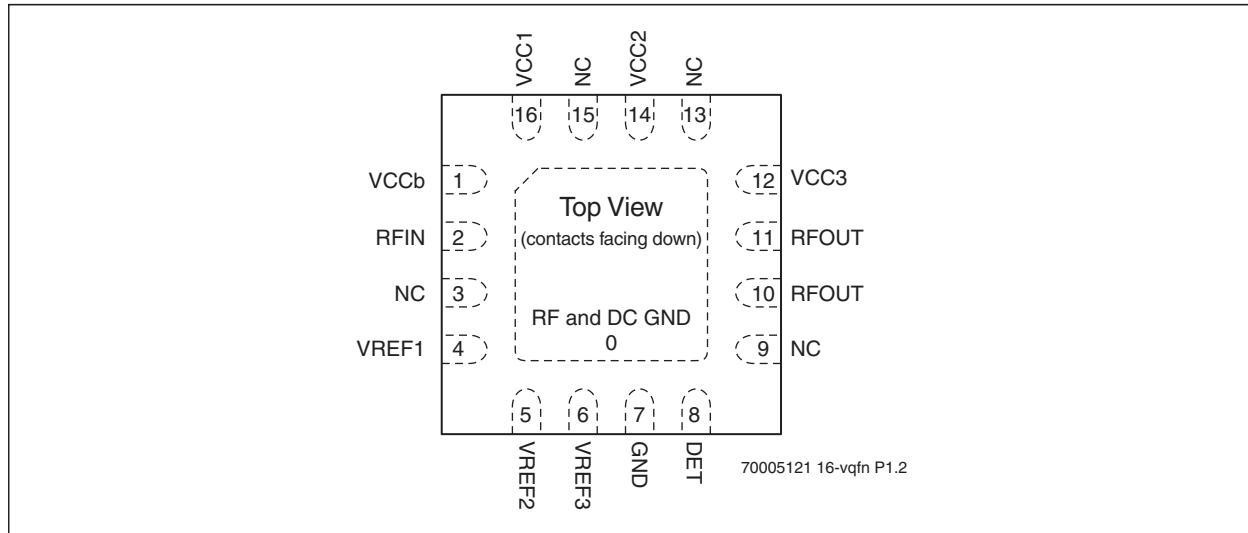

## 3.0 PIN DESCRIPTIONS

**TABLE 3-1: PIN DESCRIPTION**

Symbol	Pin No.	Pin Name	Type <sup>1</sup>	Function
GND	0	Ground		The center pad should be connected to RF ground with several low inductance, low resistance vias.
VCCb	1	Power Supply		Bias circuit supply
RFIN	2		I	RF input, DC decoupled
NC	3	No Connection		Unconnected, no internal connection
VREF1	4	Power Supply	PWR	1 <sup>st</sup> stage idle-current control
VREF2	5	Power Supply	PWR	2 <sup>nd</sup> stage idle-current control
VREF3	6	Power Supply	PWR	3rd stage idle-current control
GND	7	Ground		
Det	8		O	On-chip power detector
NC	9	No Connection		Unconnected, no internal connection
RFOUT	10		O	RF output
RFOUT	11		O	RF output
VCC3	12	Power Supply	PWR	Power supply, 3rd stage
NC	13	No Connection		Unconnected, no internal connection
VCC2	14	Power Supply	PWR	Power supply, 2nd stage
NC	15	No Connection		Unconnected pins.
VCC1	16	Power Supply	PWR	Power supply, 1st stage

1. I=Input, O=Output

## 4.0 ELECTRICAL SPECIFICATIONS

The AC and DC specifications for the power amplifier interface signals. Refer to Table 4-2 for the DC voltage and current specifications. Refer to Figures 5-1 through 6-5 for the RF performance.

**Absolute Maximum Stress Ratings** (Applied conditions greater than those listed under “Absolute Maximum Stress Ratings” may cause permanent damage to the device. This is a stress rating only and functional operation of the device at these conditions or conditions greater than those defined in the operational sections of this data sheet is not implied. Exposure to absolute maximum stress rating conditions may affect device reliability.)

Input power to pins 2 and 3 ( $P_{IN}$ )	5 dBm
Supply Voltage at pins 5, 12, 14, 16 ( $V_{CC}$ )	+6V
Reference voltage to pins 4 ( $V_{REF1}$ ) and pin 7 ( $V_{REF2}$ )	+3.5V
DC supply current ( $I_{CC}$ )	750 mA
Operating Temperature ( $T_A$ )	-40°C to +85°C
Storage Temperature ( $T_{STG}$ )	-40°C to +120°C
Maximum Junction Temperature ( $T_J$ )	+150°C
Surface Mount Solder Reflow Temperature	260°C for 10 seconds

**TABLE 4-1: OPERATING RANGE**

Range	Ambient Temp	$V_{CC}$
Industrial	-40°C to +85°C	3.0V to 5.0V

**TABLE 4-2: DC ELECTRICAL CHARACTERISTICS AT 25°C**

Symbol	Parameter	Min.	Typ	Max.	Unit
$V_{CC}$	Supply Voltage at pins 5, 12, 14, 16	4.0	5.0	5.5	V
$I_{CC}$	Average Current at 100% duty cycle				
	for 802.11g, 28.5 dBm		670		mA
	for 802.11b, 28.5 dBm		670		mA
	for 256 QAM, 27 dBm		600		mA
$I_{CQ}$	Idle current for 802.11g to meet EVM<3% @24.5 dBm, 100% duty cycle		375		mA
$V_{REG}$	Reference Supply	2.90	3.10	3.15	V

**TABLE 4-3: AC ELECTRICAL CHARACTERISTICS FOR CONFIGURATION AT 25°C**

Symbol	Parameter	Min.	Typ	Max.	Unit
F <sub>L-U</sub>	Frequency range in 802.11b/g and 256 QAM applications	2400		2500	MHz
P <sub>OUT</sub>	Output power at 3% EVM with 802.11g OFDM at 54 Mbps		25		dBm
	Output power at 1.75% dynamic EVM with MCS8, 40 MHz		23		dBm
	Output power meeting 802.11g spectral mask		28.5		dBm
	Output power meeting 256 QAM spectral mask		27		dBm
	Output power meeting 802.11b spectral mask		28.5		dBm
G	Power gain	32	33		dB
G <sub>VAR</sub>	Gain variation over 40 MHz			±0.5	dB
2f	Harmonics at 29 dBm, 802.11b mask compliance		-21		dBm/MHz
2f	Harmonics at 27 dBm		-38		dBm/MHz

## 5.0 TYPICAL PERFORMANCE CHARACTERISTICS

Test Conditions:  $V_{CC} = 5.0V$ ,  $V_{REG} = 3.1V$ ,  $T_A = 25^\circ C$  Unless otherwise specified

FIGURE 5-1: S-PARAMETERS

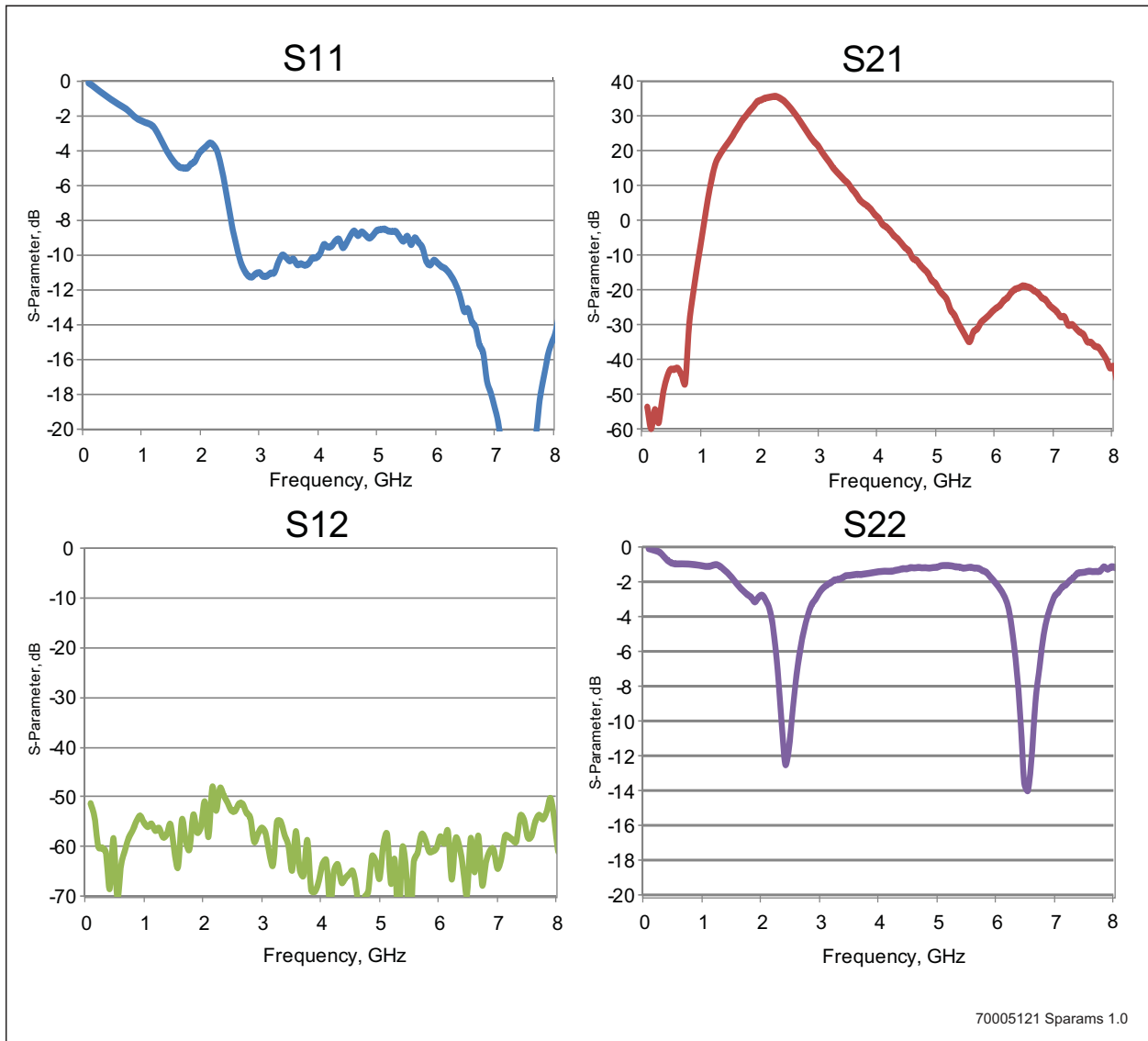

6.0 256 QAM APPLICATIONS

Typical Dynamic Performance Characteristics

Test Conditions:  $V_{CC} = 5.0V$ ,  $V_{REG} = 3.1 V$ ,  $T_A = 25^\circ C$ , MCS8 40 MHz signal, data duty cycle 23% (60  $\mu s$  on /200  $\mu s$  idle) unless otherwise specified

FIGURE 6-1: EVM VERSUS OUTPUT POWER, 100% DUTY CYCLE

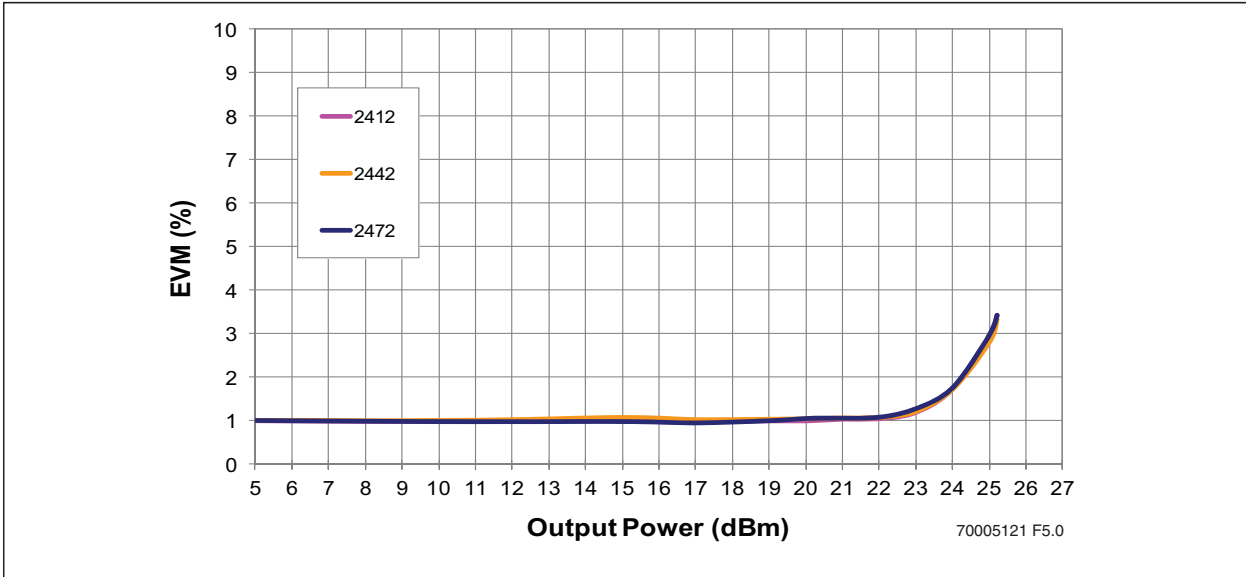
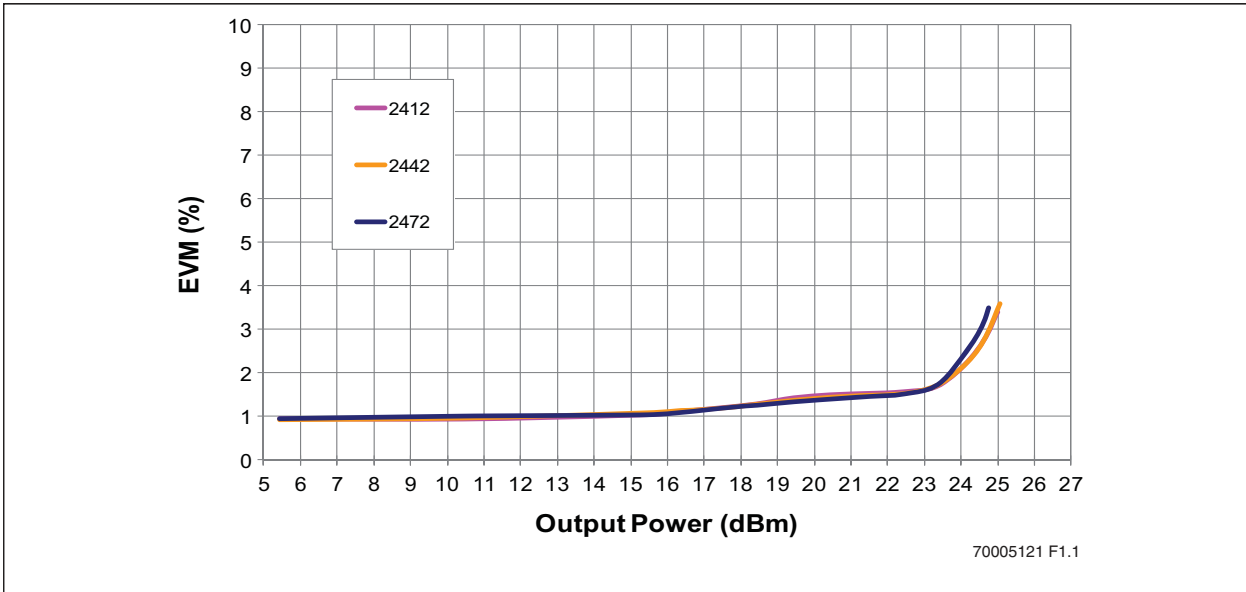

FIGURE 6-2: DYNAMIC EVM VERSUS OUTPUT POWER, 23% DUTY CYCLE





256 QAM APPLICATIONS (CONTINUED)

FIGURE 6-3: POWER GAIN VERSUS OUTPUT POWER

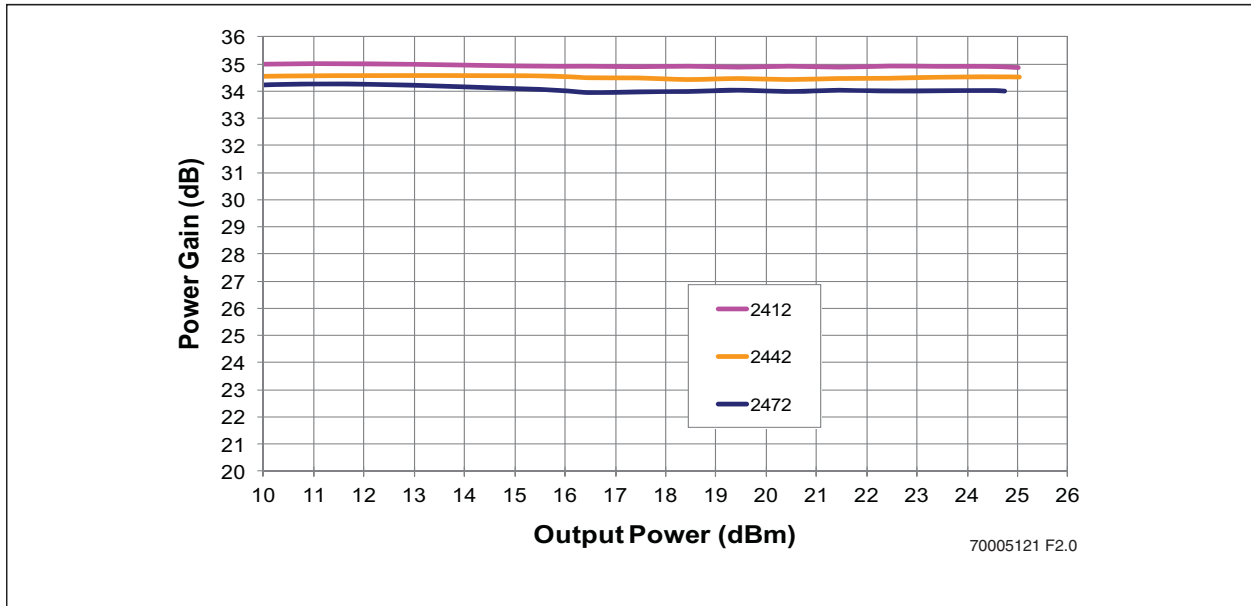
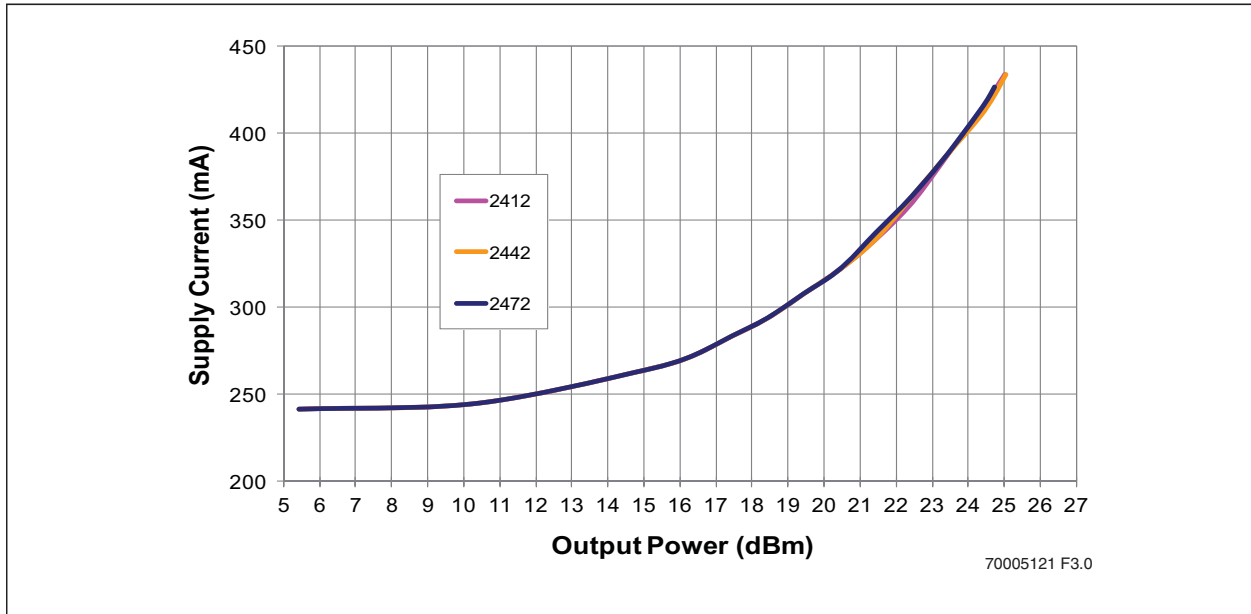

FIGURE 6-4: INSTANTANEOUS SUPPLY CURRENT VERSUS OUTPUT POWER FOR DYNAMIC OPERATION, 23% DUTY CYCLE



256 QAM APPLICATIONS (CONTINUED)

FIGURE 6-5: INSTANTANEOUS DETECTOR VOLTAGE VERSUS OUTPUT POWER

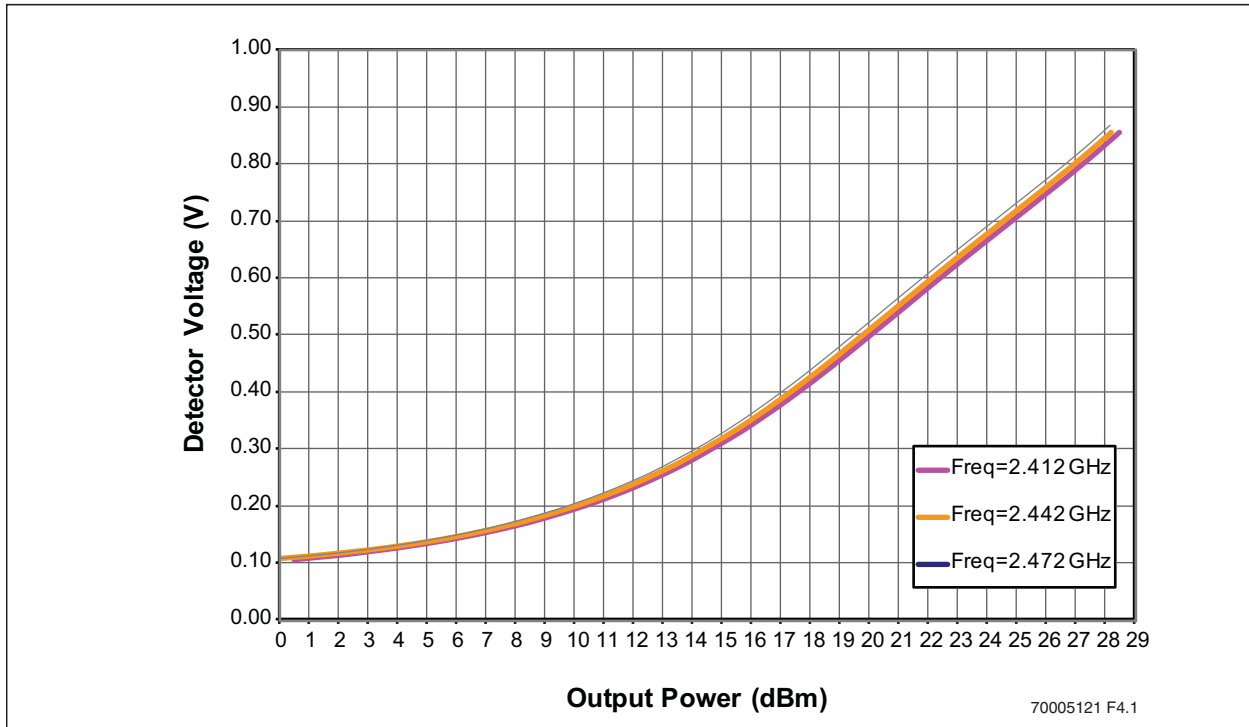
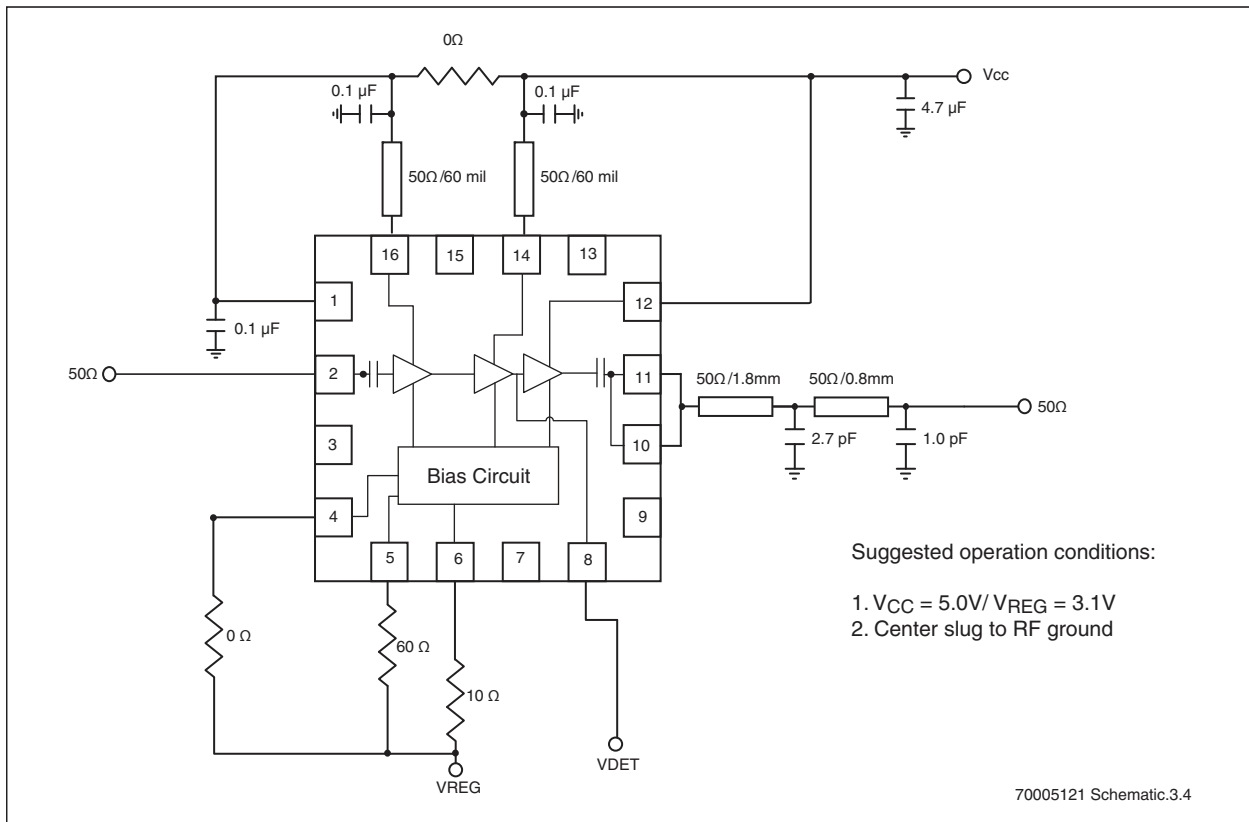
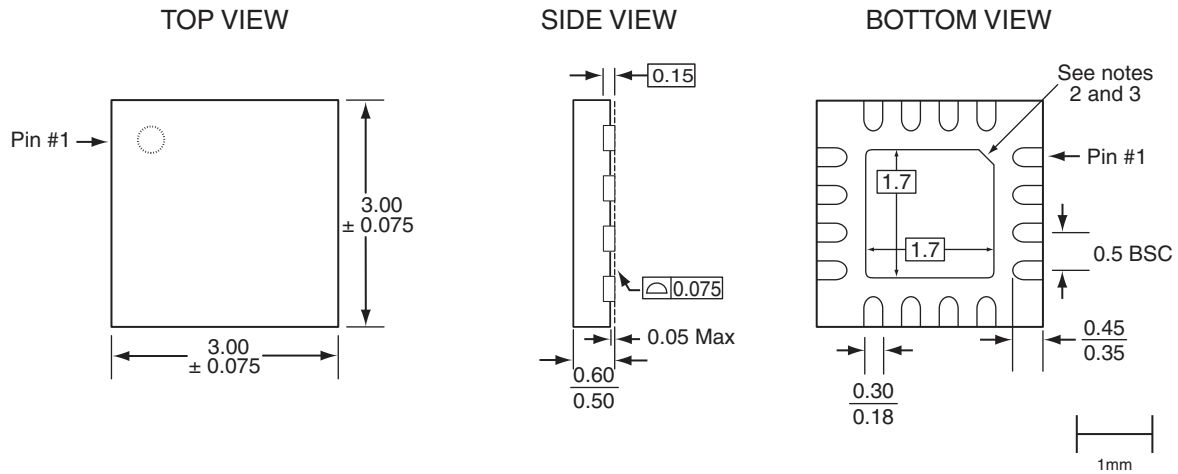

FIGURE 6-6: TYPICAL SCHEMATIC FOR 256 QAM APPLICATIONS



7.0 PACKAGE INFORMATION

FIGURE 7-1: 16-CONTACT ULTRA-THIN QUAD FLAT NO-LEAD (UQFN)  
PACKAGE CODE: QUC



- Note: 1. Complies with JEDEC JEP95 MO-248D, variant UEED-4 except external paddle nominal dimensions.  
 2. From the bottom view, the pin #1 indicator may be either a 45-degree chamfer or a half-circle notch.  
 3. The external paddle is electrically connected to the die back-side and possibly to certain V<sub>SS</sub> leads. This paddle can be soldered to the PC board; it is suggested to connect this paddle to the V<sub>SS</sub> of the unit. Connection of this paddle to any other voltage potential can result in shorts and/or electrical malfunction of the device.  
 4. Untoleranced dimensions are nominal target dimensions.  
 5. All linear dimensions are in millimeters (max/min).

16-uqfn-3x3-QUC-0.0

TABLE 7-1: REVISION HISTORY

Revision	Description	Date
A	• Initial release of data sheet	Apr 2013
B	• Updated <a href="#">Table 4-2 on page 5</a> • Revised <a href="#">Figure 6-5 on page 10</a>	Sep 2013

## THE MICROCHIP WEB SITE

Microchip provides online support via our WWW site at [www.microchip.com](http://www.microchip.com). This web site is used as a means to make files and information easily available to customers. Accessible by using your favorite Internet browser, the web site contains the following information:

- **Product Support** – Data sheets and errata, application notes and sample programs, design resources, user's guides and hardware support documents, latest software releases and archived software
- **General Technical Support** – Frequently Asked Questions (FAQs), technical support requests, online discussion groups, Microchip consultant program member listing
- **Business of Microchip** – Product selector and ordering guides, latest Microchip press releases, listing of seminars and events, listings of Microchip sales offices, distributors and factory representatives

## CUSTOMER CHANGE NOTIFICATION SERVICE

Microchip's customer notification service helps keep customers current on Microchip products. Subscribers will receive e-mail notification whenever there are changes, updates, revisions or errata related to a specified product family or development tool of interest.

To register, access the Microchip web site at [www.microchip.com](http://www.microchip.com). Under "Support", click on "Customer Change Notification" and follow the registration instructions.

## CUSTOMER SUPPORT

Users of Microchip products can receive assistance through several channels:

- Distributor or Representative
- Local Sales Office
- Field Application Engineer (FAE)
- Technical Support

Customers should contact their distributor, representative or field application engineer (FAE) for support. Local sales offices are also available to help customers. A listing of sales offices and locations is included in the back of this document.

**Technical support is available through the web site at: <http://microchip.com/support>**

## 8.0 PRODUCT IDENTIFICATION SYSTEM

To order or obtain information, e.g., on pricing or delivery, refer to the factory or the listed sales office.

<u>PART NO.</u>		<u>XXX</u>
Device		Package
Device:	SST12CP12	= 2.4 GHz High-power and High-gain Power Amplifier
Package:	QUCE	= UQFN (3mm x 3mm), 0.6 max thickness 16-contact
Evaluation Kit Flag	K	= Evaluation Kit

**Valid Combinations:**  
 SST12CP12-QUCE  
 SST12CP12-QUCE-K

---

**Note the following details of the code protection feature on Microchip devices:**

- Microchip products meet the specification contained in their particular Microchip Data Sheet.
- Microchip believes that its family of products is one of the most secure families of its kind on the market today, when used in the intended manner and under normal conditions.
- There are dishonest and possibly illegal methods used to breach the code protection feature. All of these methods, to our knowledge, require using the Microchip products in a manner outside the operating specifications contained in Microchip's Data Sheets. Most likely, the person doing so is engaged in theft of intellectual property.
- Microchip is willing to work with the customer who is concerned about the integrity of their code.
- Neither Microchip nor any other semiconductor manufacturer can guarantee the security of their code. Code protection does not mean that we are guaranteeing the product as “unbreakable.”

Code protection is constantly evolving. We at Microchip are committed to continuously improving the code protection features of our products. Attempts to break Microchip's code protection feature may be a violation of the Digital Millennium Copyright Act. If such acts allow unauthorized access to your software or other copyrighted work, you may have a right to sue for relief under that Act.

---

Information contained in this publication regarding device applications and the like is provided only for your convenience and may be superseded by updates. It is your responsibility to ensure that your application meets with your specifications. MICROCHIP MAKES NO REPRESENTATIONS OR WARRANTIES OF ANY KIND WHETHER EXPRESS OR IMPLIED, WRITTEN OR ORAL, STATUTORY OR OTHERWISE, RELATED TO THE INFORMATION, INCLUDING BUT NOT LIMITED TO ITS CONDITION, QUALITY, PERFORMANCE, MERCHANTABILITY OR FITNESS FOR PURPOSE. Microchip disclaims all liability arising from this information and its use. Use of Microchip devices in life support and/or safety applications is entirely at the buyer's risk, and the buyer agrees to defend, indemnify and hold harmless Microchip from any and all damages, claims, suits, or expenses resulting from such use. No licenses are conveyed, implicitly or otherwise, under any Microchip intellectual property rights.

#### **Trademarks**

The Microchip name and logo, the Microchip logo, dsPIC, FlashFlex, KEELOQ, KEELOQ logo, MPLAB, PIC, PICmicro, PICSTART, PIC<sup>32</sup> logo, rPIC, SST, SST Logo, SuperFlash and UNI/O are registered trademarks of Microchip Technology Incorporated in the U.S.A. and other countries.

FilterLab, Hampshire, HI-TECH C, Linear Active Thermistor, MTP, SEEVAL and The Embedded Control Solutions Company are registered trademarks of Microchip Technology Incorporated in the U.S.A.

Silicon Storage Technology is a registered trademark of Microchip Technology Inc. in other countries.

Analog-for-the-Digital Age, Application Maestro, BodyCom, chipKIT, chipKIT logo, CodeGuard, dsPICDEM, dsPICDEM.net, dsPICworks, dsSPEAK, ECAN, ECONOMONITOR, FanSense, HI-TIDE, In-Circuit Serial Programming, ICSP, Mindi, MiWi, MPASM, MPF, MPLAB Certified logo, MPLIB, MPLINK, mTouch, Omniscient Code Generation, PICC, PICC-18, PICDEM, PICDEM.net, PICkit, PICtail, REAL ICE, rLAB, Select Mode, SQI, Serial Quad I/O, Total Endurance, TSHARC, UniWinDriver, WiperLock, ZENA and Z-Scale are trademarks of Microchip Technology Incorporated in the U.S.A. and other countries.

SQTP is a service mark of Microchip Technology Incorporated in the U.S.A.

GestIC and ULPP are registered trademarks of Microchip Technology Germany II GmbH & Co. & KG, a subsidiary of Microchip Technology Inc., in other countries.

All other trademarks mentioned herein are property of their respective companies.

© 2013, Microchip Technology Incorporated, Printed in the U.S.A., All Rights Reserved.

 Printed on recycled paper.

ISBN: 978-1-62077-425-0

*Microchip received ISO/TS-16949:2009 certification for its worldwide headquarters, design and wafer fabrication facilities in Chandler and Tempe, Arizona; Gresham, Oregon and design centers in California and India. The Company's quality system processes and procedures are for its PIC® MCUs and dsPIC® DSCs, KEELOQ® code hopping devices, Serial EEPROMs, microperipherals, nonvolatile memory and analog products. In addition, Microchip's quality system for the design and manufacture of development systems is ISO 9001:2000 certified.*

---

**QUALITY MANAGEMENT SYSTEM  
CERTIFIED BY DNV  
= ISO/TS 16949 =**



---

---

## World Wide Sales and Service

---

---

### AMERICAS

**Corporate Office**  
2355 West Chandler Blvd.  
Chandler, AZ 85224-6199  
Tel: 480-792-7200  
Fax: 480-792-7277  
Technical Support:  
<http://www.microchip.com/support>  
Web Address:  
[www.microchip.com](http://www.microchip.com)

#### Atlanta

Duluth, GA  
Tel: 678-957-9614  
Fax: 678-957-1455

#### Boston

Westborough, MA  
Tel: 774-760-0087  
Fax: 774-760-0088

#### Chicago

Itasca, IL  
Tel: 630-285-0071  
Fax: 630-285-0075

#### Cleveland

Independence, OH  
Tel: 216-447-0464  
Fax: 216-447-0643

#### Dallas

Addison, TX  
Tel: 972-818-7423  
Fax: 972-818-2924

#### Detroit

Farmington Hills, MI  
Tel: 248-538-2250  
Fax: 248-538-2260

#### Indianapolis

Noblesville, IN  
Tel: 317-773-8323  
Fax: 317-773-5453

#### Los Angeles

Mission Viejo, CA  
Tel: 949-462-9523  
Fax: 949-462-9608

#### Santa Clara

Santa Clara, CA  
Tel: 408-961-6444  
Fax: 408-961-6445

#### Toronto

Mississauga, Ontario,  
Canada  
Tel: 905-673-0699  
Fax: 905-673-6509

### ASIA/PACIFIC

**Asia Pacific Office**  
Suites 3707-14, 37th Floor  
Tower 6, The Gateway  
Harbour City, Kowloon  
Hong Kong  
Tel: 852-2401-1200  
Fax: 852-2401-3431

#### Australia - Sydney

Tel: 61-2-9868-6733  
Fax: 61-2-9868-6755

#### China - Beijing

Tel: 86-10-8569-7000  
Fax: 86-10-8528-2104

#### China - Chengdu

Tel: 86-28-8665-5511  
Fax: 86-28-8665-7889

#### China - Chongqing

Tel: 86-23-8980-9588  
Fax: 86-23-8980-9500

#### China - Hangzhou

Tel: 86-571-2819-3187  
Fax: 86-571-2819-3189

#### China - Hong Kong SAR

Tel: 852-2401-1200  
Fax: 852-2401-3431

#### China - Nanjing

Tel: 86-25-8473-2460  
Fax: 86-25-8473-2470

#### China - Qingdao

Tel: 86-532-8502-7355  
Fax: 86-532-8502-7205

#### China - Shanghai

Tel: 86-21-5407-5533  
Fax: 86-21-5407-5066

#### China - Shenyang

Tel: 86-24-2334-2829  
Fax: 86-24-2334-2393

#### China - Shenzhen

Tel: 86-755-8203-2660  
Fax: 86-755-8203-1760

#### China - Wuhan

Tel: 86-27-5980-5300  
Fax: 86-27-5980-5118

#### China - Xian

Tel: 86-29-8833-7252  
Fax: 86-29-8833-7256

#### China - Xiamen

Tel: 86-592-2388138  
Fax: 86-592-2388130

#### China - Zhuhai

Tel: 86-756-3210040  
Fax: 86-756-3210049

### ASIA/PACIFIC

**India - Bangalore**  
Tel: 91-80-3090-4444  
Fax: 91-80-3090-4123

#### India - New Delhi

Tel: 91-11-4160-8631  
Fax: 91-11-4160-8632

#### India - Pune

Tel: 91-20-2566-1512  
Fax: 91-20-2566-1513

#### Japan - Osaka

Tel: 81-66-152-7160  
Fax: 81-66-152-9310

#### Japan - Yokohama

Tel: 81-45-471- 6166  
Fax: 81-45-471-6122

#### Korea - Daegu

Tel: 82-53-744-4301  
Fax: 82-53-744-4302

#### Korea - Seoul

Tel: 82-2-554-7200  
Fax: 82-2-558-5932 or  
82-2-558-5934

#### Malaysia - Kuala Lumpur

Tel: 60-3-6201-9857  
Fax: 60-3-6201-9859

#### Malaysia - Penang

Tel: 60-4-227-8870  
Fax: 60-4-227-4068

#### Philippines - Manila

Tel: 63-2-634-9065  
Fax: 63-2-634-9069

#### Singapore

Tel: 65-6334-8870  
Fax: 65-6334-8850

#### Taiwan - Hsin Chu

Tel: 886-3-5778-366  
Fax: 886-3-5770-955

#### Taiwan - Kaohsiung

Tel: 886-7-536-4818  
Fax: 886-7-330-9305

#### Taiwan - Taipei

Tel: 886-2-2500-6610  
Fax: 886-2-2508-0102

#### Thailand - Bangkok

Tel: 66-2-694-1351  
Fax: 66-2-694-1350

### EUROPE

#### Austria - Wels

Tel: 43-7242-2244-39  
Fax: 43-7242-2244-393

#### Denmark - Copenhagen

Tel: 45-4450-2828  
Fax: 45-4485-2829

#### France - Paris

Tel: 33-1-69-53-63-20  
Fax: 33-1-69-30-90-79

#### Germany - Munich

Tel: 49-89-627-144-0  
Fax: 49-89-627-144-44

#### Italy - Milan

Tel: 39-0331-742611  
Fax: 39-0331-466781

#### Netherlands - Drunen

Tel: 31-416-690399  
Fax: 31-416-690340

#### Spain - Madrid

Tel: 34-91-708-08-90  
Fax: 34-91-708-08-91

#### UK - Wokingham

Tel: 44-118-921-5869  
Fax: 44-118-921-5820