

PRODUCT NUMBER

10142959-0XXLF

NOTES:

1. MATERIAL: 0.20mm THICK COPPER ALLOY
2. FINISH:
30U" NICKEL UNDER PLATING
80U" TIN ON SOLDER TAIL
3. APPLICABLE WIRES: AWG#20-#28
4. INSULATION O.D.: 1.3~1.7mm
5. RoHS COMPLIANT
6. THIS TERMINAL IS USED WITH FCI HSG: 10142958
7. PRODUCT SPEC: GS-12-1408.
8. PACKING SPEC: GS-14-2573.
6. PART NUMBER SCHEME:
10142959- 0 X X LF

FINISH:

- 1: PRE-MATTE TIN PLATED
- 2: POST-MATTE TIN PLATED
- 3: PRE-BRIGHT TIN PLATED
- 4: POST-BRIGHT TIN PLATED
- 5: GOLD PLATED

Material:

- 1: BRASS
- 2: PHOSPHOR BRONZE

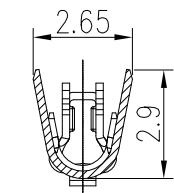
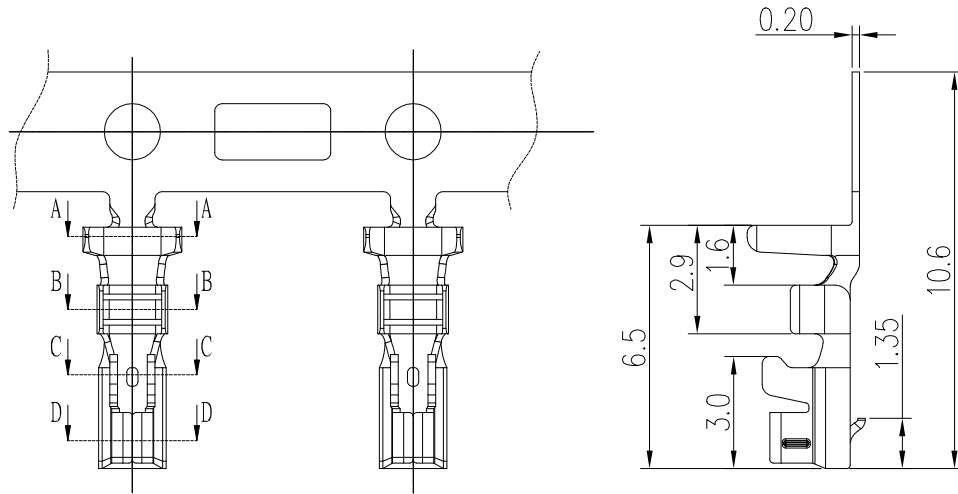

SECTION A-A

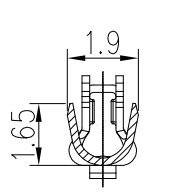

SECTION B-B

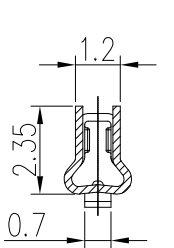

SECTION C-C

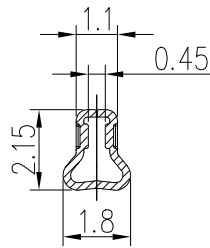

SECTION D-D

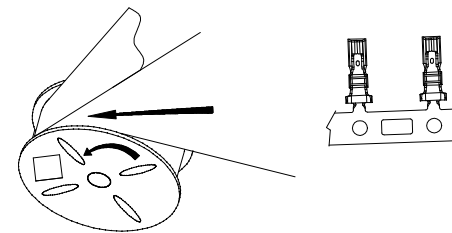

RAW INTO DIRECTION

mat'l. code		surface <input checked="" type="checkbox"/> tolerance		projection		product family	
ltr		ecn no dr date		tolerances unless otherwise specified		WTB	
A		TONY 2017-03-01		angles		title	
				linear		2.5mm Pitch Crimp Terminal	
				°±5'		scale N.T.S.	
		dr TONY_LENG 2017-03-01				dwg no sheet 1 of 1 size	
		enr TONY_LENG 2017-03-01				10142959 A4	
		chr ZK_HU 2017-03-01				type Product Customer Drawing	
		appd TIM_YAO 2017-03-01					
sheet index		revision sheet		A 1			