

THIS DRAWING IS UNPUBLISHED. RELEASED FOR PUBLICATION
 © COPYRIGHT BY TYCO ELECTRONICS CORPORATION. ALL RIGHTS RESERVED.

LOC	DIST	REVISIONS			
P	LTR	DESCRIPTION	DATE	DWN	APVD
AF	50	A1	REL PER ECR 05-014808	04NOV05	JR KR

- CONTINUOUS STRIP ON REELS
- WIRE RANGE IS 400-1360 CMA
 .070 CRIMP WIDTH, F AMPLIVAR TYPE
 CRIMP HEIGHT (+/- .002) = (TOTAL CMA + 5400) / 121,500.

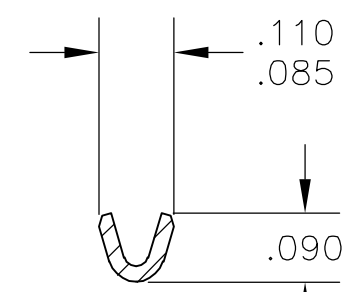
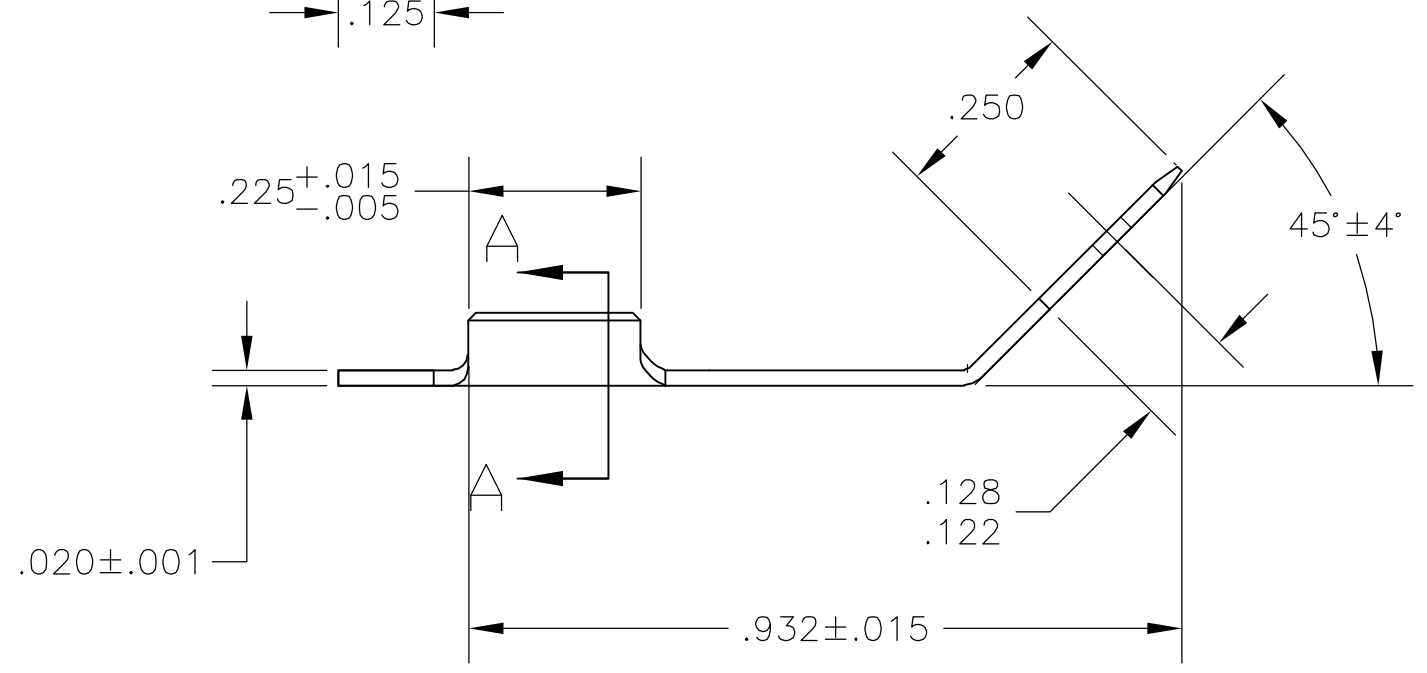
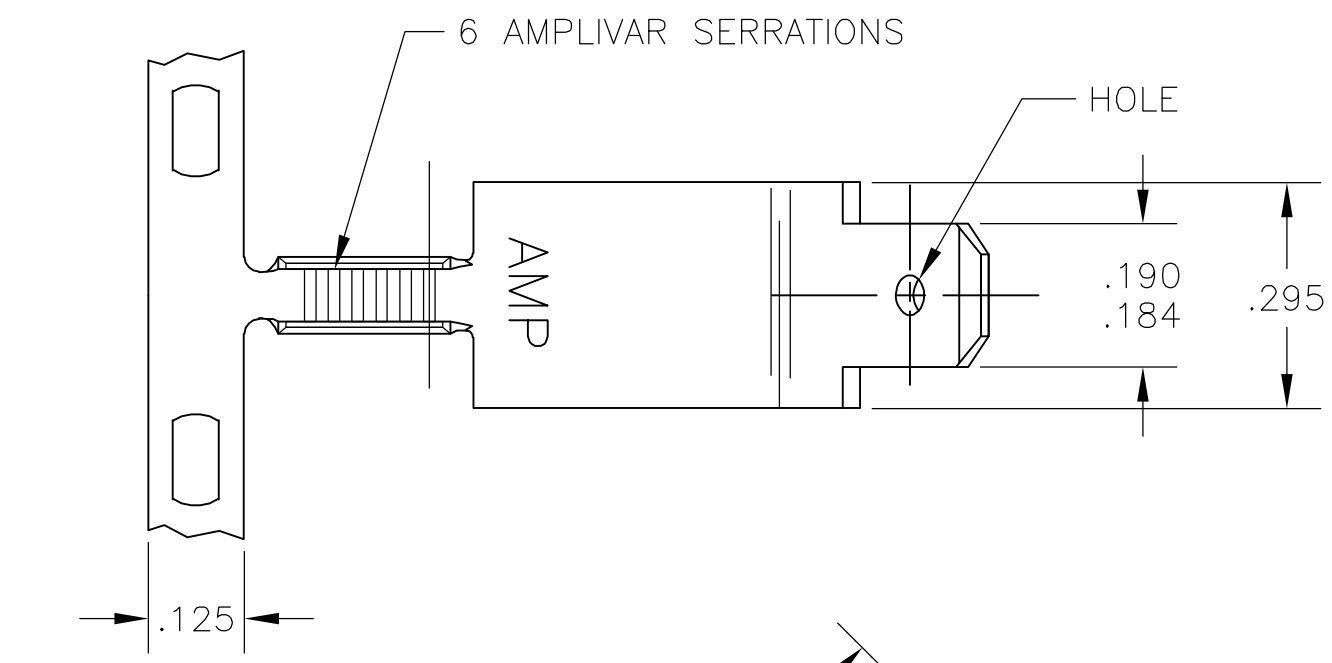

1742262-1
 PART NO

THIS DRAWING IS A CONTROLLED DOCUMENT.		DWN jr ruth 04APR05	Tyco Electronics Corporation Harrisburg, PA 17105-3608		
DIMENSIONS: INCHES		CHK K RANDOLPH 04APR05			
TOLERANCES UNLESS OTHERWISE SPECIFIED:		APVD K RANDOLPH 04APR05	NAME TAB, FASTON, AMPLIVAR, .187 SERIES		
0 PLC ± - 1 PLC ± - 2 PLC ± - 3 PLC ± .010 4 PLC ± - ANGLES ± 5°		PRODUCT SPEC -	APPLICATION SPEC -		
MATERIAL 082 BRASS		FINISH .000080 MIN TIN	SIZE A3	CAGE CODE 00779	DRAWING NO 1742262
CUSTOMER DRAWING			RESTRICTED TO -	SCALE 1:1	SHEET 1 of 1
			REV A1		