

To be read in conjunction with "Introduction to Pellistor Gas Sensors" and Pellistor Application Notes 1, 2, 3, 4, 6 and 7.

## INTRODUCTION

The VQ2 consists of two matched elements which are used for the detection of combustible gases, particularly methane in air mixtures in concentrations from 0.1% upwards. There is no interference from water vapour or carbon dioxide. Using the recommended bridge circuit (see below) and the mounting arrangement shown on page 2, the minimum sensitivity is 15 mV/% methane.

The low power consumption of the VQ2 makes it suitable for use where the power consumption must be minimised, e.g. battery operated systems.

## GENERAL DATA

### Electrical

The information given below relates to the VQ2 operating in the recommended circuit shown.

Operation (see note 1)	continuous
Bridge supply	2.0 ± 0.1 V
Bridge power consumption (at 2.0 V)	0.48 W max
Minimum sensitivity (see note 2)	15 mV/% methane
Linearity	linear up to 3% methane
Response time to register 1 <sup>1</sup> / <sub>4</sub> % in a 2 <sup>1</sup> / <sub>2</sub> % concentration (see notes 2 and 3)	2 seconds
Maximum methane concentration (see note 4)	5 %

### Mechanical

Mounting	see page 2
Outline	see page 2
Shock test	250 g, 5 blows in each plane
Vibration test	20 g, 24 cycles from 100 to 3200 Hz
Ambient temperature range (see note 7)	-5 to +40 °C

## BRIDGE CIRCUIT

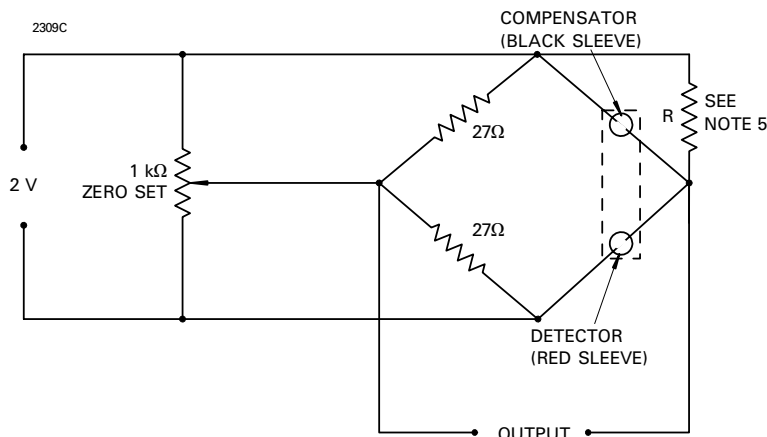

## MARKING

Each element is identified by a unique serial number written on the can of both the detector and compensator. The serial number is written in red on the detector and black on the compensator. In addition, the detector carries a red circular label on the base identifying the device type.

## NOTES

1. Operation may be under either direct flow or diffusion conditions in appropriate mountings (see page 2).
2. With open-circuit conditions at the bridge output.
3. The response time is a function of the type of mounting used.
4. If the VQ2 is exposed to greater than 5% methane concentration, the calibration of the instrument should be checked.
5. The elements are supplied as a matched pair with a trimming resistor R of the correct value which is between 68 and 220 Ω. The trimming resistor is to be connected across the compensator element as shown below.
6. The elements must be protected from certain organic and silicone vapours by suitable filtering, and caution should be exercised when operating in close proximity to hot, oily machinery.
7. The bridge zero shall not change by more than 1.5 mV for this temperature range.

# OUTLINE (All dimensions without limits are nominal)

2311B

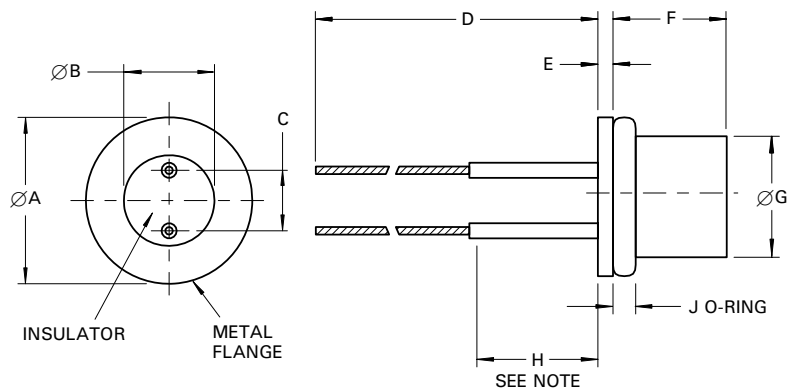

Ref	Millimetres
A	$11.05 \pm 0.25$
B	$6.10 \pm 0.25$
C	$3.56 \pm 0.13$
D	63.5 min
E	1.02
F	$7.37 \pm 0.51$
G	8.20 max
H	9.53
J	1.52

**Note** No bends may be made in this length.

# RECOMMENDED MOUNTING ARRANGEMENTS

2310C

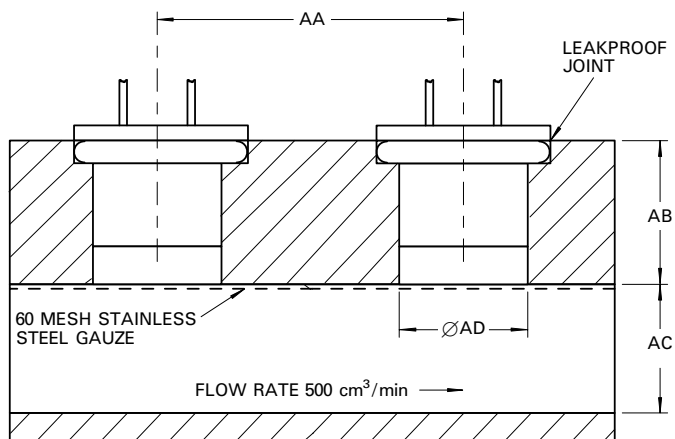

Ref	Millimetres
AA	19.05 max
AB	$9.53 \pm 0.13$
AC	$8.33 \pm 0.13$
AD	8.20 min
AE	19.05 max
AF	$9.53 \pm 0.13$
AG	8.20 min

