

Evaluating the **AD5144** Digital Potentiometer

FEATURES

- Full featured evaluation board in conjunction with low voltage digiPOT motherboard (EVAL-MB-LV-SDZ)
- Various test circuits
- Various ac/dc input signals
- PC control via a separately purchased system demonstration platform (SDP-B or SDP-S)
- PC software for control

PACKAGE CONTENTS

- EVAL-AD5144DBZ board
- EVAL-MB-LV-SDZ motherboard
- CD that includes

- Self-installing software that allows users to control the board and exercise all functions of the device
- Electronic version of the **AD5144** data sheet
- Electronic version of the **UG-469** user guide

GENERAL DESCRIPTION

This user guide describes the evaluation board for evaluating the **AD5144**—a quad-channel, 256-position, nonvolatile memory, digital potentiometer. With versatile programmability, the **AD5144** allows multiple modes of operation, including read/write access in the RDAC and EEMEM registers, increment/decrement of resistance, resistance changes in ± 6 dB scales, wiper setting read-back, and extra EEMEM for storing user-defined information, such as memory data for other components or a lookup table.

The **AD5144** supports a dual-supply ± 2.25 V to ± 2.75 V operation and a single-supply 2.3 V to 5.5 V operation, making the device suitable for battery-powered applications and many other applications. In addition, the **AD5144** can be configured as a versatile I²C or SPI serial interface. The **EVAL-AD5144DBZ** can operate in single-supply or dual-supply mode and incorporates an internal power supply from the USB.

Complete specifications for the **AD5144** part can be found in the **AD5144** data sheet, which is available from Analog Devices, Inc., and should be consulted in conjunction with this user guide when using the evaluation board.

EVAL-AD5144DBZ WITH MOTHERBOARD AND SDP-S

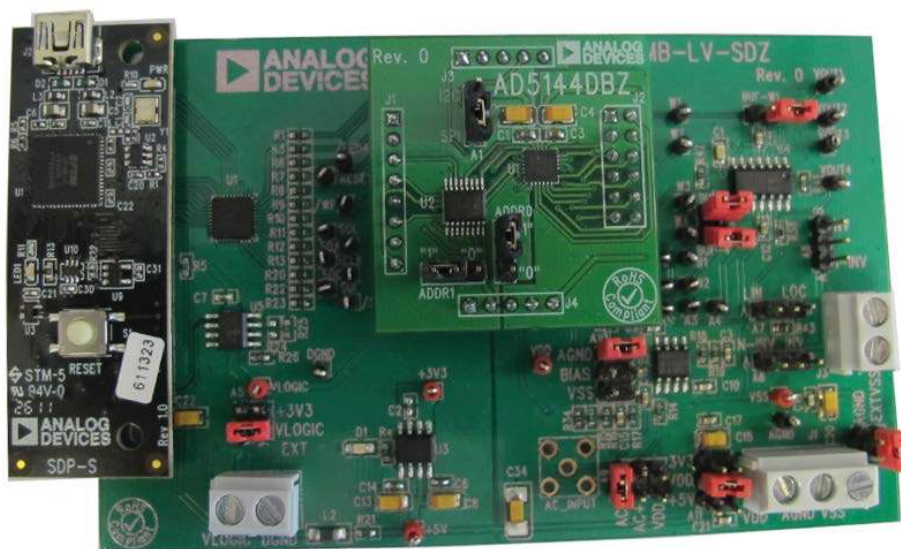

Figure 1. Digital Picture of Evaluation Board with Low Voltage DigiPOT Motherboard and System Demonstration Platform

TABLE OF CONTENTS

Features	1	Evaluation Board Software	8
Package Contents	1	Installing the Software	8
General Description	1	Software Operation	10
EVAL-AD5144DBZ with Motherboard and SDP-S.....	1	Evaluation Board Schematics and Artwork.....	11
Revision History	2	Motherboard	11
Evaluation Board Hardware	3	Daughter Board	15
Power Supplies	3	Ordering Information.....	18
Digital Interface	3	Bill of Materials.....	18
Test Circuits.....	4		

REVISION HISTORY

11/12—Revision 0: Initial Version

EVALUATION BOARD HARDWARE

POWER SUPPLIES

The EVAL-MB-LV-SDZ motherboard supports using single and dual power supplies.

The [EVAL-AD5144DBZ](#) evaluation board can be powered either from the SDP port or externally by the J1 and J2 connectors, as described in Table 1.

All supplies are decoupled to ground using 10 μ F tantalum and 0.1 μ F ceramic capacitors.

Table 1. Maximum and Minimum Voltages of the Connectors

Connector No.	Label	Voltage
J1-1	VDD	Analog positive power supply, V_{DD} . Single supply from 2.3 V to 5.5 V. Dual supply from 2.25 V to 2.75 V.
J1-2	AGND	Analog ground.
J1-3	VSS	Analog negative power supply, V_{SS} . Dual supply from -2.25 V to -2.75 V.
J2-1	VLOGIC	Digital supply, from 1.8 V to V_{DD} .
J2-2	DGND	Digital ground.

Table 3. Link Functions

Link No.	Power Supply	Options
A5	V_{LOGIC}	This link selects one of the following as the digital supply: +3V3 (3.3 V from SDP). VLOGIC EXT (external supply from the J2 connector).
A11	V_{DD}	This link selects one of the following as the positive power supply: +5 V (5 V from SDP). 3V3 (3.3 V from SDP). VDD (external supply from the J1 connector).
A12	V_{SS}	This link selects one of the following as the negative power supply: AGND. EXTVSS (external supply from the J1 connector).

Link Options

Several link and switch options are incorporated in the EVAL-MB-LV-SDZ motherboard and should be set up before using the board. Table 2 describes the positions of the links to control the evaluation board via the SDP board using a PC. The functions of these link options are described in detail in Table 3 through Table 6.

Table 2. Link Options Setup for SDP Control (Default)

Link No.	Option
A5	+3V3
A11	3.3 V
A12	AGND

DIGITAL INTERFACE

The [EVAL-AD5144DBZ](#) can be configured as an I²C or SPI digital interface, depending on the position in the A1 jumper.

If the part is configured in I²C mode, the ADDR0 and ADDR1 jumpers select the I²C address.

TEST CIRCUITS

The [EVAL-AD5144DBZ](#) and EVAL-MB-LV-SDZ incorporate several test circuits to evaluate the performance of the [AD5144](#).

DAC

The digiPOT can be operated as a digital-to-analog converter (DAC), as shown in Figure 2. Table 4 describes the options available for the voltage references.

The output voltage is defined in Equation 1.

$$V_{OUT} = (V_A - V_B) \times \frac{RDAC1}{256} \tag{1}$$

where:

RDAC1 is the code loaded in the RDAC1 register.

V_A is the voltage applied to the A terminal (A9 link).

V_B is the voltage applied to the B terminal (A10 link).

However, by using the R34 and R35 external resistors, the user can reduce the voltage of the voltage references. In this case, use the A1 and B1 test points to measure the voltage applied to the A and B terminals and to recalculate *V_A* and *V_B* in Equation 1.

Table 4. DAC Voltage References

Terminal	Link	Options	Description
A1	A9	AC+ VDD	Connects Terminal A1 to $V_{DD}/2$ Connects Terminal A1 to V_{DD}
W1	BUF-W1		Connects Terminal W1 to an output buffer
B1	A10	BIAS VSS AGND	Connects Terminal B1 to $V_{DD}/2$ Connects Terminal B1 to V_{SS} Connects Terminal B1 to analog ground

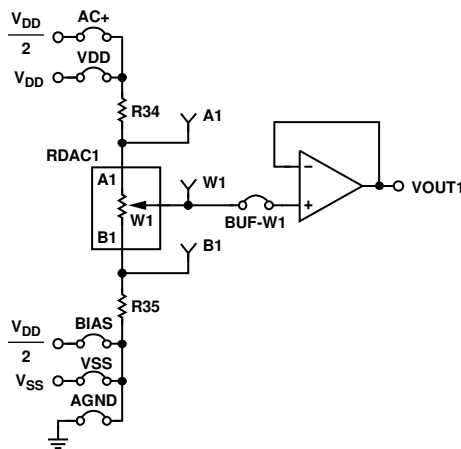

Figure 2. DAC

11006-002

AC Signal Attenuation

The RDAC can be used to attenuate an ac signal, which must be provided externally using the AC_INPUT connector, as shown in Figure 3.

Depending on the voltage supply rails and the dc offset voltage of the ac signal, various configurations can be used as described in Table 5.

The signal attenuation is defined in Equation 2.

$$Attenuation (dB) = 20 \times \log \left(\frac{R_{WB1} + R_W}{R_{AB}} \right) \quad (2)$$

where:

R_W is the wiper resistance.

R_{AB} is the end-to-end resistance value.

R_{WB1} is the resistor between the W1 and B1 terminals.

Table 5. AC Signal Attenuation Link Options

Voltage Supply	Maximum AC Signal Amplitude	Link	Options	Conditions
Single	V_{DD}	A9	AC+	No dc offset voltage; the ac signal is outside the voltage supply rails due to the dc offset voltage; or the dc offset voltage $\neq V_{DD}/2$. ¹
			AC	All other conditions.
Dual	V_{DD}/V_{SS}	A10	BIAS	Use in conjunction with the AC+ link.
			GND	All other conditions.
		A9	AC+	The ac signal is outside the voltage supply rails due to the dc offset voltage; the dc offset voltage $\neq 0 V$. ¹
			AC	All other conditions.
A10	GND	Use in conjunction with the AC+ link.		
VSS	All other conditions.			

¹ Recommended to ensure optimal total harmonic distortion (THD) performance.

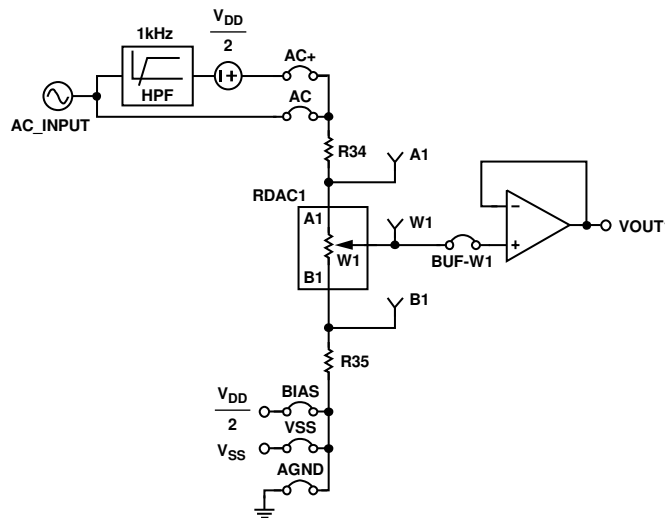

Figure 3. AC Signal Attenuator

11006-003

Signal Amplifier

The RDAC can be operated as an inverting or noninverting signal amplifier supporting linear or pseudologarithmic gains. Table 6 shows the available configurations.

The noninverting amplifier with linear gain is shown in Figure 4, and the gain is defined in Equation 3.

$$G = 1 + \frac{R_{WB2}}{R_{AW2}} \tag{3}$$

where:

R_{WB2} is the code loaded for the R_{WB2} resistance.

R_{AW2} is the code loaded for the R_{AW2} resistance.

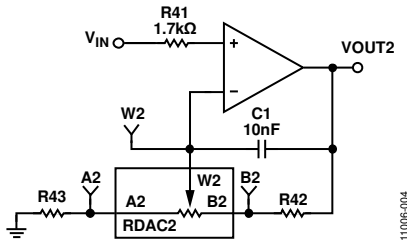

Figure 4. Linear Noninverting Amplifier

R43 and R42 can be used to set the maximum and minimum gain limits.

The noninverting amplifier with pseudologarithmic gain is shown in Figure 5, and the gain is defined in Equation 4.

$$G = 1 + \frac{RDAC2}{256 - RDAC2} \tag{4}$$

where:

$RDAC2$ is the code loaded in the RDAC2.

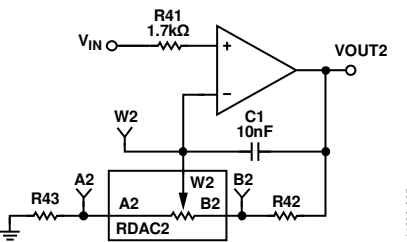

Figure 5. Pseudologarithmic Noninverting Amplifier

R43 and R42 can be used to set the maximum and minimum gain limits.

The inverting amplifier with linear gain is shown in Figure 6, and the gain is defined in Equation 5.

Note that the input signal, V_{IN} , must be negative.

$$G = -\frac{R_{WB2}}{R_{AW2}} \tag{5}$$

where:

R_{WB2} is the code loaded for the R_{WB2} resistance.

R_{AW2} is the code loaded for the R_{AW2} resistance.

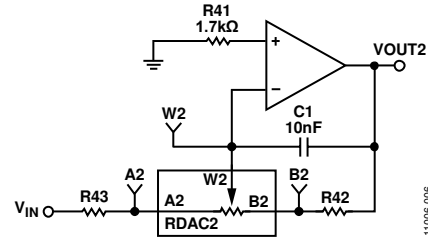

Figure 6. Linear Inverting Amplifier

R43 and R42 can be used to set the maximum and minimum gain limits.

The inverting amplifier with pseudologarithmic gain is shown in Figure 7, and the gain is defined in Equation 6.

$$G = -\frac{RDAC2}{256 - RDAC2} \tag{6}$$

where:

$RDAC2$ is the code loaded in the RDAC2.

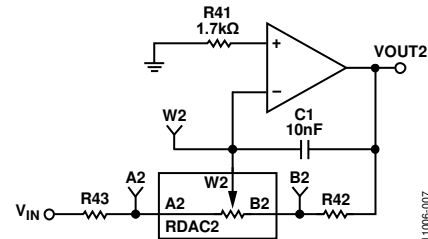

Figure 7. Pseudologarithmic Inverting Amplifier

R43 and R42 can be used to set the maximum and minimum gain limits.

Output Buffers

RDAC3 and RDAC4 can be connected to an output buffer as shown Figure 8 and Figure 9.

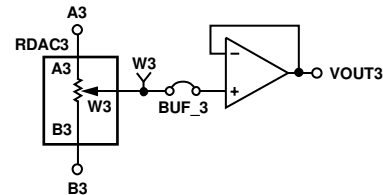

Figure 8. RDAC3

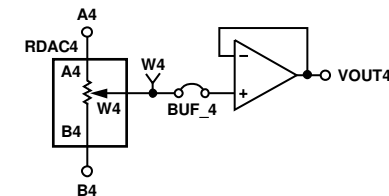

Figure 9. RDAC4

Table 6. Amplifier Selection Link Options

Amplifier	Gain	Linear Setting Gain Mode Enabled	Link	Label
Noninverting	Linear	Yes	A7 A6 A8	LIN N-INV N-INV
	Pseudologarithmic	No	A7 A6 A8	LOG N-INV N-INV
Inverting	Linear	Yes	A7 A6 A8	LIN INV INV
	Pseudologarithmic	No	A7 A6 A8	LOG INV INV

EVALUATION BOARD SOFTWARE

INSTALLING THE SOFTWARE

The [EVAL-AD5144DBZ](#) kit includes a CD containing the evaluation board software. The software is compatible with Windows® XP, Windows Vista, and Windows 7 (both 32 bits and 64 bits).

Install the software before connecting the [SDP board](#) to the USB port of the PC to ensure that the SDP board is recognized when it is connected to the PC.

To install the software,

1. Start the Windows operating system and insert the CD into the CD-ROM drive.
2. The installation software opens automatically. If it does not open automatically, run the **setup.exe** file from the CD.
3. After the installation is complete, power up the evaluation board as described in the Power Supplies section.
4. Connect the [EVAL-AD5144DBZ](#) and EVAL-MB-LV-SDZ to the SDP board, and then connect the SDP board to the PC using the USB cable included with the SDP board.
5. When the software detects the evaluation board, follow the instructions that appear to finalize the installation.

To run the program, do the following:

1. Click **Start > All Programs > Analog Devices > AD5144 > AD5144 Eval Board**. To uninstall the program, click

Start > Control Panel > Add or Remove Programs > AD5144 Eval Board.

2. If the SDP board is not connected to the USB port when the software is launched, a connectivity error displays (see Figure 10). Simply connect the evaluation board to the USB port of the PC, wait a few seconds, click **Rescan**, and follow the instructions.

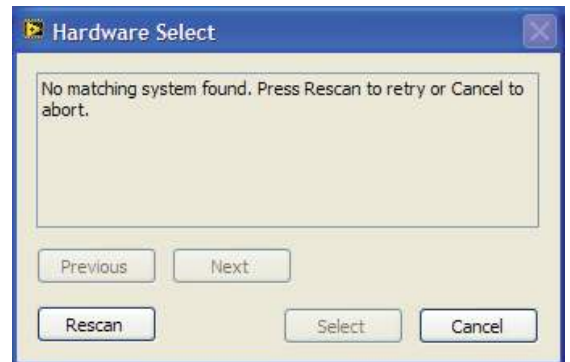

Figure 10. Pop-Up Window Error

The main window of the [EVAL-AD5144DBZ](#) software then opens, as shown in Figure 11.

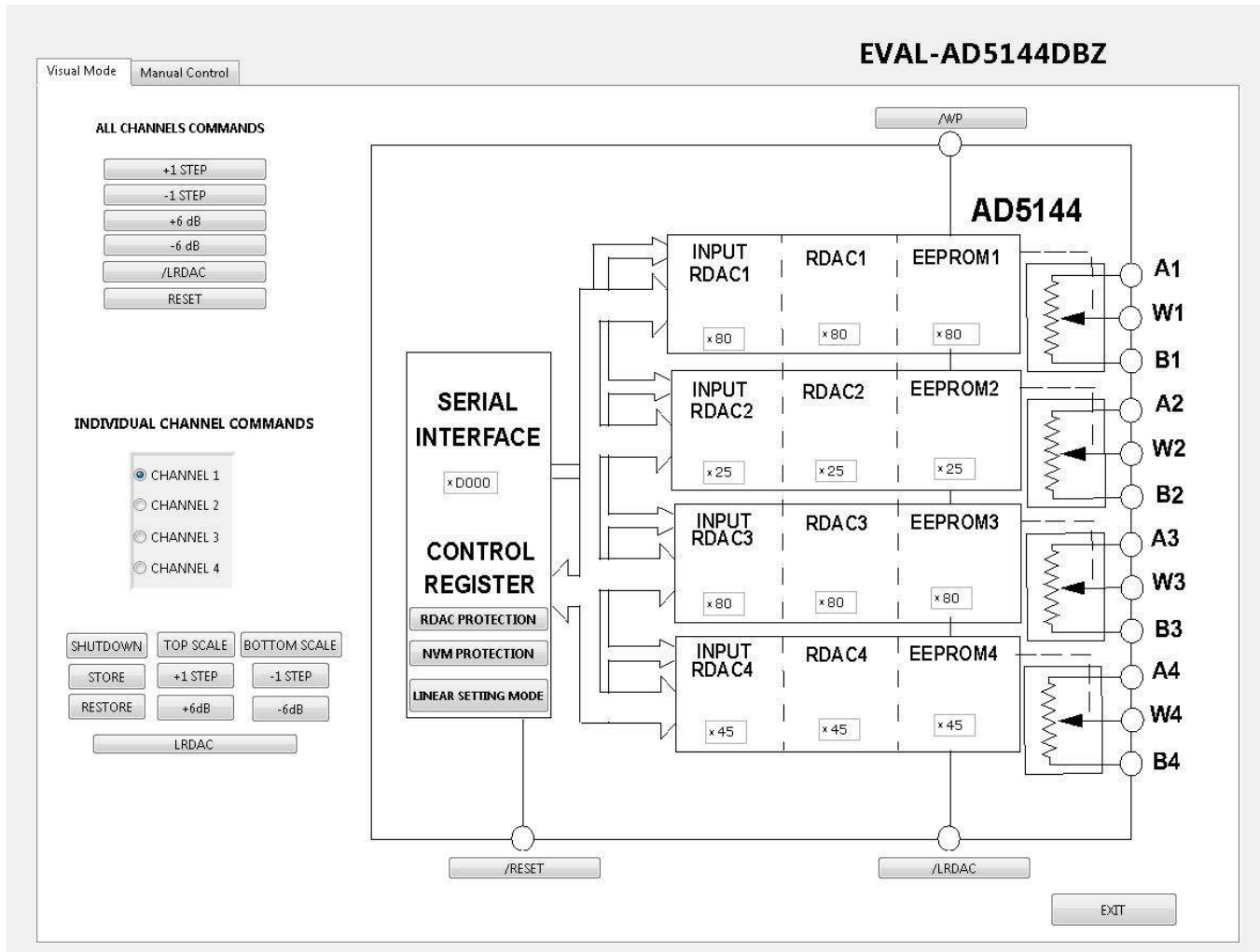

Figure 11. EVAL-AD5144DBZ Software Main Window

11006-022

SOFTWARE OPERATION

The main window of the [EVAL-AD5144DBZ](#) software has two tabs, **Visual Mode** and **Manual Control**.

Visual Mode

The **Visual Mode** tab is divided into the following sections: **ALL CHANNELS COMMANDS**, **INDIVIDUAL CHANNEL COMMANDS**, and a block diagram that contains boxes for changing the control register values and buttons and for controlling the hardware pins.

The **ALL CHANNELS COMMANDS** section allows you to send quick commands directly to the [AD5144](#).

The **INDIVIDUAL CHANNEL COMMANDS** section allows you to send quick commands to only specific channels of the [AD5144](#).

The block diagram allows you to update the control register status. Each register value can be easily updated by changing the

value in its respective block within the diagram. In addition, buttons are available that allow you to change the level of some hardware pins.

Manual Mode

The **Manual Mode** tab, as shown in Figure 12, allows you to customize an I²C data-word by manually switching the scroll bars from 0 to 1 or from 1 to 0, as desired, and then clicking **SEND DATA**.



Figure 12. Manual Mode

11006-023

EVALUATION BOARD SCHEMATICS AND ARTWORK

MOTHERBOARD

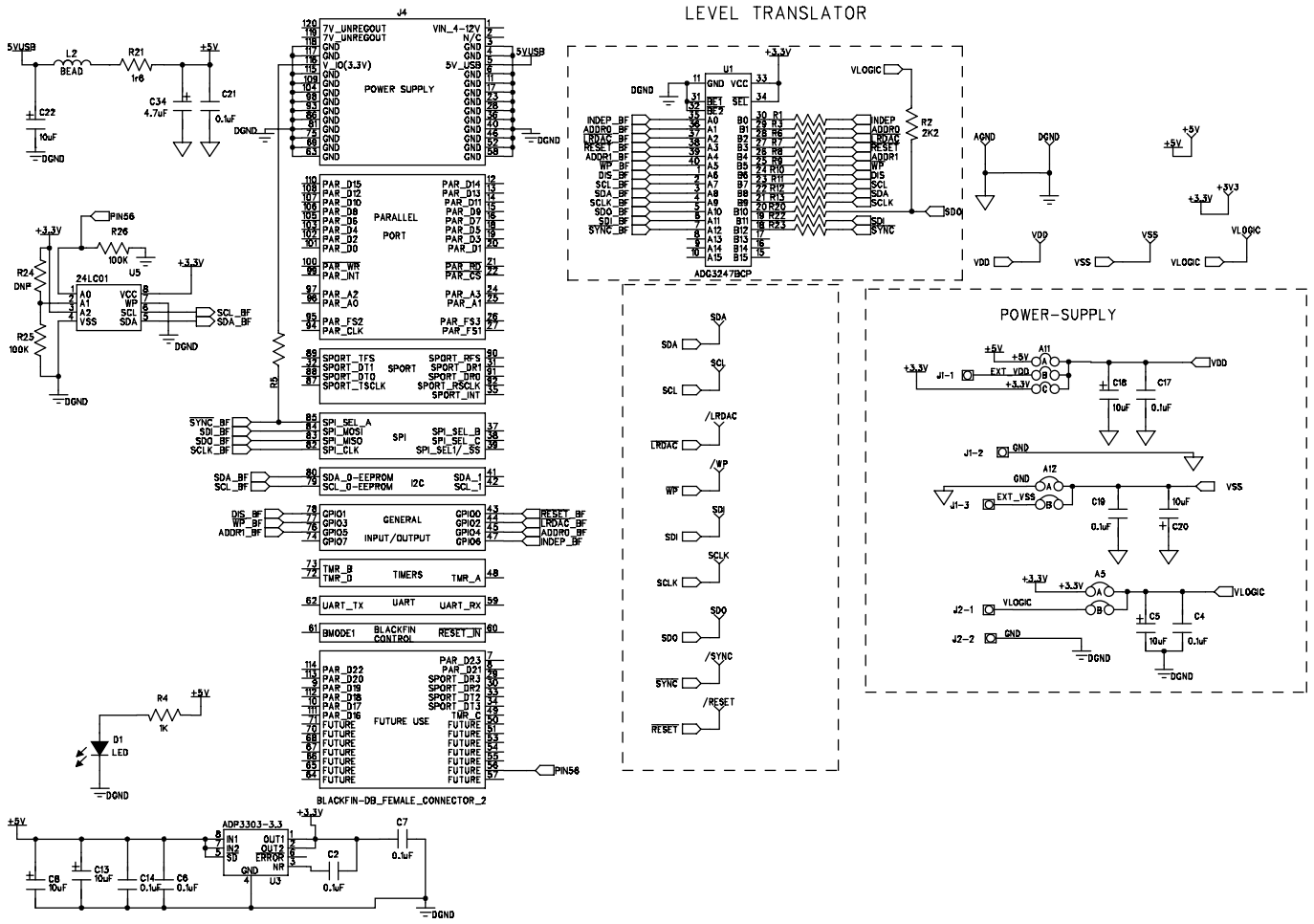
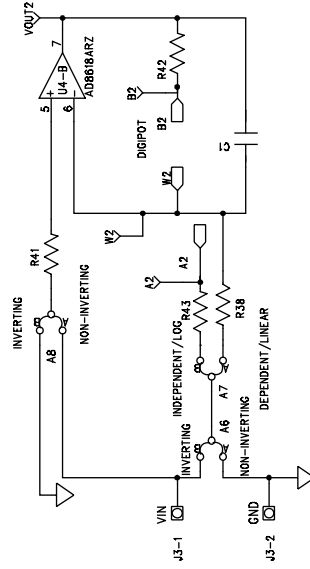
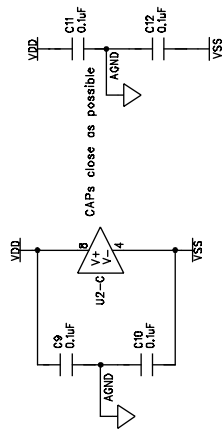
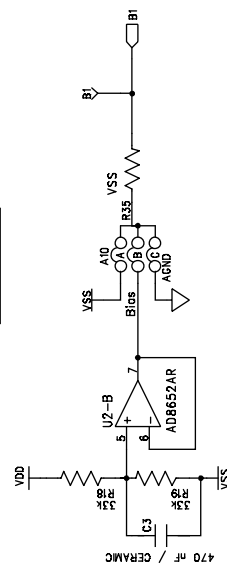
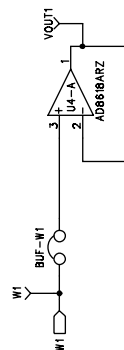
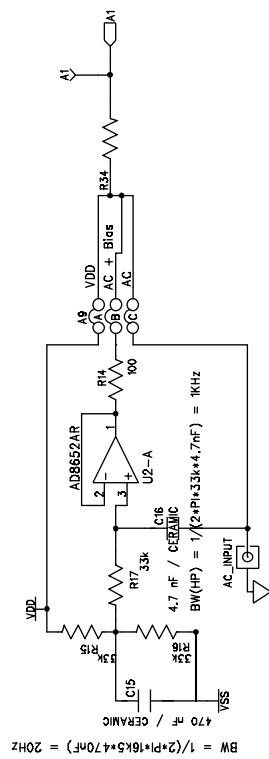
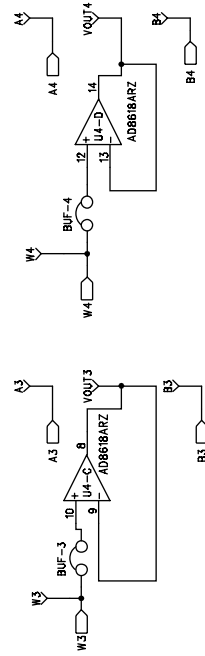

Figure 13. SDP Connector and Power Supply

DAC + FLOATING DAC + BW



INVERTING AND NON-INVERTING WITH LINEAR AND PSEUDO-LOG GAIN



110096-013

Figure 14. Schematic of Test Circuits

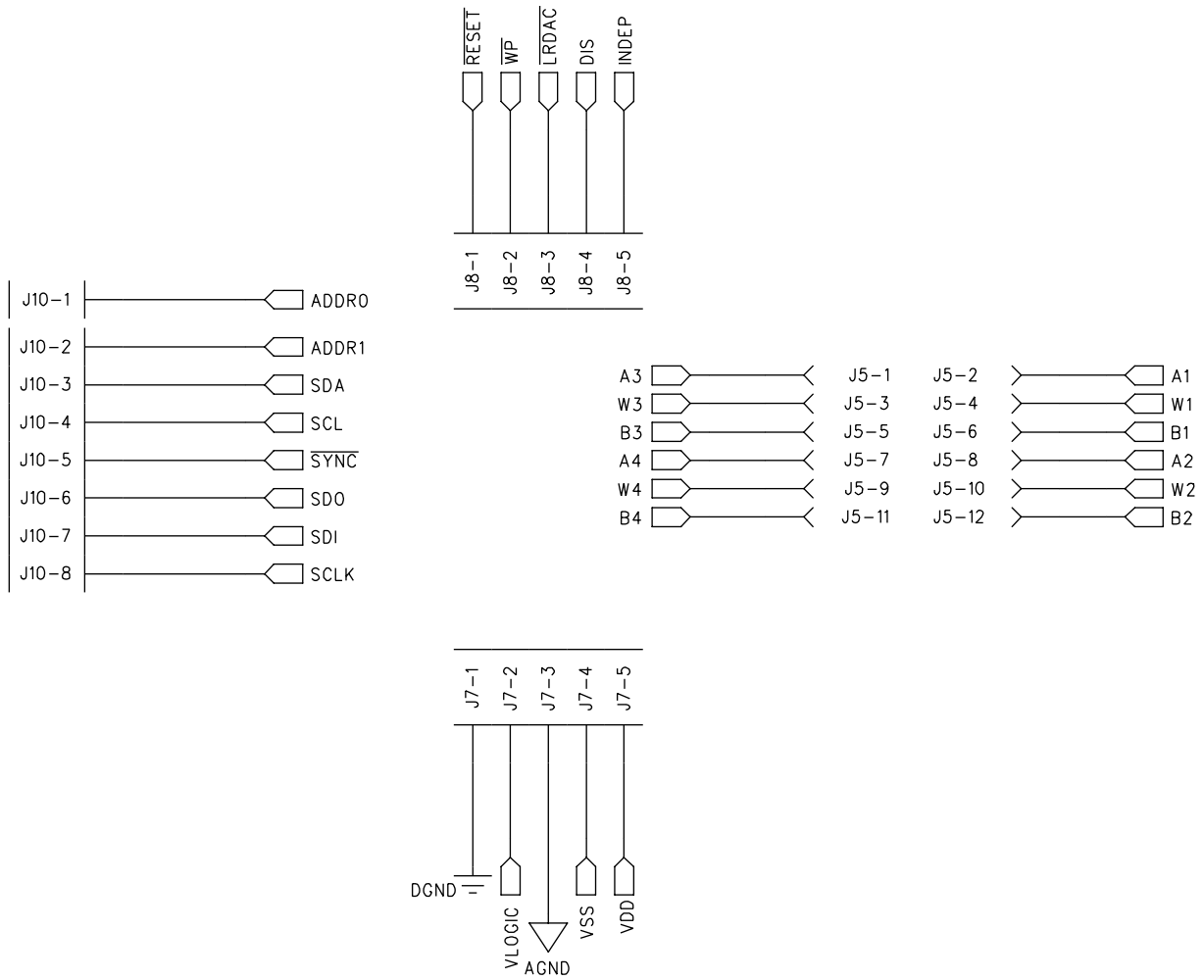

Figure 15. Schematic of Connectors to Daughter Board

11006-014

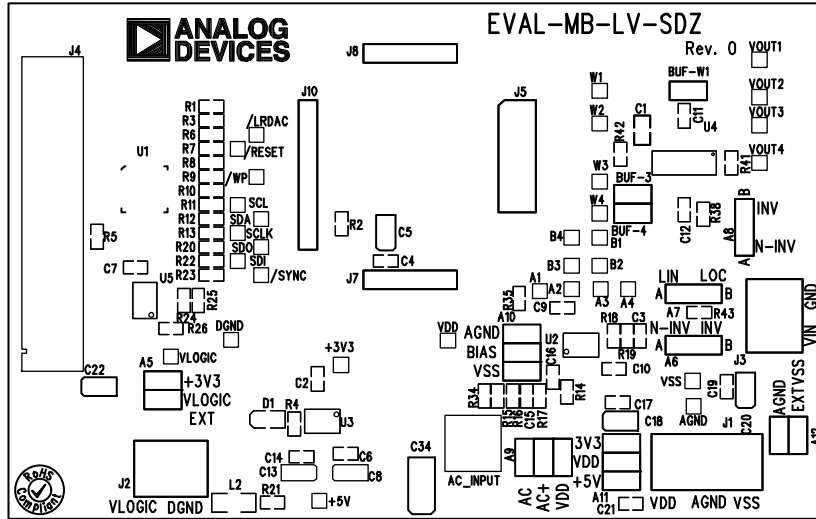

Figure 16. Component Side View of Motherboard

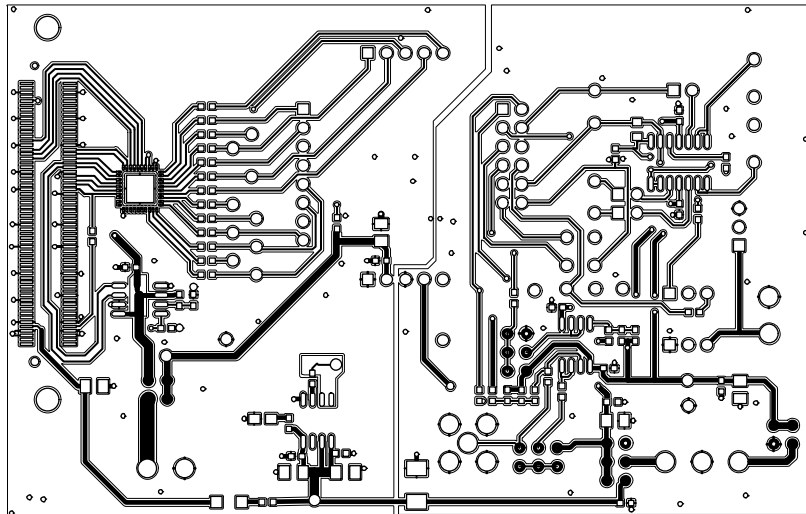

Figure 17. Component Placement Drawing of Motherboard

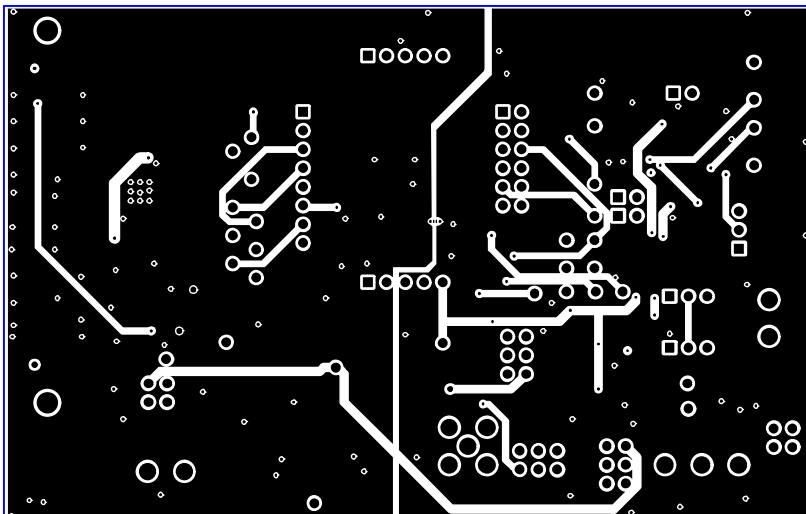

Figure 18. Layer 2 Side PCB Drawing of Motherboard

DAUGHTER BOARD

11006-018

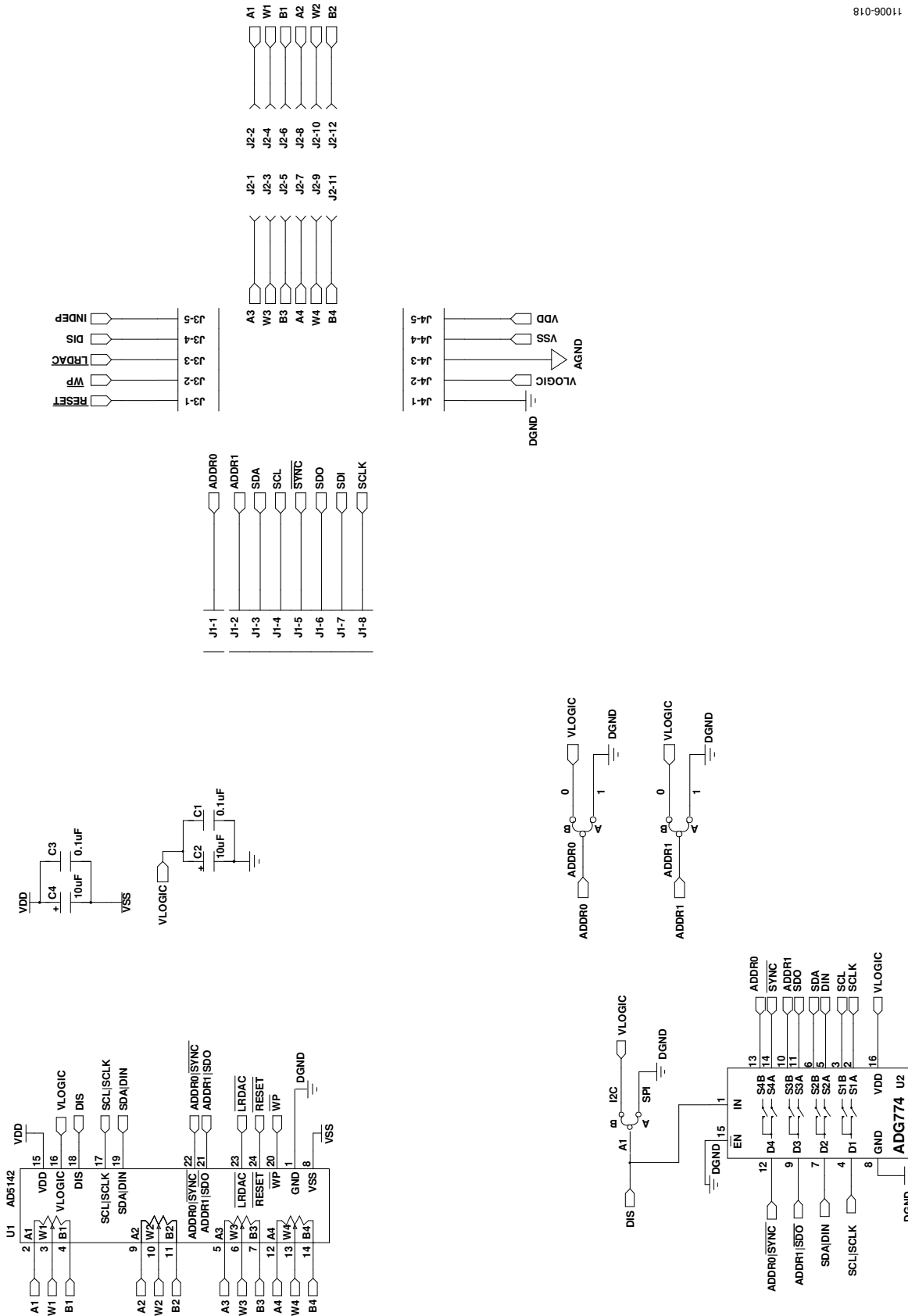

Figure 19. Schematic of Daughter Board

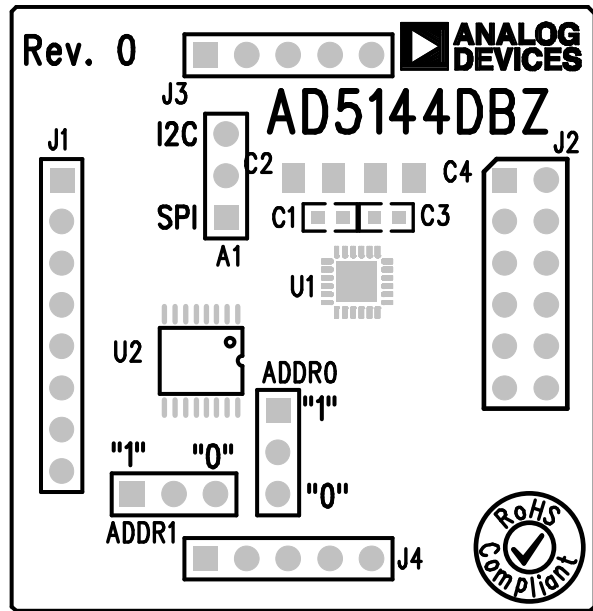

Figure 20. Component Side View of Daughter Board

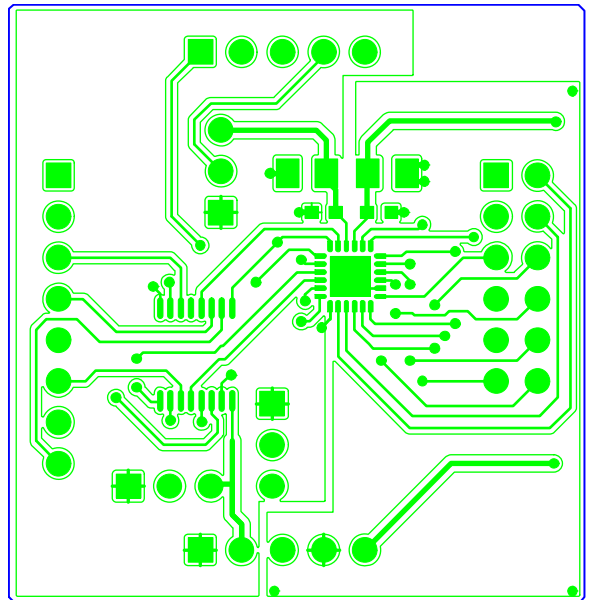

Figure 21. Component Placement Drawing of Daughter Board

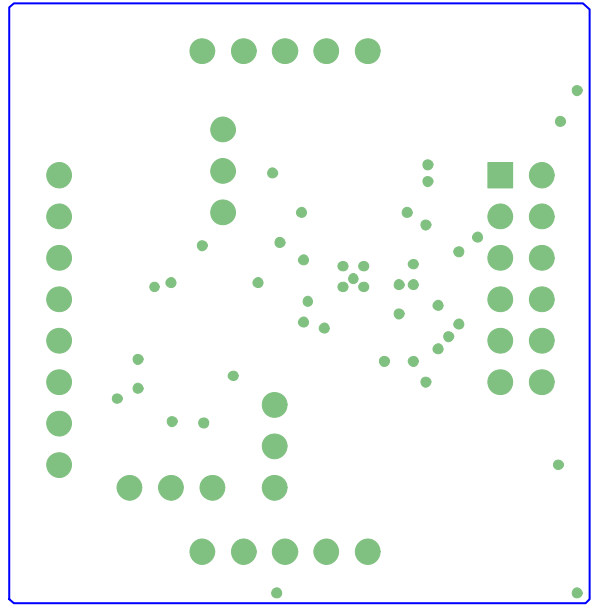

Figure 22. Layer 2 Side PCB Drawing of Daughter Board

11006-021

ORDERING INFORMATION

BILL OF MATERIALS

Table 7. Motherboard

Qty	Reference Designator	Description	Supplier ¹ /Part Number
3	BUF-3, BUF-4, BUF-W1	2-pin (0.1" pitch) header and shorting shunt	FEC 1022247 and 150411
3	A6, A7, A8	3-pin SIL header and shorting link	FEC 1022248 and 150410
5	A5, A9, A10, A11, A12	6-pin (3 × 2), 0.1" header and shorting block	FEC 672014 and 150411 (36-pin strip)
1	J1	3-pin terminal block (5 mm pitch)	FEC 151790
2	J7, J8	4-pin SIL header	FEC 1098035
1	J4	Receptacle, 0.6 mm, 120-way	Digi-Key H1219-ND
1	J10	8-pin in-line header; 100 mil centers	FEC 1098038
1	J5	12-pin (2 × 6), 0.1" pitch header	FEC 1098051
2	J2, J3	2-pin terminal block (5 mm pitch)	FEC 151789
17	R1, R3, R6, R7, R8, R9, R10, R11, R12, R13, R20, R22, R23, R34, R35, R42, R43	SMD resistor, 0 Ω, 0.01, 0603	FEC 9331662
1	R2	SMD resistor, 2.2 kΩ, 0.01, 0603	FEC 1750676
1	R41	SMD resistor, 1.7 kΩ, 1%, 0603	FEC 1170811
1	R21	Resistor, surge, 1.6 Ω, 1%, 0603	FEC 1627674
1	R38	SMD resistor, 2.7 kΩ, 1%, 0603	FEC 1750678
1	R14	SMD resistor, 100 Ω, 1%, 0603	FEC 9330364
1	R4	SMD resistor, 1 kΩ, 0.01, 0603	FEC 9330380
3	R5, R25, R26	SMD resistor, 100 kΩ, 1%, 0603	FEC 9330402
5	R15, R16, R17, R18, R19	SMD resistor, 33 kΩ, 1%, 0603	FEC 9331034
1	C1	SMD capacitor, 100 nF, 10%, 0805	FEC 1650863
8	C4, C9, C10, C11, C12, C17, C19, C21	SMD capacitor, 0.1 μF, ±10%, 0603	FEC 1759122
4	C2, C6, C7, C14	SMD capacitor, 0.1 μF, ±10%, 0603	FEC 3019482
2	C8, C13	SMD capacitor, 10 μF, ±10%	FEC 197130
4	C18, C20, C22, C5	Capacitor, 10 μF, ±20%	FEC 1190107
2	C3, C15	Capacitor, 470 nF, ±10%, 0603	FEC 1414037
1	C16	Capacitor, 4.7 nF, ±10%, 0603	FEC 1414642
1	C34	Capacitor, 4.7 nF, ±20%	FEC 1432350
1	L2	Inductor, SMD, 600Z	FEC 9526862
1	D1	Green SMD LED	FEC 5790852
1	U1	Two-port level translating bus switch	ADG3247BCPZ
1	U2	Dual op amp	AD8652ARZ
1	U3	Precision low dropout voltage regulator	ADP3303ARZ-3.3
1	U4	Operational amplifier	AD8618ARZ
1	U5	I ² C serial EEPROM 64k 2.5 V MSOP-8	FEC 1331335
18	LRDAC, RESET, SYNC, WP, A1, A2, A3, A4, AGND, B1, VOUT_C1, VOUT_C2, VOUT3, VOUT4, W1, W2, W3, W4	Terminal, PCB, black, PK100, test point	FEC 8731128
5	+3.3V, +5V, EXT_VDD, VLOGIC, EXT_VSS	Terminal, PCB, red, PK100, test point	FEC 8731144

¹ FEC refers to Farnell Electronic Component Distributors; Digi-Key refers to Digi-Key Corporation.

Table 8. Daughter Board

Qty	Reference Designator	Description	Supplier ¹ /Part Number
1	U1	256-position digital potentiometer	AD5144BCPZ10
1	U2	Low voltage quad SPDT switch	ADG774BRQZ
3	A1, ADDR0, ADDR1	3-pin SIL header and shorting link	FEC 1022248 and 150410
2	C2, C4	6.3 V tantalum capacitor (Case A), 10 μ F, \pm 20%	FEC 1190107
2	C1, C3	50 V, X7R ceramic capacitor, 0.1 μ F, \pm 10%	FEC 1759122
1	J1	Header, 2.54 mm, PCB, 1 \times 8-way	FEC 1766172
1	J2	12-pin (2 \times 6), 0.1" pitch header	FEC 1804099
2	J3, J4	5-pin SIL header	FEC 1929016

¹ FEC refers to Farnell Electronic Component Distributors.

NOTES

I²C refers to a communications protocol originally developed by Philips Semiconductors (now NXP Semiconductors).

**ESD Caution**

ESD (electrostatic discharge) sensitive device. Charged devices and circuit boards can discharge without detection. Although this product features patented or proprietary protection circuitry, damage may occur on devices subjected to high energy ESD. Therefore, proper ESD precautions should be taken to avoid performance degradation or loss of functionality.

Legal Terms and Conditions

By using the evaluation board discussed herein (together with any tools, components documentation or support materials, the "Evaluation Board"), you are agreeing to be bound by the terms and conditions set forth below ("Agreement") unless you have purchased the Evaluation Board, in which case the Analog Devices Standard Terms and Conditions of Sale shall govern. Do not use the Evaluation Board until you have read and agreed to the Agreement. Your use of the Evaluation Board shall signify your acceptance of the Agreement. This Agreement is made by and between you ("Customer") and Analog Devices, Inc. ("ADI"), with its principal place of business at One Technology Way, Norwood, MA 02062, USA. Subject to the terms and conditions of the Agreement, ADI hereby grants to Customer a free, limited, personal, temporary, non-exclusive, non-sublicensable, non-transferable license to use the Evaluation Board FOR EVALUATION PURPOSES ONLY. Customer understands and agrees that the Evaluation Board is provided for the sole and exclusive purpose referenced above, and agrees not to use the Evaluation Board for any other purpose. Furthermore, the license granted is expressly made subject to the following additional limitations: Customer shall not (i) rent, lease, display, sell, transfer, assign, sublicense, or distribute the Evaluation Board; and (ii) permit any Third Party to access the Evaluation Board. As used herein, the term "Third Party" includes any entity other than ADI, Customer, their employees, affiliates and in-house consultants. The Evaluation Board is NOT sold to Customer; all rights not expressly granted herein, including ownership of the Evaluation Board, are reserved by ADI. CONFIDENTIALITY. This Agreement and the Evaluation Board shall all be considered the confidential and proprietary information of ADI. Customer may not disclose or transfer any portion of the Evaluation Board to any other party for any reason. Upon discontinuation of use of the Evaluation Board or termination of this Agreement, Customer agrees to promptly return the Evaluation Board to ADI. ADDITIONAL RESTRICTIONS. Customer may not disassemble, decompile or reverse engineer chips on the Evaluation Board. Customer shall inform ADI of any occurred damages or any modifications or alterations it makes to the Evaluation Board, including but not limited to soldering or any other activity that affects the material content of the Evaluation Board. Modifications to the Evaluation Board must comply with applicable law, including but not limited to the RoHS Directive. TERMINATION. ADI may terminate this Agreement at any time upon giving written notice to Customer. Customer agrees to return to ADI the Evaluation Board at that time. LIMITATION OF LIABILITY. THE EVALUATION BOARD PROVIDED HEREUNDER IS PROVIDED "AS IS" AND ADI MAKES NO WARRANTIES OR REPRESENTATIONS OF ANY KIND WITH RESPECT TO IT. ADI SPECIFICALLY DISCLAIMS ANY REPRESENTATIONS, ENDORSEMENTS, GUARANTEES, OR WARRANTIES, EXPRESS OR IMPLIED, RELATED TO THE EVALUATION BOARD INCLUDING, BUT NOT LIMITED TO, THE IMPLIED WARRANTY OF MERCHANTABILITY, TITLE, FITNESS FOR A PARTICULAR PURPOSE OR NONINFRINGEMENT OF INTELLECTUAL PROPERTY RIGHTS. IN NO EVENT WILL ADI AND ITS LICENSORS BE LIABLE FOR ANY INCIDENTAL, SPECIAL, INDIRECT, OR CONSEQUENTIAL DAMAGES RESULTING FROM CUSTOMER'S POSSESSION OR USE OF THE EVALUATION BOARD, INCLUDING BUT NOT LIMITED TO LOST PROFITS, DELAY COSTS, LABOR COSTS OR LOSS OF GOODWILL. ADI'S TOTAL LIABILITY FROM ANY AND ALL CAUSES SHALL BE LIMITED TO THE AMOUNT OF ONE HUNDRED US DOLLARS (\$100.00). EXPORT. Customer agrees that it will not directly or indirectly export the Evaluation Board to another country, and that it will comply with all applicable United States federal laws and regulations relating to exports. GOVERNING LAW. This Agreement shall be governed by and construed in accordance with the substantive laws of the Commonwealth of Massachusetts (excluding conflict of law rules). Any legal action regarding this Agreement will be heard in the state or federal courts having jurisdiction in Suffolk County, Massachusetts, and Customer hereby submits to the personal jurisdiction and venue of such courts. The United Nations Convention on Contracts for the International Sale of Goods shall not apply to this Agreement and is expressly disclaimed.