

Relay Technical Information

Definition of Relay Terminology

COIL (also referred to as primary or input)

- **Nominal Coil Voltage** (Rated Coil Voltage)

A single value (or narrow range) of source voltage intended by design to be applied to the coil or input.

- **Pick-Up Voltage** (Pull-In Voltage or Must Operate Voltage)

As the voltage on an unoperated relay is increased, the value at or below which all contacts must function (transfer).

- **Drop-Out Voltage** (Release or Must Release Voltage)

As the voltage on an operated relay is

- **Coil Designation**

decreased, the value at or above which all contacts must revert to their unoperated position.

- **Maximum Continuous Voltage**

The maximum voltage that can be applied continuously to the coil without causing damage. Short duration spikes of a higher voltage may be tolerable, but this should not be assumed without first checking with the manufacturer.

- **Nominal Operating Current**



The value of current flow in the coil when nominal voltage is impressed on the coil

- **Nominal Operating Power**

The value of power used by the coil at nominal voltage. For DC coils expressed in watts; AC expressed as volt amperes. Nominal Power (W or VA) = Nominal Voltage × Nominal Current.

- **Coil Resistance**

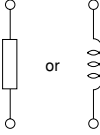
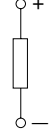
This is the DC resistance of the coil in DC type relays for the temperature conditions listed in the catalog. (Note that for certain types of relays, the DC resistance may be for temperatures other than the standard 20°C 68°F.)

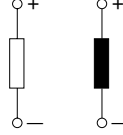
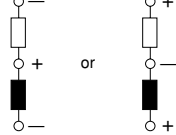
Single side stable type		1 coil latching type	2 coil latching type	
Non-polarized	Polarized		4-terminal	3-terminal
				

A black coil represents the energized state. For latching relays, schematic

diagrams generally show the coil in its reset state. Therefore, the coil symbol is



also shown for the reset coil in its reset state.

CONTACTS (secondary or output)

- **Contact Forms**

Denotes the contact mechanism and number of contacts in the contact circuit.

- **Contact Symbols**

Form A contacts (normally open contacts)	
Form B contacts (normally closed contacts)	
Form C contacts (changeover contacts)	

Form A contacts are also called N.O. contacts or make contacts.

Form B contacts are also called N.C. contacts or break contacts.

Form C contacts are also called changeover contacts or transfer contacts.

- **MBB Contacts**

Abbreviation for make-before-break contacts. Contact mechanism where Form A contacts (normally open contacts) close before Form B contacts open (normally closed contacts).

- **Rated Switching Power**

The design value in watts (DC) or volt

amperes (AC) which can safely be switched by the contacts. This value is the product of switching voltage x switching current, and will be lower than the maximum voltage and maximum current product.

- **Maximum Switching Voltage**

The maximum open circuit voltage which can safely be switched by the contacts. AC and DC voltage maximums will differ in most cases.

- **Maximum Switching Current**

The maximum current which can safely be switched by the contacts. AC and DC current maximums may differ.

- **Maximum Switching Power**

The upper limit of power which can be switched by the contacts. Care should be taken not to exceed this value.

- **Maximum Carrying Current**

The maximum current which after closing or prior to opening, the contacts can safely pass without being subject to temperature rise in excess of their design limit, or the design limit of other temperature sensitive components in the relay (coil, springs, insulation, etc.). This value is usually in excess of the maximum switching current.

- **Minimum switching capability**

This value is a guideline as to the lowest possible level at which it will be possible for a low level load to allow switching. The level of reliability of this value depends on switching frequency, ambient conditions, change in the desired contact resistance, and the absolute value. Please use a relay with AgPd contacts if your needs analog low level loads, control, or a contact resistance of 100 mΩ or less. We recommend that you verify with one of our sales offices regarding usage.

- **Maximum Switching Capacity**

This is listed in the data column for each type of relay as the maximum value of the contact capacity and is an interrelationship of the maximum switching power, maximum switching voltage, and maximum switching current. The switching current and switching voltage can be obtained from this graph. For example, if the switching voltage is fixed in a certain application, the maximum switching current can be obtained from the intersection between the voltage on the axis and the maximum switching power.

Maximum Switching Capacity (TX relay)

Example: Using TX relay at a switching voltage of 60V DC, the maximum switching current is 1A. (Maximum switching capacity is given for a resistive load. Be sure to carefully check the actual load before use.)

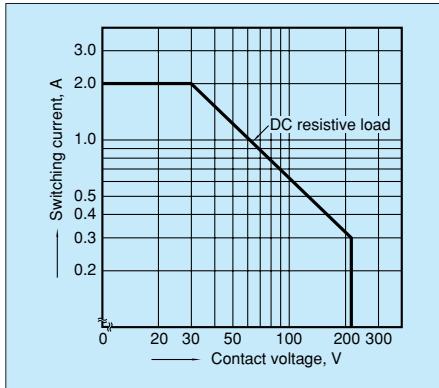

• Contact Resistance

This value is the combined resistance of the resistance when the contacts are touching each other, the resistance of the terminals and contact spring. The contact resistance is measured using the voltage-drop method as shown below. The measuring currents are designated in Fig. 1.

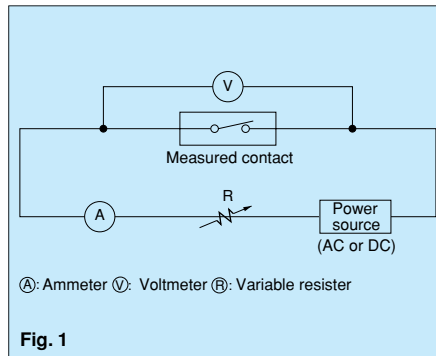

Test Currents

Rated Contact Current or Switching Current (A)	Test Current (mA)
Less than 0.01	1
0.01 or more and less than 0.1	10
0.1 or more and less than 1	100
1 or more	1,000

The resistance can be measured with reasonable accuracy on a YHP 4328A milliohm meter.

In general, for relays with a contact rating of 1A or more, measure using the voltage-drop method at 1A 6V DC.

• Capacitance

This value is measured between the terminals at 1kHz and 20°C 68°F.

PERFORMANCE

• Insulation Resistance

The resistance value between all mutually isolated conducting sections of the relay, i.e. between coil and contacts, across open contacts and between coil or contacts to any core or frame at ground potential. This value is usually expressed as "initial insulation resistance" and may decrease with time, due to material degradation and the accumulation of contaminants.

• Breakdown Voltage (Hi-Pot or Dielectric Strength)

The maximum voltage which can be tolerated by the relay without damage for a specified period of time, usually measured at the same points as insulation resistance. Usually the stated value is in VAC (RMS) for one minute duration.

• Surge Withstand Voltage

The ability of the device to withstand an abnormal externally produced power surge, as in a lightning strike, or other phenomenon. An impulse test waveform is usually specified, indicating rise time, peak value and fall time. (Fig. 2)

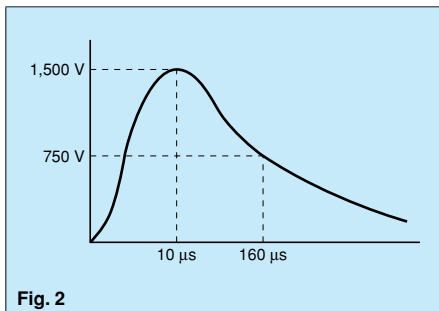

• Operate Time (Pull-In or Pick-Up Time)

The elapsed time from the initial application of power to the coil, until the

closure of the normally open contacts. (With multiple pole devices the time until the last contact closes.) This time does not include any bounce time.

• Release Time (Drop-Out Time)

The elapsed time from the initial removal of coil power until the reclosure of the normally closed contacts (last contact with multi-pole) this time does not include bounce.

• Set Time

Term used to describe operate time of a latching relay.

• Reset Time

Term used to describe release time of a latching relay. With a 2-coil magnetic latching relay the time is from the first application of power to the reset coil until the reclosure of the reset contacts. With a single coil latching relay, the time is measured from the first application of reverse coil voltage until the reclosure of the reset contact.

• Contact Bounce (Time)

Generally expressed in time (ms), this refers to the intermittent switching phenomenon of the contacts which occurs due to the collision between the movable metal parts or contacts, when the relay is operated or released.

• Operate Bounce Time

The time period immediately following operate time during which the contacts are still dynamic, and ending once all bounce has ceased.

• Release Bounce Time

The time period immediately following release time during which the contacts are still dynamic, ending when all bounce has ceased.

• Shock Resistance, Destructive

The acceleration which can be withstood by the relay during shipping or installation without it suffering damage, and without causing a change in its operating characteristics. Usually expressed in "G"s.

• Shock Resistance, Functional

The acceleration which can be tolerated by the relay during service without causing the closed contacts to open for more than the specified time. (usually 10μs)

• Vibration Resistance, Destructive

The vibration which can be withstood by the relay during shipping, installation or use without it suffering damage, and without causing a change in its operating characteristics. Expressed as an acceleration in G's or displacement, and frequency range.

• Vibration Resistance, Functional

The vibration which can be tolerated by the relay during service, without causing the closed contacts to open for more than the specified time.

• Mechanical Life

The minimum number of times the relay can be operated under nominal conditions (coil voltage, temperature, humidity, etc.) with no load on the contacts.

• Electrical Life

The minimum number of times the relay can be operated under nominal conditions with a specific load being switched by the contacts.

• Maximum Switching Frequency

This refers to the maximum switching frequency which satisfies the mechanical life or electrical life under repeated operations by applying a pulse train at the rated voltage to the operating coil.

Definition of Relay Terminology

• Life Curve

This is listed in the data column for each type of relay. The life (number of operations) can be estimated from the switching voltage and switching current. For example, for a DS relay operating at: Switching voltage = 125V AC Switching current = 0.6A The life expectancy is 300,000 operations. However, this value is for a resistive load. Be sure to carefully check the actual load before use.

Life Curve

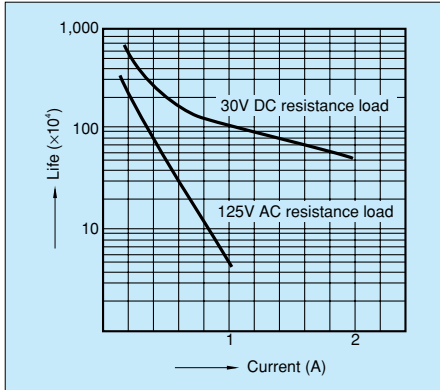

HIGH FREQUENCY CHARACTERISTICS

• Isolation

High frequency signals leak through the stray capacitance across contacts even if the contacts are separated. This leak is called isolation. The symbol dB (decibel) is used to express the magnitude of the leak signal. This is expressed as the logarithm of the magnitude ratio of the signal generated by the leak with respect to the input signal. The larger the magnitude, the better the isolation.

• Insertion Loss

At the high frequency region, signal disturbance occurs from self-induction, resistance, and dielectric loss as well as from reflection due to impedance mismatching in circuits. Loss due to any of these types of disturbances is called insertion loss. Therefore, this refers to the magnitude of loss of the input signal. The smaller the magnitude, the better the relay.

• V.S.W.R. (Voltage Standing Wave Ratio)

High frequency resonance is generated from the interference between the input signal and reflected (wave) signal. V.S.W.R. refers to the ratio of the maximum value to minimum value of the waveform. The V.S.W.R. is 1 when there is no reflected wave. It usually becomes greater than 1.

Notes:

1. Except where otherwise specified, the tests above are conducted under standard temperature and humidity (15°C to 35°C 59°F to 95°F, 25 to 75%).
2. The coil impressed voltage in the switching tests is a rectangular wave at the rated voltage.
3. The phase of the AC load operation is random.

PROTECTIVE CONSTRUCTION

Several different degrees of protection are provided for different relay types, for resistance to dust, flux, contaminating environments, automatic cleaning, etc.

• Open Type

For reasons of cost, some devices are not provided with any enclosure. It is usually assumed that the end application will be in an overall enclosure or protective environment.

• Dust Cover Type

Most standard relays are provided with a dust cover of some type. This protects the relay from large particulate

contamination, and also may protect user personnel from a shock hazard.

• Flux-Resistant Type

In this type of construction, solder flux penetration is curtailed by either insert molding the terminals with the header, or by a simple sealing operation during manufacturing.

• Sealed Type

This type of sealed relay totally excludes the ingress of contaminants by way of a sealing compound being applied to the header/cover interface. The constituent components are annealed for physical

and chemical stability. This annealing process drives off residual volatiles in the plastics, insuring a contaminant free environment inside the sealed relay, resulting in more stable contact resistance over life.

• Hermetic Seal

The plastic sealed type is not a true hermetic seal, there is an exchange of gas molecules through the plastic cover over time. The only true hermetic seals are metal to metal and glass to metal. The entire device is purged with dry nitrogen gas prior to sealing, improving reliability.

CONSTRUCTION AND CHARACTERISTIC

(○: Yes, ×: No)

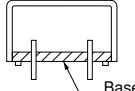
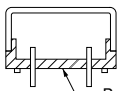
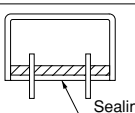
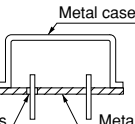
Type	Construction	Characteristics	Automatic Soldering	Automatic Cleaning	Harmful Gas Resistance
Dust Cover Type		Most basic construction where the case and base (or body) are fitted together.	×	×	×
Flux-Resistant Type		Terminals are sealed or molded simultaneously. The joint between the case and base is higher than the surface of the PC board.	○	×	×
Sealed Type		Terminals, case, and base are filled with sealing resin.	○	○	○
Metallic Hermetic Seal Type		Hermetically sealed with metal case and metal base. Terminals are sealed with glass.	○	○	○

OPERATIONAL FUNCTION

• Single Side Stable Type

Relay which turns on when the coil is energized and turns off when de-energized. (Fig. 3)

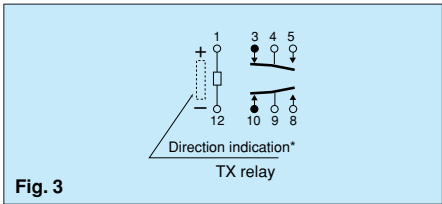

Fig. 3

• 1 Coil Latching Type

Relay with a latching construction that can maintain the on or off state with a pulse input. With one coil, the relay is set or reset by applying signals of opposite polarities. (Fig. 4)

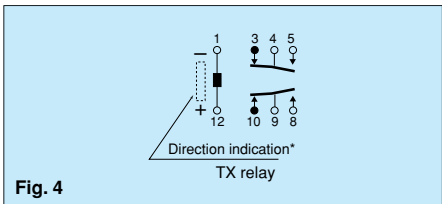

Fig. 4

• 2 Coil Latching Type

Relay with a latching construction composed of 2 coils: set coil and reset coil. The relay is set or reset by alternately applying pulse signals of the same polarity. (Fig. 5)

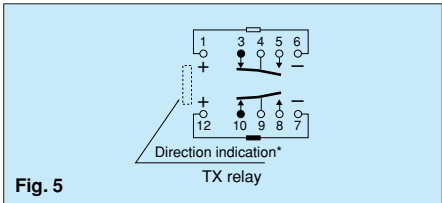

Fig. 5

• Operation Indication

Indicates the set and reset states either electrically or mechanically for easy maintenance. An LED wired type (LED wired HC relay), lamp type (lamp wired HP relay) are available. (Fig. 6)



Fig. 6

TERMINAL CONFIGURATION

Type	PC board through hole terminal	PC board self-clinching terminal	PC board surface-mount terminal	Plug-in terminal	Quick connect terminal	Screw terminal
Typical relay type						
Terminal configuration						
Typical relay type	GQ, GN, TQ, TN, TK, TX, TX-D relay, DS relay, DS-BT relay, RP relay, JS relay, JW relay, SEB relay, JQ relay, PQ relay	TQ, TN, TK, TX, TX-D relay	GQ-SMD, GN-SMD, TX-SMD, TQ-SMD	HJ relay, HC relay, HP relay, HE relay, HL relay, HK relay, HN relay	JC relay, JR relay	HE relay, EP relay, EJ relay

MOUNTING METHOD

Type	Insertion mount	Surface mount	Socket mount	Terminal socket mount	TM relay	TMP type
Mounting configuration						
Typical relay type	GQ, GN, TQ, TN, TK, TX, TX-D relay, DS relay, DS-BT relay, RP relay, SEB relay	GQ-SMD, GN-SMD, TX-SMD, TQ-SMD	NC relay, HC relay, HL relay	HJ relay, HC relay, HP relay, HG relay, HL relay, HK relay, HN relay	HC relay, JR relay, JC relay	JR relay, LF relay, JT-N relay

Notes: 1. Sockets are available for certain PC board relays. (SEB relay, ST relay, etc.)
2. M type (solder type) for direct screw mounting of case is also available. (HG relay)

General Application Guidelines

A relay may encounter a variety of ambient conditions during actual use resulting in unexpected failure. Therefore,

testing over a practical range under actual operating conditions is necessary. Application considerations should be

reviewed and determined for proper use of the relay.

CAUTIONS REGARDING SAFETY

- Be absolutely sure not to exceed the specification ranges, such as coil rating, contact rating and switching life. Doing so may lead to abnormal heating, smoke, and fire.
- Be absolutely sure not to touch the charging part when the relay is on. Doing so may cause electrical shock. Be sure to

turn off the power when installing, maintaining and troubleshooting the relay (including connecting parts such as the terminal block and socket).

- Perform terminal connections correctly after verifying the internal wiring diagrams in the catalog. Connecting incorrectly may cause unexpected malfunction, abnormal

heating, and fire, etc.

- Prepare with a redundant safety device construction if there is a possibility that such things as adhesion, contact failure or disconnection could cause bodily harm or property damage.

METHOD OF DETERMINING SPECIFICATIONS

Failsafe

	Specification item	Consideration points regarding selection
Coil	a) Rating b) Pick-up voltage (current) c) Drop-out voltage (current) d) Maximum continuous impressed voltage (current) e) Coil resistance f) Impedance g) Temperature rise h) Input frequency for AC type	1) Select relay with consideration for power source ripple. 2) Give sufficient consideration to ambient temperature, for the coil temperature rise and hot start. 3) When used in conjunction with semiconductors, additional attention to the application should be taken.
Contacts	a) Contact arrangement b) Contact rating c) Contact material d) Life e) Contact pressure f) Contact resistance	1) It is desirable to use a standard product with more than the required number of contacts. 2) It is beneficial to have the relay life balanced with the life of the device it is used in. 3) Is the contact material matched to the type of load? It is necessary to take care particularly with low level usage. 4) The rated life may become reduced when used at high temperatures. Life should be verified in the actual atmosphere used. 5) Depending on the circuit, the relay drive may synchronize with the AC load. As this will cause a drastic shortening of life should be verified with the actual machine.
Operate time	a) Operate time b) Release time c) Bounce time d) Switching frequency	1) It is beneficial to make the bounce time short for sound circuits and similar applications.
Mechanical characteristics	a) Vibration resistance b) Shock resistance c) Ambient temperature d) Life	1) Give consideration to performance under vibration and shock in the use location. 2) In particular, when used in high temperature applications, relay with class B or class F coil insulation may be required.
Other items	a) Mounting method b) Cover c) Size	1) Selection can be made for connection method with plug-in type, printed circuit board type, soldering, tab terminals, and screw fastening type. 2) For use in an adverse atmosphere, sealed construction type should be selected. 3) Are there any special conditions?

BASICS ON RELAY HANDLING

- To maintain initial performance, care should be taken to avoid dropping or hitting the relay.
- Under normal use, the relay is designed so that the case will not detach. To maintain initial performance, the case should not be removed. Relay characteristics cannot be guaranteed if the case is removed.
- Use of the relay in an atmosphere at standard temperature and humidity with minimal amounts of dust, SO₂, H₂S, or organic gases is recommended.
- Please avoid the use of silicon-based resins near the relay, because doing so may result in contact failure. (This applies to plastic sealed type relays, too.)
- Care should be taken to observe correct

coil polarity (+, -) for polarized relays.

- Proper usage requires that the rated voltage be impressed on the coil. Use rectangular waves for DC coils and sine waves for AC coils.
- Be sure the coil impressed voltage does not continuously exceed the maximum allowable voltage.
- Absolutely avoid using switching voltages and currents that exceed the designated values.
- The rated switching power and life are given only as guides. The physical phenomena at the contacts and contact life greatly vary depending on the type of load and the operating conditions. Therefore, be sure to carefully check the type of load and operating conditions

before use.

- Do not exceed the usable ambient temperature values listed in the catalog.
- Use the flux-resistant type or sealed type if automatic soldering is to be used.
- Use alcohol based cleaning solvents when cleaning is to be performed using a sealed type relay.
- Avoid ultrasonic cleaning of all types of relays.
- Avoid bending terminals, because it may cause malfunction.
- As a guide, use a Faston mounting pressure of 40 to 70N {4 to 7kgf} for relays with tab terminals.
- For proper use, read the main text for details.

PROBLEM POINTS WITH REGARD TO USE

In the actual use of relays, various ambient conditions are encountered, and because unforeseen events occur which can not be thought of on the drawing board, with regard to such conditions,

tests are necessary under the possible range of operation. For example, consideration must always be given to variation of performance when relay characteristics are being reviewed. The

relay is a mass production item, and as a matter of principle, it must be recognized that the relay is to be used to the extent of such variations without the need for adjustment.

RELAY COIL

• AC operation type

For the operation of AC relays, the power source is almost always a commercial frequency (50 or 60Hz) with standard voltages of 6, 12, 24, 48, 115, and 240V AC. Because of this, when the voltage is other than the standard voltage, the product is a special order item, and the factors of price, delivery, and stability of characteristics may create inconveniences. To the extent that it is possible, the standard voltages should be selected.

Also, in the AC type, shading coil resistance loss, magnetic circuit eddy current loss, and hysteresis loss exist, and because of lower coil efficiency, it is normal for the temperature rise to be greater than that for the DC type. Furthermore, because humming occurs when below the pick-up voltage and when above the rated voltage, care is required with regard to power source voltage fluctuations.

For example, in the case of motor starting, if the power source voltage drops, and during the humming of the relay, if it reverts to the restored condition, the contacts suffer a burn damage and welding, with the occurrence of a false operation self-maintaining condition. For the AC type, there is an inrush current during the operation time (for the separated condition of the armature, the impedance is low and a current greater than rated current flows; for the adhered condition of the armature, the impedance is high and the rated value of current flows), and because of this, for the case of several relays being used in parallel connection, it is necessary to give consideration to power consumption.

• DC operation type

For the operation of DC relays, standards exist for power source voltage and current, with DC voltage standards set at 5, 6, 12, 24, 48, and 100V, but with regard to current, the values as expressed in catalogs in milliamperes of pick-up current.

However, because this value of pick-up current is nothing more than a guarantee of just barely moving the armature, the variation in energizing voltage and resistance values, and the increase in coil

resistance due to temperature rise, must be given consideration for the worst possible condition of relay operation, making it necessary to consider the current value as 1.5 to 2 times the pick-up current. Also, because of the extensive use of relays as limit devices in place of meters for both voltage and current, and because of the gradual increase or decrease of current impressed on the coil causing possible delay in movement of the contacts, there is the possibility that the designated control capacity may not be satisfied. Thus it is necessary to exercise care. The DC type relay coil resistance varies due to ambient temperature as well as to its own heat generation to the extent of about 0.4%/°C, and accordingly, if the temperature increases, because of the increase in pick-up and drop-out voltages, care is required.

• Energizing voltage of AC coil

In order to have stable operation of the relay, the energizing voltage should be basically within the range of +10%/-15% of the rated voltage. However, it is necessary that the waveform on the coil be a sine wave. There is no problem if the power source is commercially provided power, but when a stabilized AC power source is used, there is a waveform distortion due to that equipment, and there is the possibility of abnormal overheating. By means of a shading coil for the AC coil,

humming is stopped, but with a distorted waveform, that function is not displayed. Fig. 1 below shows an example of waveform distortion.

If the power source for the relay operating circuit is connected to the same line as motors, solenoids, transformers, and other loads, when these loads operate, the line voltage drops, and because of this the relay contacts suffer the effect of vibration and subsequent burn damage. In particular, if a small type transformer is used and its capacity has no margin of safety, when there is long wiring, or in the case of household use or small sales shop use where the wiring is slender, it is necessary to take precautions because of the normal voltage fluctuations combined with these other factors. When trouble develops, a survey of the voltage situation should be made using a synchroscope or similar means, and the necessary counter-measures should be taken, and together with this determine whether a special relay with suitable excitation characteristics should be used, or make a change in the DC circuit as shown in Fig. 2 in which a capacitor is inserted to absorb the voltage fluctuations. In particular, when a magnetic switch is being used, because the load becomes like that of a motor, depending upon the application, separation of the operating circuit and power circuit should be tried and investigated.

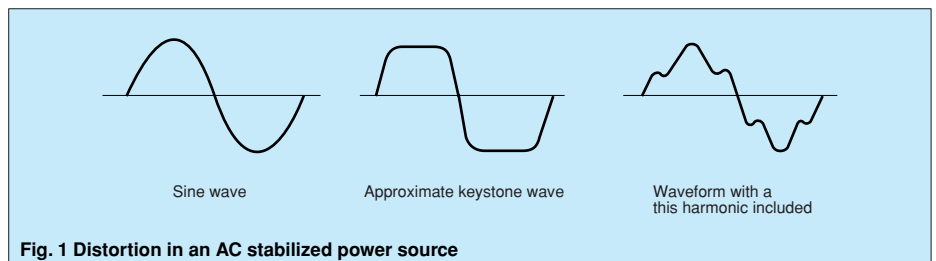

Fig. 1 Distortion in an AC stabilized power source

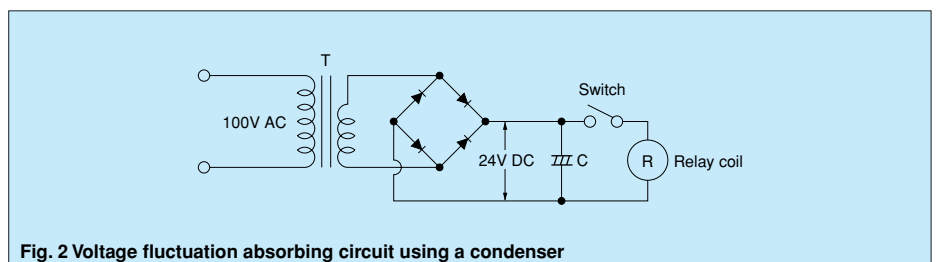

Fig. 2 Voltage fluctuation absorbing circuit using a condenser

General Application Guidelines

• Power source for DC input

As a power source for the DC type relay, a battery or either a half wave or full wave rectifier circuit with a smoothing capacitor is used. The characteristics with regard to the excitation voltage of the relay will change depending upon the type of power source, and because of this, in order to display stable characteristics, the most desirable method is perfect DC.

In the case of ripple included in the DC power source, particularly in the case of half wave rectifier circuit with a smoothing capacitor, if the capacity of the capacitor is too small, due to the influence of the ripple, humming develops and an unsatisfactory condition is produced. With the actual circuit to be used, it is absolutely necessary to confirm the characteristics. (Fig. 3)

With regard to our T-Series (TQ, TN, TK, TX, TX-D, TQ-SMD) and SEB relays, it is necessary to give consideration to the use of a power source with less than a 5% ripple, but for the J series, NC relays, there is no hindrance to the operation. However, the pull-up force becomes somewhat weakened, and it is necessary to take care since the resistance to vibration and shock is reduced. Also ordinarily the following must be given thought.

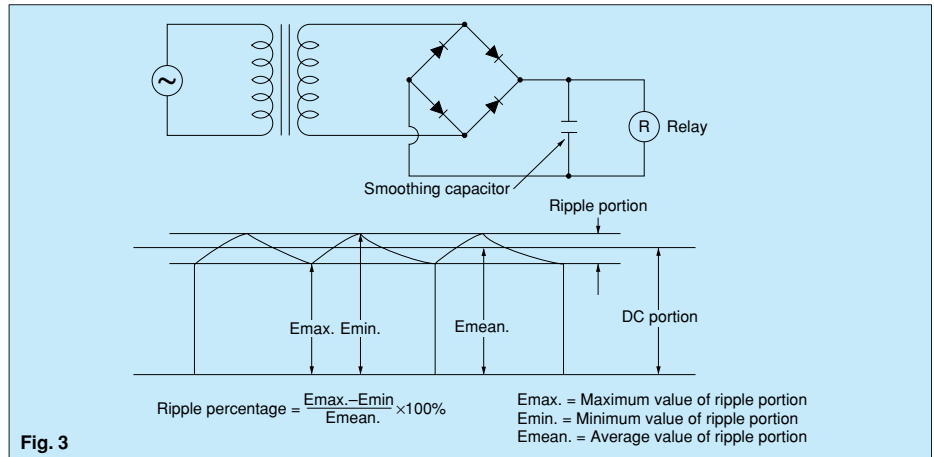

[1] It is desirable to have less than a 5% ripple for the reed type relay.

[2] For the hinge type relay, a half wave rectifier cannot be used, alone unless you use a smoothing capacitor. The ripple and the characteristics must be evaluated for proper usage.

[3] For the hinge type relay, there are certain applications that may or maynot use the full wave rectifier on it's own. Please check specifications with the original manufacture.

Shown on the right, is a circuit driven by the same power supply (battery, etc.) for both the coil and contact.

[4] Coil applied voltage and the drop in voltage.

Please verify that the actual voltage is applied to the coil at the actual load. Electrical life will be affected by the drop in voltage in the coil when load is turned on.

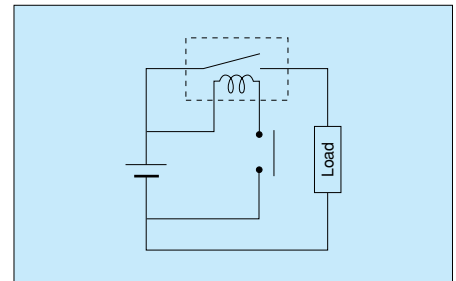

• Coil temperature rise

In addition to being a requirement for relay operation stability, the maximum continuous impressed coil voltage is an important constraint for the prevention of such problems as thermal deterioration or

deformity of the insulation material, or the occurrence of fire hazards.

In actual use with E-type insulation, when the ambient temperature is 40°C 104°F, a temperature rise limit of 80°C 176°F is thought to be reasonable according to the

resistance method. However, when complying with the Electrical Appliance and Material Safety Law, this becomes 75°C 167°F.

• Temperature rise due to pulse voltage

When a pulse voltage with ON time of less than 2 minutes is used, the coil temperature rise bares no relationship to the ON time. This varies with the ratio of ON time to OFF time, and compared with continuous current passage, it is rather small. The various relays are essentially the same in this respect. (Fig. 4)

Current passage time	%
For continuous passage	Temperature rise value is 100%
ON : OFF = 3 : 1	About 80%
ON : OFF = 1 : 1	About 50%
ON : OFF = 1 : 3	About 35%

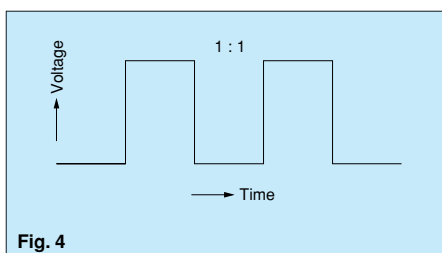

• Pick-up voltage change due to coil temperature rise (hot start)

In DC relays, after continuous passage of current in the coil, if the current is turned OFF, then immediately turned ON again, due to the temperature rise in the coil, the pick-up voltage will become somewhat higher. Also, it will be the same as using it in a higher temperature atmosphere. The resistance/temperature relationship for copper wire is about 0.4% for 1°C, and with this ratio the coil resistance increases. That is, in order to operate of the relay, it is necessary that the voltage be higher than the pick-up voltage and the pick-up voltage rises in accordance with the increase in the resistance value. However, for some polarized relays, this rate of change is considerably smaller.

• Operate time

In the case of AC operation, there is extensive variation in operate time depending upon the point in the phase at which the switch is turned ON for coil excitation, and it is expressed as a certain

range, but for miniature types it is for the most part 1/2 cycle (about 10ms).

However, for the somewhat large type relay where bounce is large, the operate time is 7 to 16ms, with release time in the order of 9 to 18ms Also, in the case of DC operation, to the extent of large coil input, the operating time is rapid, but if it is too rapid, the "A" contact bounce time is extended.

• Stray circuits (bypass circuits)

In the case of sequence circuit construction, because of bypass flow or alternate routing, it is necessary to take care not to have erroneous operation or abnormal operation. To understand this condition while preparing sequence circuits, as shown in Fig. 5, with 2 lines written as the power source lines, the upper line is always ⊕ and the lower line ⊖ (when the circuit is AC, the same thinking applies). Accordingly the ⊕ side is necessarily the side for making contact connections (contacts for relays, timers, limit switches, etc.), and the ⊖ side is the

load circuit side (relay coil, timer coil, magnet coil, solenoid coil, motor, lamp, etc.).

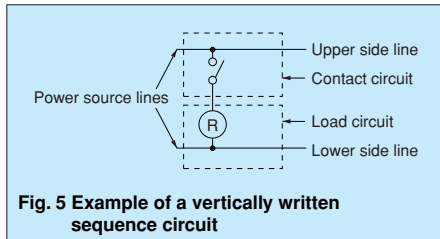

Fig. 5 Example of a vertically written sequence circuit

Fig. 6 shows an example of stray circuits. In Fig. 6 (a), with contacts A, B, and C closed, after relays R₁, R₂, and R₃ operate, if contacts B and C open, there is

a series circuit through A, R₁, R₂, and R₃, and the relays will hum and sometimes not be restored to the drop out condition. The connections shown in Fig. 6 (b) are

correctly made. In addition, with regard to the DC circuit, because it is simple by means of a diode to prevent stray circuits, proper application should be made.

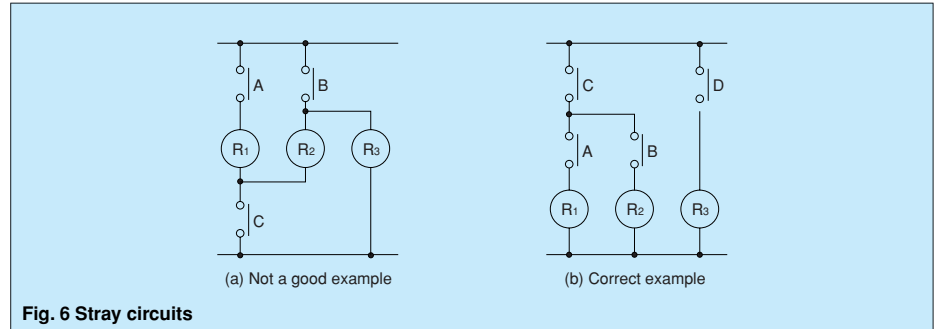

Fig. 6 Stray circuits

• Gradual increase of coil impressed voltage and suicide circuit

When the voltage impressed on the coil is increased slowly, the relay transferring operation is unstable, the contact pressure drops, contact bounce increases, and an unstable condition of contact occurs. This method of applying voltage to the coil should not be used, and consideration should be given to the method of impressing voltage on the coil (use of switching circuit). Also, in the case of latching relays, using self contacts "B," the method of self coil circuit for complete interruption is used, but because of the possibility of trouble developing, care should be taken.

The circuit shown in Fig. 7 causes a timing and sequential operation using a reed type relay, but this is not a good example

with mixture of gradual increase of impressed voltage for the coil and a suicide circuit. In the timing portion for relay R₁, when the timing times out, chattering occurs causing trouble. In the

initial test (trial production), it shows favorable operation, but as the number of operations increases, contact blackening (carbonization) plus the chattering of the relay creates instability in performance.

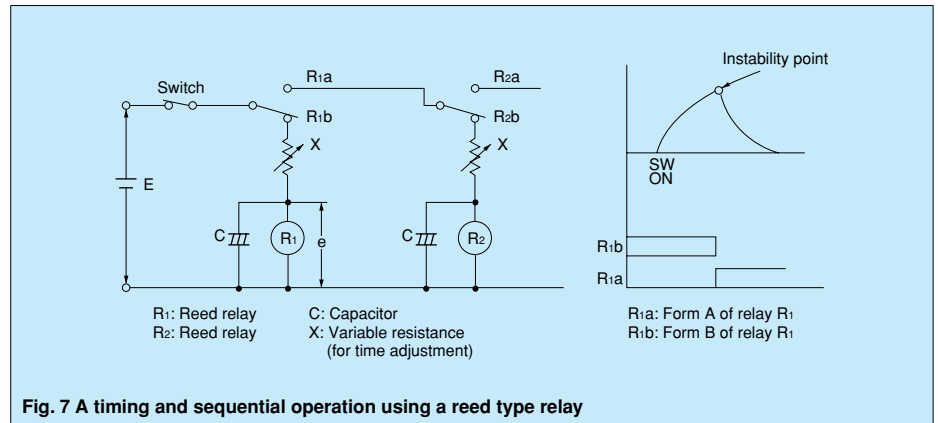

Fig. 7 A timing and sequential operation using a reed type relay

• Phase synchronization in AC load switching

If switching of the relay contacts is synchronized with the phase of the AC power, reduced electrical life, welded contacts, or a locking phenomenon (incomplete release) due to contact material transfer may occur. Therefore, check the relay while it is operating in the actual system. When driving relays with timers, micro computers and thyristors, etc., there may be synchronization with the power supply phase. (Fig. 8)

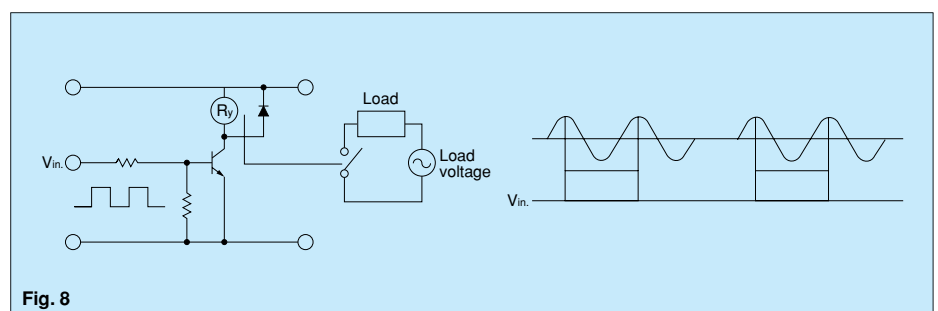

Fig. 8

• Erroneous operation due to inductive interference

For long wire runs, when the line for the control circuit and the line for power line use a single conduit, induction voltage, caused by induction from the power line, will be applied to the operation coil regardless of whether or not the control signal is off. In this case the relay and timer may not revert. Therefore, when wiring spans a long distance please remember that along with inductive interference, connection failure may be

caused by a problem with distribution capacity or the device might break down due to the influence of externally caused surges, such as that caused by lightning.

• Long term current carrying

A circuit designed for non-excitation when left running is desirable for circuits (circuits for emergency lamps, alarm devices and error inspection that, for example, revert only during malfunction and output warnings with form B contacts) that will be carrying a current continuously for long periods without relay switching

operation.

Continuous, long-term current to the coil will facilitate deterioration of coil insulation and characteristics due to heating of the coil itself.

For circuits such as these, please use a magnetic-hold type latching relay. If you must use a single stable relay, use a sealed type relay that is not easily affected by ambient conditions and provide a failsafe circuit design that considers the possibility of contact failure or disconnection.

General Application Guidelines

• Usage with infrequent switching

Please carry out periodic contact conductivity inspections when the frequency of switching is once or fewer times per month. When no switching of the contacts occurs for long periods, organic membrane may form on the contact surfaces and lead to contact instability.

• Regarding electrolytic corrosion of coils

In the case of comparatively high voltage coil circuits (in particular above 48 V DC), when such relays are used in high temperature and high humidity atmospheres or with continuous passage of current, the corrosion can be said to be the result of the occurrence of electrolytic corrosion. Because of the possibility of open circuits occurring, attention should be given to the following points.

[1] The ⊕ side of the power source should be connected to the chassis. (Refer to Fig. 9) (Common to all relays)

[2] In the case where unavoidably the ⊖ side is grounded, or in the case where grounding is not possible.

(1) Insert the contacts (or switch) in the ⊕ side of the power source, and connect the start of the coil winding the ⊖ side. (Refer to Fig. 10) (Common to all relays)

(2) When a grounding is not required, connect the ground terminal to the ⊕ side of the coil. (Refer to Fig. 11) (NF and NR with ground terminal)

[3] When the ⊖ side of the power source is grounded, always avoid interting the contacts (and switches) in the ⊖ side. (Refer to Fig. 12) (Common to all relays)

[4] In the case of relays provided with a ground terminal, when the ground terminal is not considered effective, not making a connection to ground plays an

important role as a method for preventing electrolytic corrosion.

Note: The designation on the drawing indicates the insertion of insulation between the iron core and the chassis. In relays where a ground terminal is provided, the iron core can be grounded directly to the chassis, but in consideration of electrolytic corrosion, it is more expedient not to make the connection.

Judgement: Good (Fig. 9)

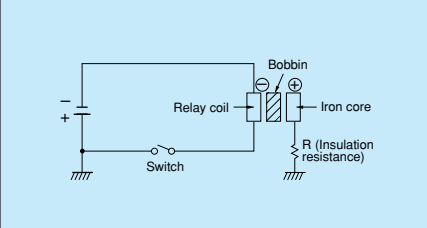

Judgement: Good (Fig. 11)

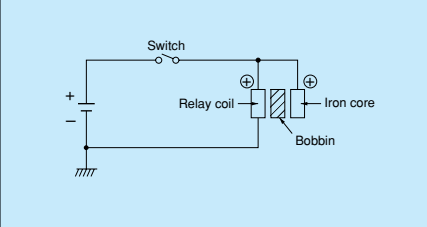

Judgement: Good (Fig. 10)

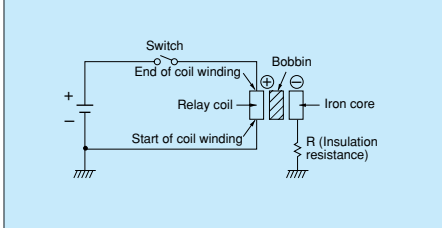

Judgement: No good (Fig. 12)

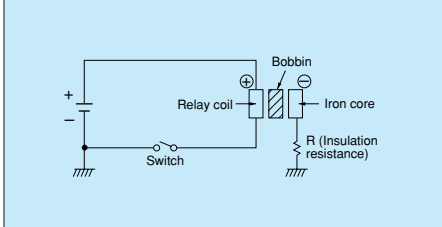

CONTACT

The contacts are the most important elements of relay construction. Contact performance conspicuously influenced by contact material, and voltage and current values applied to the contacts (in particular, the voltage and current waveforms at the time of application and release), the type of load, frequency of switching, ambient atmosphere, form of contact, contact switching speed, and of bounce.

Because of contact transfer, welding, abnormal wear, increase in contact resistance, and the various other damages which bring about unsuitable operation, the following items require full investigation.

*We recommend that you verify with one of our sales offices.

1. Contact circuit voltage, current, and load

[Voltage, AC and DC]

When there is inductance included in the circuit, a rather high counter emf is generated as a contact circuit voltage, and since, to the extent of the value of that voltage, the energy applied to the contacts causes damage with consequent wear of the contacts, and transfer of the contacts, it is necessary to

exercise care with regard to control capacity. In the case of DC, there is no zero current point such as there is with AC, and accordingly, once a cathode arc has been generated, because it is difficult to quench that arc, the extended time of the arc is a major cause. In addition, due to the direction of the current being fixed, the phenomenon of contact shift, as noted separately below, occurs in relation to the contact wear. Ordinarily, the approximate control capacity is mentioned in catalogs or similar data sheets, but this alone is not sufficient. With special contact circuits, for the individual case, the maker either estimates from the past experience or makes test on each occasion. Also, in catalogs and similar data sheets, the control capacity that is mentioned is limited to resistive load, but there is a broad meaning indicated for that class of relay, and ordinarily it is proper to think of current capacity as that for 125V AC circuits.

Minimum applicable loads are given in the catalog; however, these are only provided as a guide to the lower limit that the relay is able to switch and are not guaranteed values. The level of reliability of these values depends on switching frequency,

ambient conditions, change in the desired contact resistance, and the absolute value. Please use relays with AgPd contacts when minute analog load control or contact resistance no higher than 100 mΩ is desired (for measurement and wireless applications, etc.).

[Current]

The current at both the closing and opening time of the contact circuit exerts important influence. For example, when the load is either a motor or a lamp, to the extent of the inrush current at the time of closing the circuit, wear of the contacts, and the amount of contact transfer increase, and contact welding and contact transfer make contact separation impossible.

2. Characteristics of Common Contact Materials

Characteristics of contact materials are given below. Refer to them when selecting a relay.

Contact Material	Ag (silver)	Electrical conductivity and thermal conductivity are the highest of all metals. Exhibits low contact resistance, is inexpensive and widely used. A disadvantage is it easily develops a sulfide film in a sulfide atmosphere. Care is required at low voltage and low current levels.
	AgCd (silver-cadmium)	Exhibits the conductivity and low contact resistance of silver as well as excellent resistance to welding. Like silver, it easily develops a sulfide film in a sulfide atmosphere.
	AgW (silver-tungsten)	Hardness and melting point are high, arc resistance is excellent, and it is highly resistant to material transfer. However, high contact pressure is required. Furthermore, contact resistance is relatively high and resistance to corrosion is poor. Also, there are constraints on processing and mounting to contact springs.
	AgNi (silver-nickel)	Equals the electrical conductivity of silver. Excellent arc resistance.
	AgPd (silver-palladium)	At standard temperature, good corrosion resistance and good sulfidation resistance. However, in dry circuits, organic gases adhere and it easily develops a polymer. Gold clad is used to prevent polymer buildup. Expensive.
Surface Finish	Rh plating (rhodium)	Combines perfect corrosion resistance and hardness. As plated contacts, used for relatively light loads. In an organic gas atmosphere, care is required as polymers may develop. Therefore, it is used in hermetic seal relays (reed relays, etc.) . Expensive.
	Au clad (gold clad)	Au with its excellent corrosion resistance is pressure welded onto a base metal. Special characteristics are uniform thickness and the nonexistence of pinholes. Greatly effective especially for low level loads under relatively adverse atmospheres. Often difficult to implement clad contacts in existing relays due to design and installation.
	Au plating (gold plating)	Similar effect to Au cladding. Depending on the plating process used, supervision is important as there is the possibility of pinholes and cracks. Relatively easy to implement gold plating in existing relays.
	Au flash plating (gold thin-film plating)	Purpose is to protect the contact base metal during storage of the switch or device with built-in switch. However, a certain degree of contact stability can be obtained even when switching loads.

3. Contact Protection

• Counter EMF

When switching inductive loads with a DC relay such as relay sequence circuits, DC motors, DC clutches, and DC solenoids, it is always important to absorb surges (e.g. with a diode) to protect the contacts.

When these inductive loads are switched off, a counter emf of several hundred to several thousand volts develops which can severely damage contacts and greatly shorten life. If the current in these loads is relatively small at around 1A or less, the counter emf will cause the ignition of a glow or arc discharge. The discharge decomposes organic matter contained in the air and causes black deposits (oxides, carbides) to develop on the contacts. This may result in contact failure.

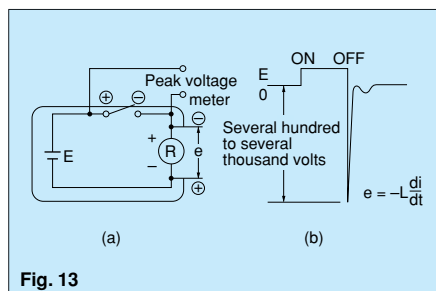

Fig. 13

In Fig. 13 (a), an emf ($e = -L \frac{di}{dt}$) with a steep waveform is generated across the coil with the polarity shown in Fig. 13 (b) at the instant the inductive load is switched off. The counter emf passes through the power supply line and reaches both contacts.

Generally, the critical dielectric breakdown voltage at standard temperature and pressure in air is about 200 to 300 volts. Therefore, if the counter emf exceeds this, discharge occurs at the contacts to dissipate the energy ($\frac{1}{2}Li^2$) stored in the coil. For this reason, it is desirable to absorb the counter emf so that it is 200V or less.

• Material Transfer Phenomenon

Material transfer of contacts occurs when one contact melts or boils and the contact material transfers to the other contact. As the number of switching operations increases, uneven contact surfaces develop such as those shown in Fig. 14. After a while, the uneven contacts lock as if they were welded together. This often occurs in circuits where sparks are produced at the moment the contacts "make" such as when the DC current is large for DC inductive or capacitive loads or when the inrush current is large (several amperes or several tens of amperes).

Contact protection circuits and contact materials resistant to material transfer such as AgSnO, AgW or AgCu are used as countermeasures. Generally, a concave formation appears on the cathode and a convex formation appears on the anode. For DC capacitive loads (several amperes to several tens of amperes), it is always necessary to conduct actual confirmation tests.

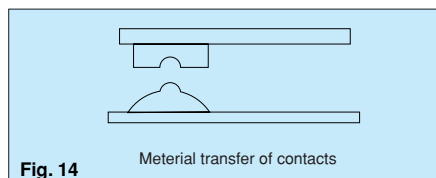

Fig. 14

General Application Guidelines

• Contact Protection Circuit

Use of contact protective devices or protection circuits can suppress the

counter emf to a low level. However, note that incorrect use will result in an adverse

effect. Typical contact protection circuits are given in the table below.

(G: Good NG: No Good)

Circuit	Application	Application		Features/Others	Devices Selection
		AC	DC		
CR circuit	Inductive load	*	G	If the load is a timer, leakage current flows through the CR circuit causing faulty operation. * If used with AC voltage, be sure the impedance of the load is sufficiently smaller than that of the CR circuit	As a guide in selecting r and c, r: 0.5 to 1Ω per 1V contact voltage c: 0.5 to 1μF per 1A contact current Values vary depending on the properties of the load and variations in relay characteristics. Capacitor c acts to suppress the discharge the moment the contacts open. Resistor r acts to limit the current when the power is turned on the next time. Test to confirm. Use a capacitor with a breakdown voltage of 200 to 300V. Use AC type capacitors (non-polarized) for AC circuits.
			G	G	
Diode circuit	Inductive load	NG	G	The diode connected in parallel causes the energy stored in the coil to flow to the coil in the form of current and dissipates it as joule heat at the resistance component of the inductive load. This circuit further delays the release time compared to the CR circuit. (2 to 5 times the release time listed in the catalog)	Use a diode with a reverse breakdown voltage at least 10 times the circuit voltage and a forward current at least as large as the load current. In electronic circuits where the circuit voltages are not so high, a diode can be used with a reverse breakdown voltage of about 2 to 3 times the power supply voltage.
Diode and zener diode circuit	Inductive load	NG	G	Effective when the release time in the diode circuit is too long.	Use a zener diode with a zener voltage about the same as the power supply voltage.
Varistor circuit	Inductive load	G	G	Using the stable voltage characteristics of the varistor, this circuit prevents excessively high voltages from being applied across the contacts. This circuit also slightly delays the release time. Effective when connected to both contacts if the power supply voltage is 24 or 48V and the voltage across the load is 100 to 200V.	—————

• Avoid using the protection circuits shown in the figures below.

Although DC inductive loads are usually more difficult to switch than resistive loads, use of the proper protection circuit will raise the characteristics to that for resistive loads. (Fig. 15)

Fig. 15

No good

No good

Although extremely effective in arc suppression as the contacts open, the contacts are susceptible to welding since energy is stored in C when the contacts open and discharge current flows from C when the contacts close.

Although extremely effective in arc suppression as the contacts open, the contacts are susceptible to welding since charging current flows to C when the contacts close.

• Mounting the Protective Device

In the actual circuit, it is necessary to locate the protective device (diode, resistor, capacitor, varistor, etc.) in the immediate vicinity of the load or contact. If located too far away, the effectiveness of the protective device may diminish. As a guide, the distance should be within 50cm.

• Abnormal Corrosion during High Frequency Switching of DC Loads (spark generation)

If, for example, a DC valve or clutch is switched at a high frequency, blue-green rust may develop. This occurs from the reaction of nitrogen and oxygen in the air when sparks (arc discharge) are generated during switching.

• Type of Load and Inrush Current

The type of load and its inrush current characteristics, together with the switching frequency, are important factors which cause contact welding. Particularly for loads with inrush currents, measure the steady state and inrush current. Then select a relay which provides an ample margin of safety. The table on the right shows the relationship between typical loads and their inrush currents. Also, verify the actual polarity used since, depending on the relay, electrical life is affected by the polarity of COM and NO.

Type of load	Inrush current
Resistive load	Steady state current
Solenoid load	10 to 20 times the steady state current
Motor load	5 to 10 times the steady state current
Incandescent lamp load	10 to 15 times the steady state current
Mercury lamp load	Approx. 3 times the steady state current
Sodium vapor lamp load	1 to 3 times the steady state current
Capacitive load	20 to 40 times the steady state current
Transformer load	5 to 15 times the steady state current

Load Inrush Current Wave and Time

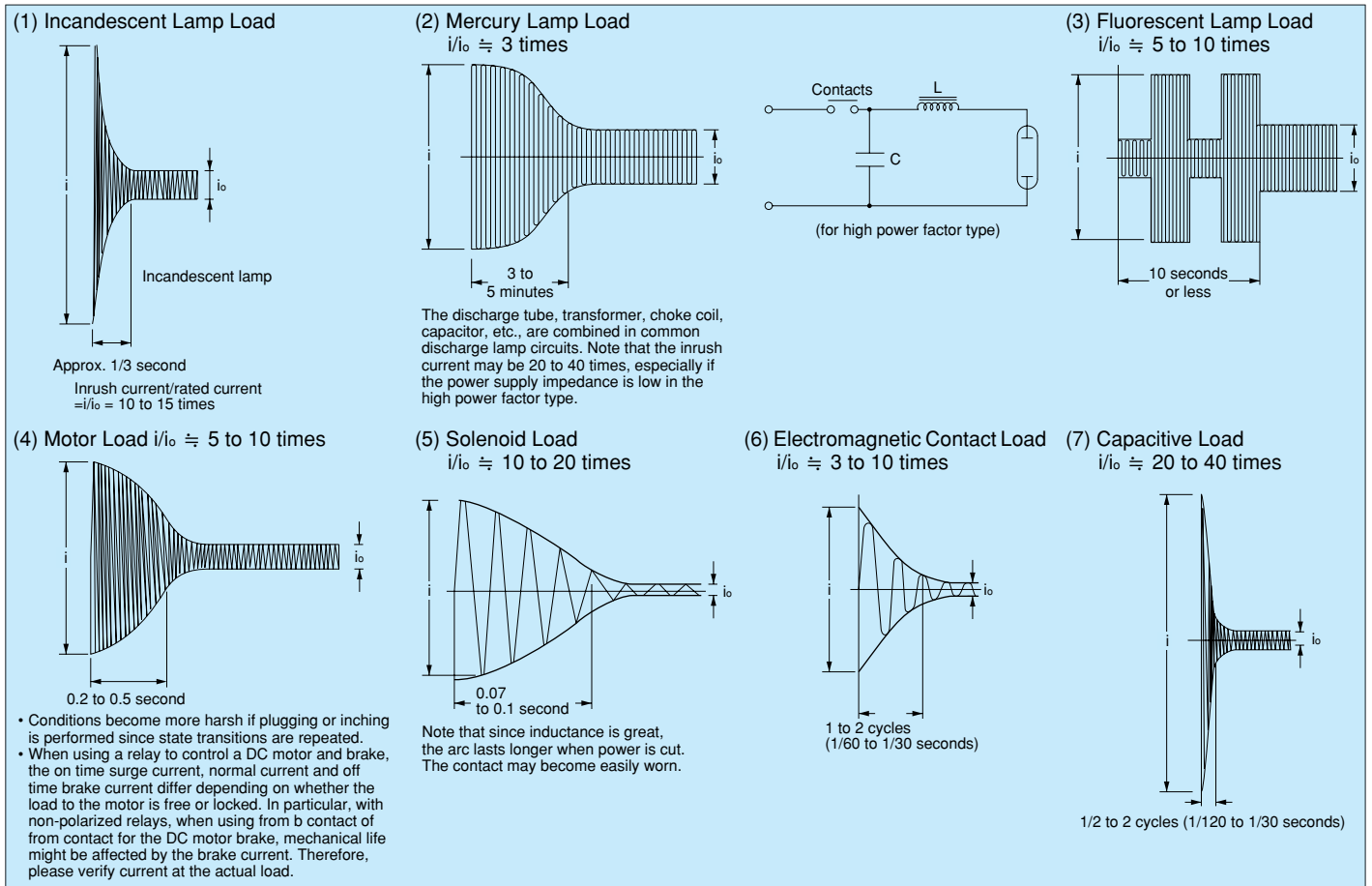

• When Using Long Wires

If long wires (100 to 300m) are to be used in a relay contact circuit, inrush current may become a problem due to the stray capacitance existing between wires. Add a resistor (approx. 10 to 50Ω) in series with the contacts. (Fig. 16)

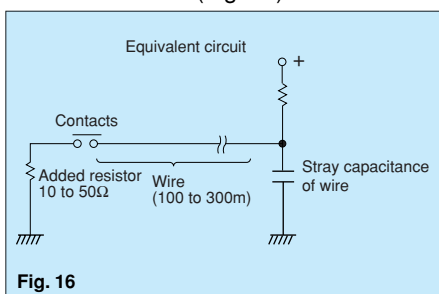

• Electrical life at high temperatures

Verify at the actual use condition since electrical life may be affected by use at high temperatures.

• Phase Synchronization in Switching AC Loads

If switching of the relay contacts is synchronized with the phase of the AC power, reduced electrical life, welded contacts, or a locking phenomenon (incomplete release) due to contact material transfer may occur. Therefore, check the relay while it is operating in the actual system. However, if problems develop, control the relay using an appropriate phase. (Fig. 17)

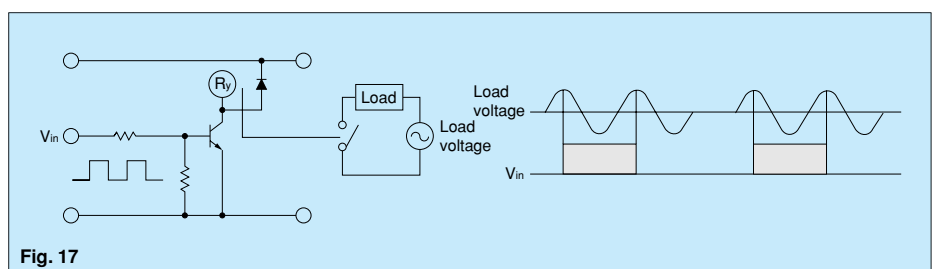

General Application Guidelines

4. Cautions on Use Related to Contacts

• Connection of load and contacts

Connect the load to one side of the power supply as shown in Fig. 18 (a). Connect the contacts to the other side. This prevents high voltages from developing between contacts. If contacts are connected to both side of the power supply as shown in Fig. 18 (b), there is a risk of shorting the power supply when relatively close contacts short.

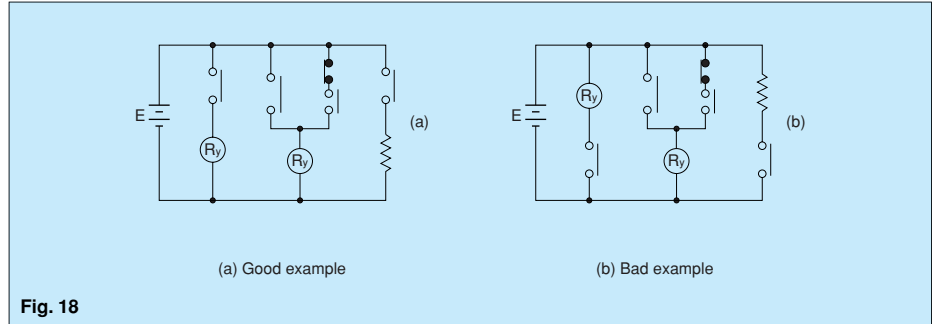

Fig. 18

• Dummy Resistor

Since voltage levels at the contacts used in low current circuits (dry circuits) are low, poor conduction is often the result. One method to increase reliability is to add a dummy resistor in parallel with the load to intentionally raise the load current reaching the contacts.

• Avoid Circuits Where Shorts Occur Between Form A and B Contacts (Fig. 19)

- 1) The clearance between form A and B contacts in compact control components is small. The occurrence of shorts due to arcing must be assumed.
- 2) Even if the three N.C., and COM contacts are connected so that they short, a circuit must never be designed to allow the possibility of burning or generating an overcurrent.
- 3) A forward and reverse motor rotation circuit using switching of form A and B contacts must never be designed.

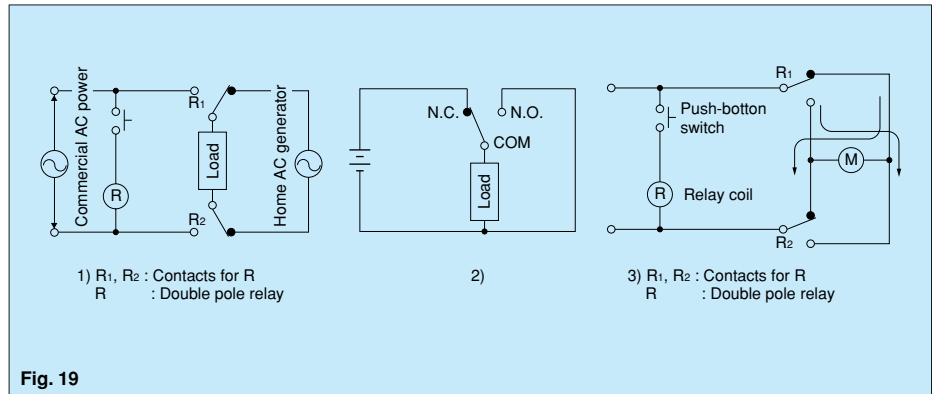

Fig. 19

• Shorts Between Different Electrodes

Although there is a tendency to select miniature control components because of the trend toward miniaturizing electrical control units, care must be taken when selecting the type of relay in circuits where different voltages are applied between electrodes in a multi-pole relay, especially when switching two different power supply

circuits. This is not a problem that can be determined from sequence circuit diagrams. The construction of the control component itself must be examined and sufficient margin of safety must be provided especially in creepage between electrodes, space distance, presence of barrier, etc.

LATCHING RELAYS

• Latching relays are shipped from the factory in the reset state. A shock to the relay during shipping or installation may cause it to change to the set state. Therefore, it is recommended that the relay be used in a circuit which initializes the relay to the required state (set or reset) whenever the power is turned on.

• Avoid impressing voltages to the set coil and reset coil at the same time.

• Connect a diode as shown since latching may be compromised when the relay is used in the following circuits.

If set coils or reset coils are to be connected together in parallel, connect a diode in series to each coil. Fig. 20 (a), Fig. 20 (b) Also, if the set coil of a relay and the reset coil of another relay are connected in parallel, connect a diode to the coils in series. Fig. 20 (c) If the set coil or reset coil is to be connected in parallel with an inductive load (e.g. another electromagnetic relay coil, motor, transformer, etc.), connect a diode to the set coil or reset coil in series. Fig. 20 (d)

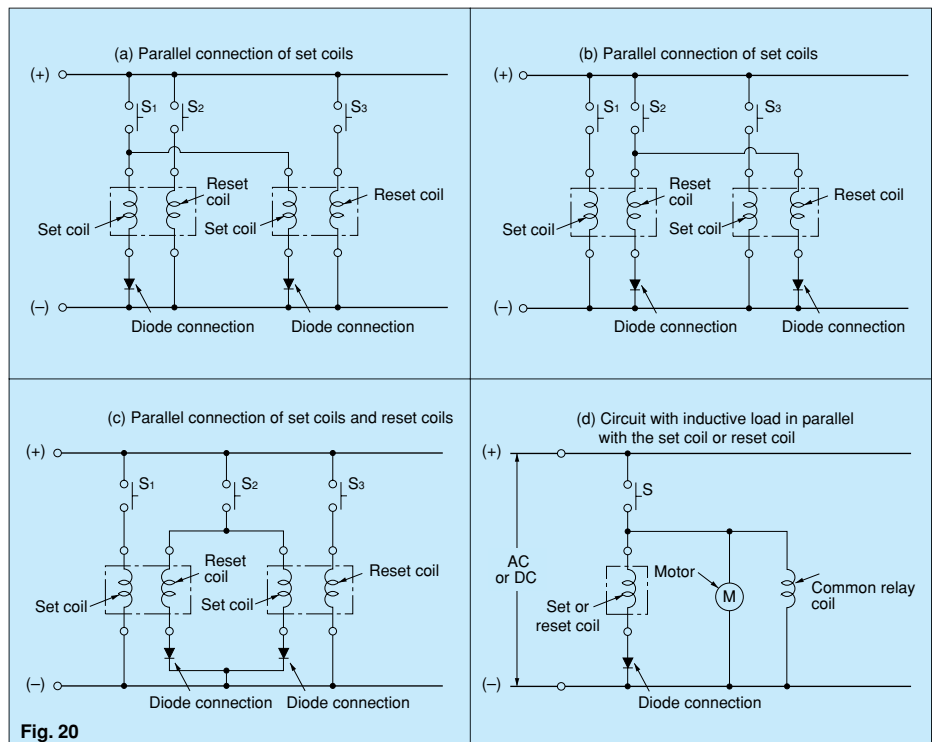
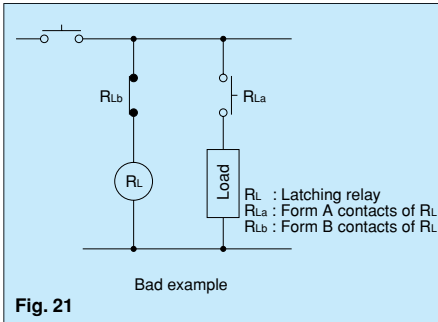

Fig. 20

Use a diode having an ample margin of safety for repeated DC reverse voltage and peak reverse voltage applications and having an average rectified current greater than or equal to the coil current.

- Avoid applications in which conditions include frequent surges to the power supply.
- Avoid using the following circuit since self-excitation at the contacts will inhibit the normal keep state. (Fig. 21)



• **Four-Terminal Latching Relay**
In the 2 coil latching type circuit in Fig. 22, one terminal at one end of the set coil and one terminal at one end of the reset coil are connected in common and voltages of the same polarity are applied to the other side for the set and reset operations. In this type of circuit, short 2 terminals of the relay as noted in the next table. This helps to keep the insulation high between the two winding.

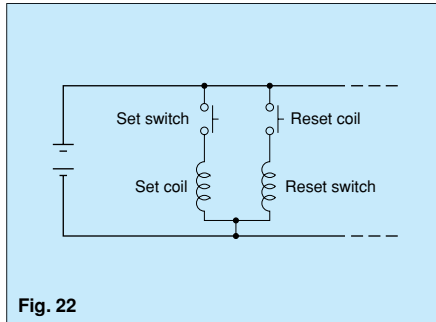

Relay Type	Terminal Nos.	
DS	1c	—
	2c	15 & 16
	4c	*
NC	Flat	5 & 6
	Slim	3 & 4
ST	*	
SP	2 & 4	
DE	1 & 2	
JH	6 & 8	

Notes:

1. *DS4c and ST relays are constructed so that the set coil and reset coil are separated for high insulation resistance.
2. DSP, TQ, TQ-SMD, TN, TX, and SEB relays are not applicable due to polarity.

• **Two Coil Latch Induction Voltage**
Each coil in a 2-coil latch relay is wound with a set coil and a reset coil on the same iron cores. Accordingly, induction voltage

is generated on the reverse side coil when voltage is applied and shut off to each coil. Although the amount of induction voltage is about the same as the rated relay

voltage, you must be careful of the reverse bias voltage when driving transistors.

HANDLING CAUTIONS FOR TUBE PACKAGING

Some types of relays are supplied in tube packaging. If you remove any relays from the tube packaging, be sure to slide the stop plug at one end to hold the remaining relays firmly together so they would not move in the tube. Failing to do this may lead to the appearance and/or performance being damaged.

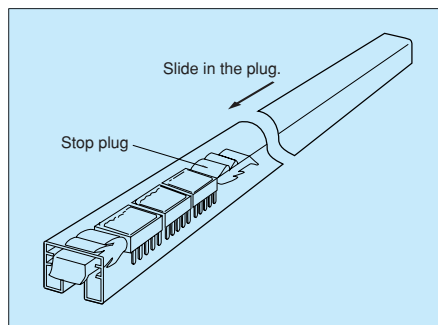

AMBIENT ENVIRONMENT

1. Ambient Temperature and Atmosphere

Be sure the ambient temperature at the installation does not exceed the value listed in the catalog. Furthermore, environmentally sealed types (plastic sealed type, metallic hermetic seal type) should be considered for applications in an atmosphere with dust, sulfur gases (SO₂, H₂S), or organic gases.

2. Silicon Atmosphere

Please use something other than silicon based materials (silicon rubber, silicon oil, silicon-based coatings, and silicon bulking agents, etc.) in the vicinity of the relay since their use will generate volatile gas. When contacts are switched in such an environment, silicon may adhere to the contacts and lead to contact failure (in plastic seal types, too).

3. NO_x Generation

When a plastic sealed type relay is used in an atmosphere high in humidity to switch a load which easily produces an arc, the NO_x created by the arc and the water absorbed from outside the relay combine to produce nitric acid. This corrodes the internal metal parts and adversely affects operation.

Avoid use at an ambient humidity of 85%RH or higher (at 20°C 68°F). If use at high humidity is unavoidable, consult us.

4. Vibration and Shock

If a relay and magnetic switch are mounted next to each other on a single plate, the relay contacts may separate momentarily from the shock produced when the magnetic switch is operated and result in faulty operation.

Countermeasures include mounting them

on separate plates, using a rubber sheet to absorb the shock, and changing the direction of the shock to a perpendicular angle.

5. Influence of External Magnetic Fields

Permanent magnets are used in reed relays and polarized relays (including NR relays), and their movable parts are constructed of ferrous materials. For this reason, when a magnet or permanent magnet in any other large relay, transformer, or speaker is located nearby, the relay characteristics may change and faulty operations may result. The influence depends on the strength of the magnetic field and it should be checked at the installation.

General Application Guidelines

6. Usage, storage, and transport conditions

1) During usage, storage, or transportation, avoid locations subject to direct sunlight and maintain normal temperature, humidity, and pressure conditions.

The allowable specifications for environments suitable for usage, storage, and transportation are given below.

- Temperature: The allowable temperature range differs for each relay, so refer to the relay's individual specifications.

In addition, when transporting or storing relays while they are tube packaged, there are cases when the temperature may differ from the allowable range.

In this situation, be sure to consult the individual specifications.

- Humidity: 5 to 85 % R.H.

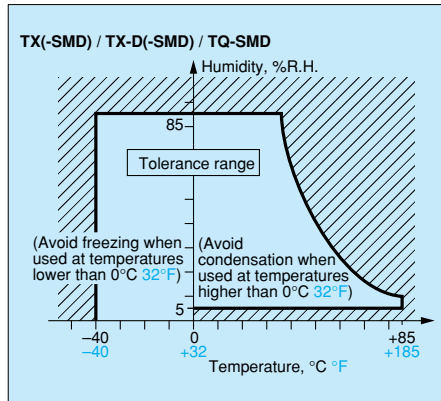

- Pressure: 86 to 106 kPa

The humidity range varies with the temperature. Use within the range indicated in the graph above.

2) Condensation

Condensation forms when there is a sudden change in temperature under high temperature, high humidity conditions.

Condensation will cause deterioration of the relay insulation.

3) Freezing

Condensation or other moisture may freeze on the relay when the temperatures is lower than 0°C 32°F.

This causes problems such as sticking of movable parts or operational time lags.

4) Low temperature, low humidity environments

The plastic becomes brittle if the relay is exposed to a low temperature, low humidity environment for long periods of time.

- Be aware that plastic may become brittle in low-temperature, low-humidity environments.

When stored in high-temperature, high-humidity environments, and in environments with organic or sulfide gases for long periods of time (including during transport), sulfide or oxide membrane will form on the surfaces of the contacts, which may lead to contact instability or malfunction, as well as

functional disorder. Please verify the environment for storing and transporting.

- Packaging should be designed to reduce, as much as possible, the influence of humidity, organic gas and sulfide gas when packaging.

- Since the SMD type is sensitive to humidity it is packaged with tightly sealed anti-humidity packaging. However, when storing, please be careful of the following.

(1) Please use promptly once the anti-humidity pack is opened. (As a guide, use within one week.)

(2) When storing for a long period after opening the anti-humidity pack, storage in a humidity-controlled desiccator or in anti-humidity packaging with an anti-humidity bag to which silica gel has been added, is recommended. (As a guide, storage can be for three months.)

7. Vibration, Impact and Pressure when Shipping

When shipping, if strong vibration, impact or heavy weight is applied to a device in which a relay is installed, functional damage may occur. Therefore, please package in a way, using shock absorbing material, etc., so that the allowable range for vibration and impact is not exceeded.

ENVIRONMENTALLY SEALED TYPE RELAYS

Sealed type relays are available. They are effective when problems arise during PC board mounting (e.g. automatic soldering and cleaning). They also, of course, feature excellent corrosion resistance. Note the cautions below regarding the features and use of environmentally

sealed type relays to avoid problems when using them in applications.

1. Operating Environment

Plastic sealed type relays are not suited for use in environments that especially require air tightness. Although there is no problem if they are used at sea level,

avoid atmospheric pressures beyond 96±10kPa. Also avoid using them in an atmosphere containing flammable or explosive gases. Use the metallic hermetic seal types for these applications.

PROCESSING CONSIDERATIONS

1. Handling

State of the art relays are precision mechanical devices and as such are sensitive to abusive handling practices. Every attempt is made during their manufacture to preclude any anomalies. Relays are packed in a variety of ways to best protect them during shipment and subsequent handling. These include the use of "Egg Crate" type inserts which support the relay and prevent damage to the terminals, foam trays which prevent shock damage, and tubes similar to those used by semiconductor manufacturers for machine dispensing and assembly. During incoming inspection and subsequent customer handling operations, care should be taken so as not to degrade the device which has been

supplied in prime condition. Some key areas of concern:

(1) Terminals should not be handled in order to prevent contamination of the surface finish. This could lead to solderability problems.

(2) Terminal layout and P.C. board hole pattern should match. Any misalignment caused by mis-registered P.C. board holes can lead to severe stress on the relay, compromising performance and reliability (seal integrity).

(3) The storage temperature specification should be observed.

(4) Relays should be stored and handled in a suitably clean area.

2. Fluxing

Depending upon the type of relay involved, fluxing procedures should be

researched carefully. An unsealed relay is prone to internal flux contamination which can compromise contact performance, and ideally should be hand soldered.

"Flux-resistant" relays are available which will prevent flux migration through the terminal-header interface. These and "sealed" relays are compatible with mist foam or spray fluxing operations, however "Flux-resistant" types are not totally sealed which precludes washing operations, and makes a non-active flux almost a necessity.

Pre-heating the board assembly prior to soldering "Flux-resistant" types will dry the flux and further help to prevent flux being driven into the relay during the soldering operation.

3. Soldering

As with fluxing, automated soldering processes can, unless controlled carefully, compromise the performance of unsealed relays.

Flux-resistant and sealed types are compatible with mist dip or wave soldering procedures. Some state-of-the-art relays are suitable for various reflow processes, such as I.R. or vapor phase maximum soldering temperatures and times will vary from relay type to relay type, and

should not be exceeded. The use of an I.R. reflow process with a relay not specifically designed to withstand the process, will in all probability degrade the relay and cause performance problems. A safe practice would be to review the thermal profile of the process on a case by case basis with your local Matsushita office.

4. Cleaning

Any cleaning process which involves potential contamination of an unsealed

relay should be avoided. Sealed devices can be immersion cleaned in a suitable solvent (see solvent compatibility chart). Cleaning in a ultrasonic bath should also be avoided. A harmonic of the bath frequency may be induced in the contacts causing friction welding and subsequent contact sticking. Relays with a removable "vent" tab should be vented after cooling to room temperature following cleaning and drying.

MOUNTING CONSIDERATIONS

• Top View and Bottom View

Relays used for PC boards, especially the flat type relays, have their top or bottom surface indicated in the terminal wiring diagrams.

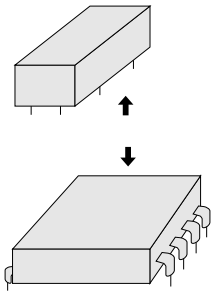

Relay with terminals viewed from the bottom (terminals cannot be seen from the top)

Relay with terminals viewed from the top (all terminals can be seen from the top)
Note during PC board pattern design (NL, NC)

• Mounting Direction

Mounting direction is important for optimum relay characteristics.

• Shock Resistance

It is ideal to mount the relay so that the movement of the contacts and movable parts is perpendicular to the direction of vibration or shock. Especially note that

the vibration and shock resistance of Form B contacts while the coil is not excited is greatly affected by the mounting direction of the relay.

• Contact Reliability

Mounting the relay so the surfaces of its contacts (fixed contacts or movable contacts) are vertical prevents dirt and dust as well as scattered contact material (produced due to large loads from which arcs are generated) and powdered metal from adhering to them.

Furthermore, it is not desirable to switch both a large load and a low level load with a single relay. The scattered contact material produced when switching the large load adheres to the contacts when switching the low level load and may cause contact failure. Therefore, avoid mounting the relay with its low level load contacts located below the large load contacts.

• Adjacent Mounting

When many relays are mounted close together, abnormally high temperatures may result from the combined heat generated. Mount relays with sufficient spacing between them to prevent heat

buildup.

This also applies when a large number of boards mounted with relays are installed as in a card rack. Be sure the ambient temperature of the relay does not exceed the value listed in the catalog.

• Influence of Adjacent Mounting of Polarized Relays

When polarized relays are mounted close together, their characteristics change. Since the affect of adjacent mounting differs according to the type of relay, refer to the data for the particular type.

• Panel Mounting

-Do not remove the panel. It has a special function. (It will not come off under normal handling.)

-When installing please use washers to prevent damage and deformation. Please keep the tightening torque to within 0.49 to 68.6 N (5 to 7 kgf). Also, please use a spring washer to prevent it from coming loose.

• Tab Terminals

As a guide, use a quick connect mounting pressure of 40 to 70N {4 to 7 kgf} for relays with tab terminals.

METHOD OF MOUNTING

• The direction of mounting is not specifically designated, but to the extent possible, the direction of contact movement should be such that vibration and shock will not be applied.

When a terminal socket is used

• After drilling the mounting holes, the terminal socket should be mounted making certain the mounting screws are not loose. DIN standard sockets are available for one-touch mounting on DIN rail of 35mm 1.378 inch width.

When reversible terminal sockets are used

• The reversible terminal sockets (HC, HL socket) are for one-touch mounting. (A panel thickness of 1 to 2mm .039 to .079 inch should be used.) (Fig. 23)

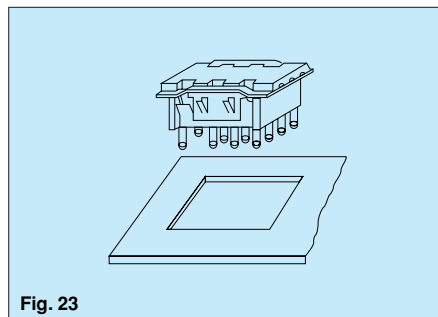

Fig. 23

• The socket should be pushed through the opening in the mounting panel until the projections on the side of the mounting bracket extend out over the back surface. (Fig. 24)

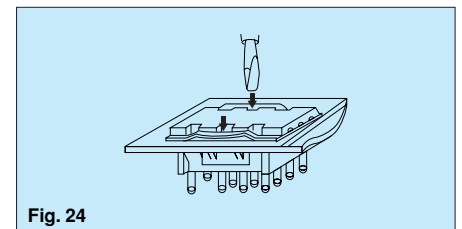

Fig. 24

• When all four of the projections are visible from the back side of the mounting panel, the mounting is completed and the socket is fastened.

• To remove the socket, the projections on the side of the mounting bracket should be pushed inward and at the same time the body of the socket should be pushed lightly from the back side. The socket can then be removed from the panel.

General Application Guidelines

REGARDING CONNECTION OF LEAD WIRES

• When making the connections, depending upon the size of load, the wire cross-section should be at least as large as the values shown in the table below.

Permissible current	Cross-section (mm ²)
2	0.2
3	0.3
5	0.5
7.5	0.75
12.5	1.25
15	2
20	2
30	3.5

• When the terminal board uses screw fastening connections, either pressure terminals or other means should be used to make secure fastening of the wire. To prevent damage and deformity, please use a torque within the following range when tightening the push screw block of the terminal block.

M4.5 screw:
1.47 to 1.666 N·m (15 to 17 kgf·cm)

M4 screw:
1.176 to 1.37 N·m (12 to 14 kgf·cm)

M3.5 screw:
0.784 to 0.98 N·m (8 to 10 kgf·cm)

M3 screw:
0.49 to 0.69 N·m (5 to 7 kgf·cm)

CAUTIONS FOR USE—Check List

	Check Item
Coil Drive Input	<ol style="list-style-type: none"> 1. Is the correct rated voltage applied? 2. Is the applied coil voltage within the allowable continuous voltage limit? 3. Is the ripple in the coil voltage within the allowable level? 4. For voltage applied to a polarized coil, is polarity observed? 5. When hot start is required, is the increase in coil resistance resulting from coil temperature rise taken into account in setting coil voltage? 6. Is the coil voltage free from momentary drop caused by load current? (Pay special attention for self-holding relays.) 7. Is supply voltage fluctuation taken into account when setting the rated coil voltage? 8. The relay status may become unstable if the coil voltage (current) is gradually increased or decreased. Was the relay tested in a real circuit or with a real load? 9. When driving with transistors, did you consider voltage drops?
Load (Relay contacts)	<ol style="list-style-type: none"> 1. Is the load rated within the contact ratings? 2. Does the load exceed the contacts' minimum switching capacity? 3. Special attention is required for contact welding when the load is a lamp, motor, solenoid, or electromagnetic contractor. 4. Was the relay tested with a real load? A DC load may cause contact lock-up due to large contact transfer. Was the relay tested with a real load? 5. For an inductive load, is a surge absorber used across the contacts? 6. When an inductive load causes heavy arc discharge across the relay contacts, the contacts may be corroded by chemical reaction with nitrogen in the atmosphere. Was the relay tested with a real load? 7. Platinum contacts may generate brown powder due to a catalyzer effect or vibration energy. Was the relay tested with a real load? 8. Is the contact switching frequency below the specification? 9. When there are more than two sets of contacts (2T) in a relay, metallic powder shed from one set of contacts may cause a contact failure on the other set (particularly for light loads). Was the relay tested in a real circuit? 10. A delay capacitor used across relay contacts may cause contact welding. Was the relay tested with a real load? 11. For an AC relay, a large contact bounce may cause contact welding. Was the relay tested in a real circuit or with a real load? 12. A high voltage may be induced at transformer load. Was the relay tested with a real load?
Circuit Design	<ol style="list-style-type: none"> 1. Does circuit design take into account electrolytic corrosion of the coil? 2. Are transistors and other circuit components protected from counter electromotive force that develops across the relay coil? 3. Is the circuit designed so the relay coil is left deenergized while the relay is inactive for long period of time? 4. Is the relay operated within the ratings approved by the relevant international standard (if compliance is required)? 5. Is the circuit protected from malfunction when the relay's activation and/or deactivation time varies considerably? 6. Is the circuit protected from malfunctions that might result from relay contact bounce? 7. Is the circuit protected from malfunction when a high-sensitivity self-holding relay, such as NR type, is to be used? 8. When there are two or more sets of contacts (2T) in a relay, arc discharges from load switching may cause short circuits across the two or more sets of contacts. Is the circuit designed to suppress such arc discharges? 9. Item 8 above also requires special attention when loads are supplied from separate power sources. 10. Does the post-installation insulation distance comply with the requirement of the relevant international standard or the Electrical Appliance and Material Control Law? 11. Is the circuit protected from malfunction when the relay is to be driven by transistors? 12. When the SCR is used for on/off control, the relay activation tends to synchronize with the line frequency, resulting in an extremely shortened life. Was the relay tested in a real circuit or with a real load? 13. Does the PC board design take into account use of on-board relay? 14. RF signals may leak across relay's open contacts. Check for adequate contact isolation and use RF relays as needed.

General Application Guidelines

	Check Item
Operating Environment	<ol style="list-style-type: none"> 1. Is the ambient temperature in the allowable operating temperature range? 2. Is relative humidity below 85 percent? 3. Is the operating atmosphere free from organic and sulfide gases? 4. Is the operating atmosphere free from silicon gas? Depending on the load type, silicon gas may cause a black substance to form on the contacts, leading to contact failure. 5. Is the operating atmosphere free from excessive airborne dust? 6. Is the relay protected from oil and water splashes? 7. Is the relay protected from vibration and impact which may cause poor contact with the socket? 8. Is ambient vibration and impact below the level allowable for the relay? 9. Is the relay free from mechanical resonance after it is installed in position? 10. Is insulation coating applied to the relay along with the PC board? Depending on the load type, a black substance may form to cause contact failure.
Installation and Connection	<ol style="list-style-type: none"> 1. Is the relay protected from solder chips and flux when it is manually soldered? 2. Are preparations for flux application and automatic soldering complete? 3. Is the PC board cleaning process designed to minimize adverse affects to the relays? 4. Are adequate separations provided between polarized or reed relays to prevent magnetic coupling? 5. Are the relay terminals free from stress in the socket? 6. Polarized relay's characteristics may be affected by strong external magnetic field. Are the relays installed away from such fields? 7. If very long leads (100 to 300 meters) are used to connect the load, the stray capacity existing across the leads may cause a surge current. Was the relay tested with a real load? 8. Unless otherwise specified, all relay terminals should be soldered at 250°C 482°F within 5 sec. or at 350°C 662°F within 3 sec. 9. A badly warped PC board can cause stress to the relay terminals which may lead to degraded relay characteristics. 10. Glass shot should not be used to clean the PC board of solder flux. This may cause relay malfunction due to glass powder becoming lodged in the relay's internal structure. 11. Relays should always be used with their plastic shields installed, or degraded relay performance may result. 12. Do not cut away any relay terminal as the stress may cause degraded relay performance.
Storage and Transport	<ol style="list-style-type: none"> 1. Is the relay subject to freezing or condensation (especially when shipping)? 2. Is the temperature in the allowable temperature range? 3. Is the humidity in the allowable humidity range? 4. Is the storing atmosphere free from organic and sulfide gases? 5. Is the storing atmosphere free from excessive airborne dust? 6. Is the relay protected from oil and water splashes? 7. Is the relay subject to the application of heavy weight? 8. When shipping does vibration and impact exceed the allowable range?

Reliability

• What is Reliability?

1. Reliability in a Narrow Sense of the Term

In the industrial world, reliability is an index of how long a particular product serves without failure.

2. Reliability in a Broad Sense of the Term

Every product has a finite service lifetime. This means that no product can continue normal service infinitely. When a product has broken down, the user may throw it away or repair it. The reliability of repairable products is recognized as “reliability in a broad sense of the term”. For repairable products, their serviceability or maintainability is another problem. In addition, reliability of product design is becoming a serious concern for the manufacturing industry. In short, reliability has three senses: i.e. reliability of the product itself, serviceability of the product, and reliability of product design.

3. Intrinsic Reliability and Reliability of Use

Reliability is “built” into products. This is referred to as intrinsic reliability which consists mainly of reliability in the narrow sense.

Product reliability at the user's site is called “reliability of use”, which consists mainly of reliability in the broad sense. In the relay industry, reliability of use has a significance in aspects of servicing.

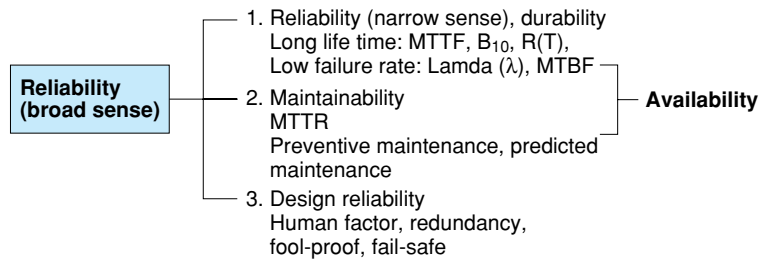

• Reliability Measures

The following list contains some of the most popular reliability measures:

Reliability measure	Sample representation
Degree of reliability R(T)	99.9%
MTBF	100 hours
MTTF	100 hours
Failure rate λ	20 fit, 1%/hour
Safe life B_{10}	50 hours

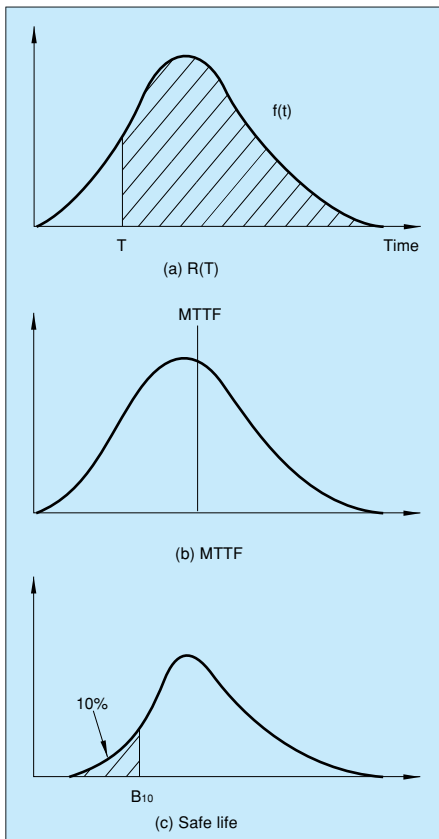

1. Degree of Reliability

Degree of reliability represents percentage ratio of reliability. For example, if none of 10 light bulbs has failed for 100 hours, the degree of reliability defined in, 100 hours of time is $10/10 = 100\%$. If only three bulbs remained alive, the degree of reliability is $3/10 = 30\%$.

The JIS Z8115 standard defines the degree of reliability as follows:

The probability at which a system, equipment, or part provides the specified functions over the intended duration under the specified conditions.

2. MTBF

MTBF is an acronym of mean time between failures. It indicates the mean time period in which a system, equipment, or part operates normally between two incidences of repair. MTBF only applies to repairable products.

MTBF tells how long a product can be used without the need for repair. Sometimes MTBF is used to represent the service lifetime before failure.

3. MTTF

MTTF is an acronym of mean time to failure. It indicates the mean time period until a product becomes faulty. MTTF normally applies to unrepairable products such as parts and materials.

The relay is one of such objective of MTTF.

4. Failure Rate

Failure rate includes mean failure rate and momentary failure rate. Mean failure rate is defined as follows:

Mean failure rate = Total failure count/total operating hours

In general, failure rate refers to momentary failure rate. This represents the probability at which a system, equipment, or part, which has continued normal operation to a certain point of time, becomes faulty in the subsequent specified time period.

Failure rate is often represented in the unit of percent/hours. For parts with low failure rates, “failure unit (Fit) = 10^9 /hour” is often used instead of failure rate. Percent/count is normally used for relays.

5. Safe Life

Safe life is an inverse of degree of reliability. It is given as value B which makes the following equation true:

$$1 - R(B) = t\%$$

In general, “ $B[1 - R(B)] = 10\%$ ” is more often used. In some cases this represents a more practical value of reliability than MTTF.

Reliability

• Failure

[1] What is Failure?

Failure is defined as a state of system, equipment, or component in which part of all of its functions are impaired or lost.

[2] Bathtub Curve

Product's failure rate throughout its lifetime is depicted as a bathtub curve, as shown below. Failure rate is high at the beginning and end of its service lifetime.

(I) Initial failure period

The high failure rate in the initial failure period is derived from latent design errors, process errors, and many other causes. Initial failures are screened at manufacturer's site through burn-in process. This process is called debugging, performing aging or screening.

(II) Accidental failure period

The initial failure period is followed by a long period with low, stable failure rate. In this period, called accidental failure period, failures occurs at random along the time axis. While zero accidental failure rate is desirable, this is actually not practical in the real world.

(III) Wear-out failure period

In the final stage of the product's service lifetime comes the wear-out failure period, in which the life of the product expires due to wear or fatigue. Preventive maintenance is effective for this type of failure. The timing of a relay's wear-out failure can be predicted with a certain accuracy from the past record of uses. The use of a relay is intended only in the accidental failure period, and this period virtually represents the service lifetime of the relay.

[3] Weibull Analysis

Weibull analysis is often used for classifying a product's failure patterns and to determine its lifetime. Weibull distribution is expressed by the following equation:

$$f(t) = \frac{m}{\alpha} \left(\frac{t - \gamma}{\alpha} \right)^{m-1} \exp \left[- \left(\frac{t - \gamma}{\alpha} \right)^m \right]$$

where

- m : Figure parameter
- α : Measurement parameter
- γ : Position parameter

Weibull distribution can be adopted to the actual failure rate distribution if the three variables above are estimated.

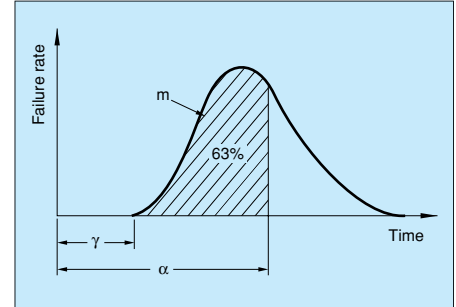

The Weibull probability chart is a simpler alternative of complex calculation formulas. The chart provides the following advantages:

- (1) The Weibull distribution has the closest proximity to the actual failure rate distribution.
- (2) The Weibull probability chart is easy to use.
- (3) Different types of failures can be identified on the chart.

The following describes the correlation with the bathtub curve. The value of the parameter "m" represents the type of the failure.

- (1) When $m < 1$: Initial failures
- (2) When $m = 1$: Accidental failures
- (3) When $m > 1$: Wear-out failures

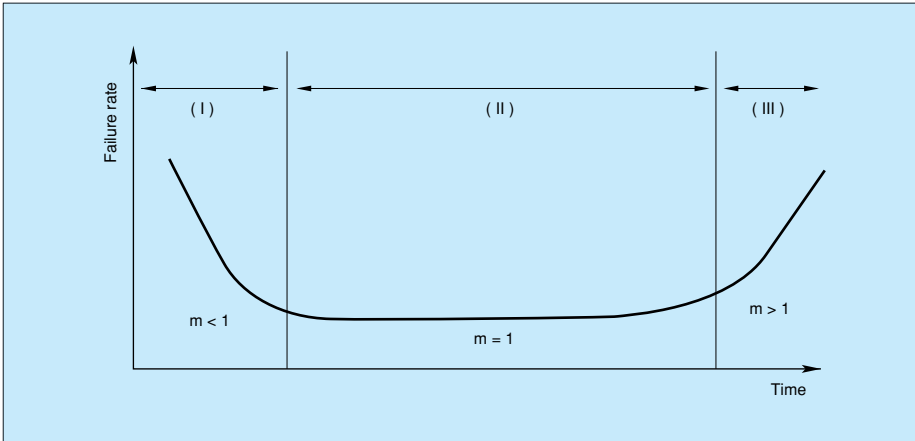

Applications of Relays in Electronic Circuits

RELAY DRIVE BY MEANS OF A TRANSISTOR

• Connection method

The voltage impressed on the relay is always full rated voltage, and in the OFF time, the voltage is completely zero for avoidance of trouble in use. (Fig. 1)

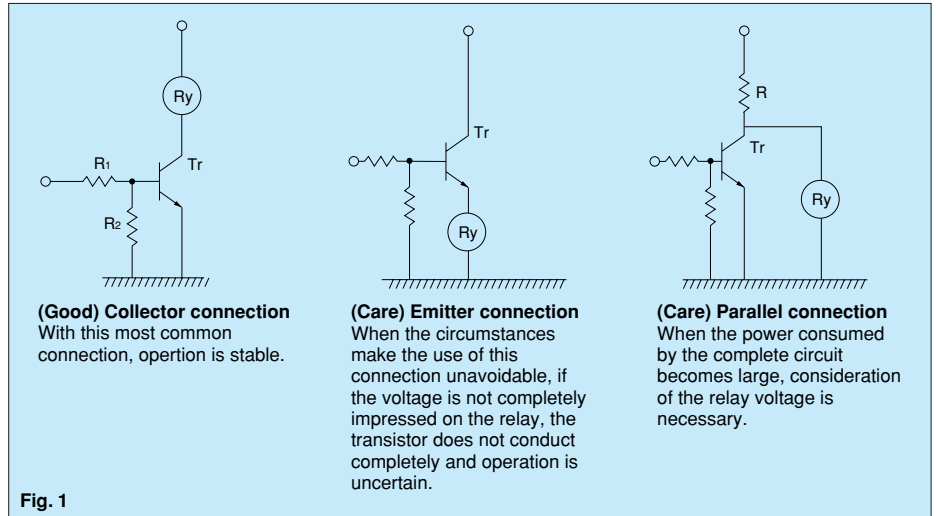

• Countermeasures for surge voltage of relay control transistor

If the coil current is suddenly interrupted, a sudden high voltage pulse is developed in the coil. If this voltage exceeds the voltage resistance of the transistor, the transistor will be degraded, and this will lead to damage. It is absolutely necessary to connect a diode in the circuit as a means of preventing damage from the counter emf.

As suitable ratings for this diode, the current should be equivalent to the average rectified current to the coil, and the inverse blocking voltage should be about 3 times the value of the power source voltage. (Fig. 2)

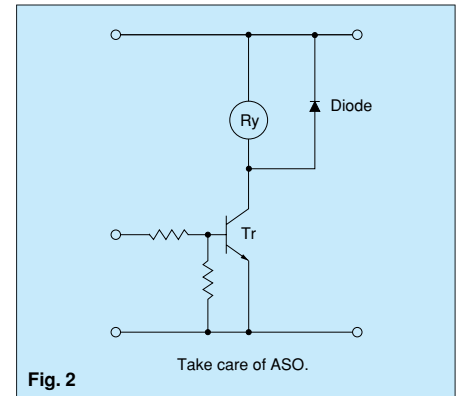

• Snap action

(Characteristic of relay with voltage rise and fall of voltage)

Unlike the characteristic when voltage is impressed slowly on the relay coil, this is the case where it is necessary to impress the rated voltage in a short time and also to drop the voltage in a short time. (Fig. 3)
As a guide, the rising time and falling time are 1 ms or less.

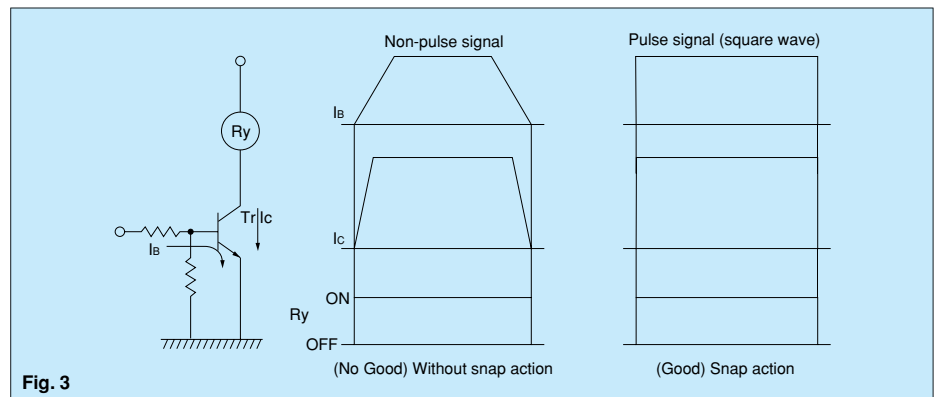

• Schmitt circuit (Snap action circuit)

(Wave rectifying circuit)

When the input signal does not produce a snap action, ordinarily a Schmitt trigger circuit is used to produce safe snap action.

Characteristic points

1. The common emitter resistor R_E must have a value sufficiently small compared with the resistance of the relay coil. (The voltage impressed on the relay must not be greater than the excitation voltage.)

2. Due to the relay coil current, the difference in the voltage at point P when T_2 is conducting and at point P when T_1 is conducting creates hysteresis in the detection capability of Schmitt circuit, and care must be taken in setting the values.

3. When there is chattering in the input signal because of waveform oscillation, an RC time constant circuit should be inserted in the stage before the Schmitt trigger circuit. (However, the response speed drops.) (Fig. 4)

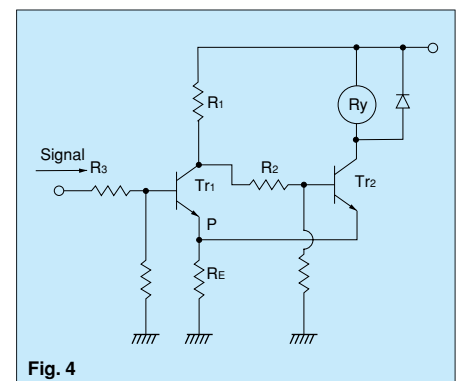

Applications of Relays in Electronic Circuits

• **Avoid Darlington circuit connections.**
(High amplification)
This circuit is a trap into which it is easy to fall when dealing with high circuit technology. This does not mean that it is immediately connected to the defect, but it is linked to troubles that occur after long periods of use and with many units in operation. (Fig. 5)

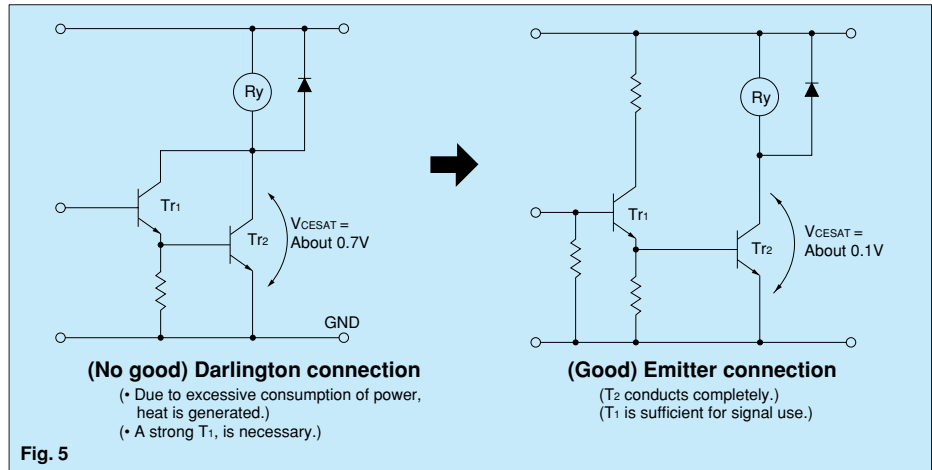

• **Residual Coil Voltage**
In switching applications where a semiconductor (transistor, UJT, etc.) is connected to the coil, a residual voltage is retained at the relay coil which may cause incomplete restoration and faulty operation. By using DC coils, there may be a reduction in; the danger of incomplete restoration, the contact pressure, and the vibration resistance. This is because the drop-out voltage is 10% or more of the rated voltage, a low

value compared to that for AC coil, and also there is a tendency to increase the life by lowering the drop-out voltage. When the signal from the transistor's collector is taken and used to drive another circuit as shown in the figure on the right, a minute dark current flows to the relay even if the transistor is off. This may cause the problems described above. (Fig. 6)

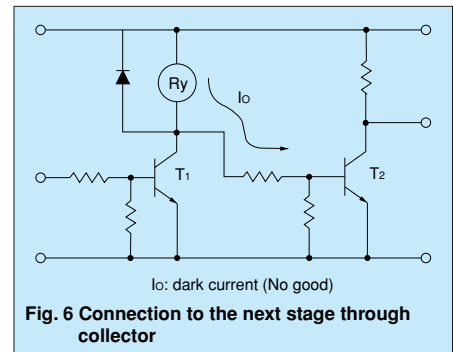

RELAY DRIVE BY MEANS OF SCR

• **Ordinary drive method**
For SCR drive, it is necessary to take particular care with regard to gate sensitivity and erroneous operation due to noise. (Fig. 7)

• **Caution points regarding ON/OFF control circuits**
(When used for temperature or similar control circuits)
When the relay contacts close simultaneously with an AC single phase power source, because the electrical life of the contacts suffers extreme shortening, care is necessary. (Fig. 8)
1. When the relay is turned ON and OFF using a SCR, the SCR serves as a half wave power source as it is, and there are ample cases where the SCR is easily restored.
2. In this manner the relay operation and restoration timing are easily synchronized with the power source frequency, and the timing of the load switching also is easily synchronized.
3. When the load for the temperature control is a high current load such as a

heater, the switching can occur only at peak values and it can occur only at zero phase values as a phenomenon of this type of control. (Depending upon the sensitivity and response speed of the relay)
4. Accordingly, either an extremely long life or an extremely short life results with wide variation, and it is necessary to take care with the initial device quality check.

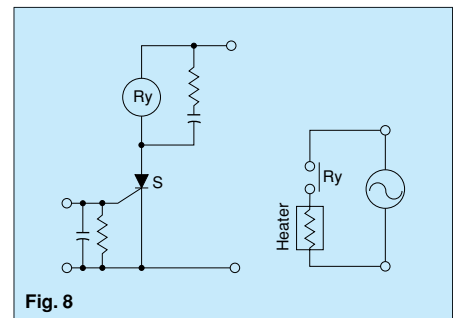
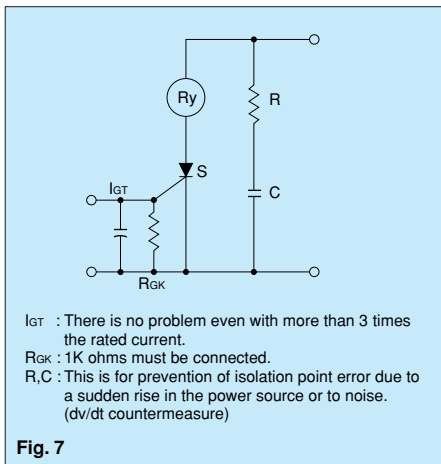

RELAY DRIVE FROM EXTERNAL CONTACTS

Relays for PC board use have high sensitivity and high speed response characteristics, and because they respond sufficiently to chattering and bouncing, it is necessary to take care in their drive.

When the frequency of use is low, with the delay in response time caused by a condenser, it is possible to absorb the chattering and bouncing. (Fig. 9)
(However, it is not possible to use only a condenser. A resistor should also be used with the capacitor.)

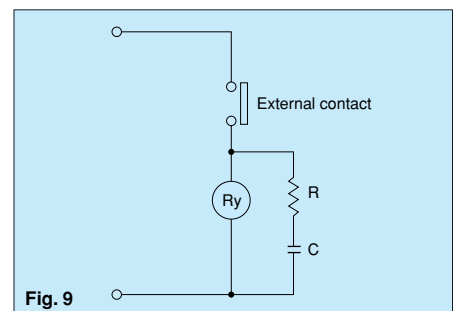

LED SERIES AND PARALLEL CONNECTIONS

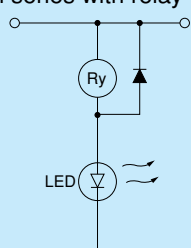
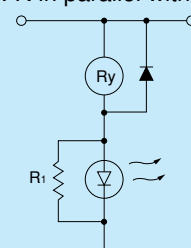
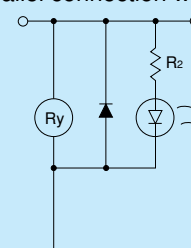
1. In series with relay	2. R in parallel with LED	3. In parallel connection with relay
		
<p>Power consumption: In common with relay (Good)</p> <p>Defective LED: Relay does not operate (No good)</p> <p>Low voltage circuit: With LED, 1.5V down (No good)</p> <p>No. of parts: (Good)</p>	<p>Power consumption: In common with relay (Good)</p> <p>Defective LED: Relay operate (No good)</p> <p>Low voltage circuit: With LED, 1.5V down (No good)</p> <p>No. of parts: R₁ (Care)</p>	<p>Power consumption: Current limiting resistor R₂ (Care)</p> <p>Defective LED: Relay operate stable (Good)</p> <p>Low voltage circuit: (Good)</p> <p>No. of parts: R₂ (Care)</p>

ELECTRONIC CIRCUIT DRIVE BY MEANS OF A RELAY

• Chatterless electronic circuit

Even though a chatterless characteristic is a feature of relays, this is to the fullest extent a chatterless electrical circuit, much the same as a mercury relay. To meet the requirement for such circuits as the input to a binary counter, there is an electronic chatterless method in which chattering is absolutely not permissible. Even if chattering develops on one side, either the N.O. side contacts or the N.C. side contacts, the flip flop does not reverse, and the counter circuit can be fed pulsed without a miss. (However, bouncing from the N.O. side to N.C. side must be absolutely avoided.) (Fig. 10)

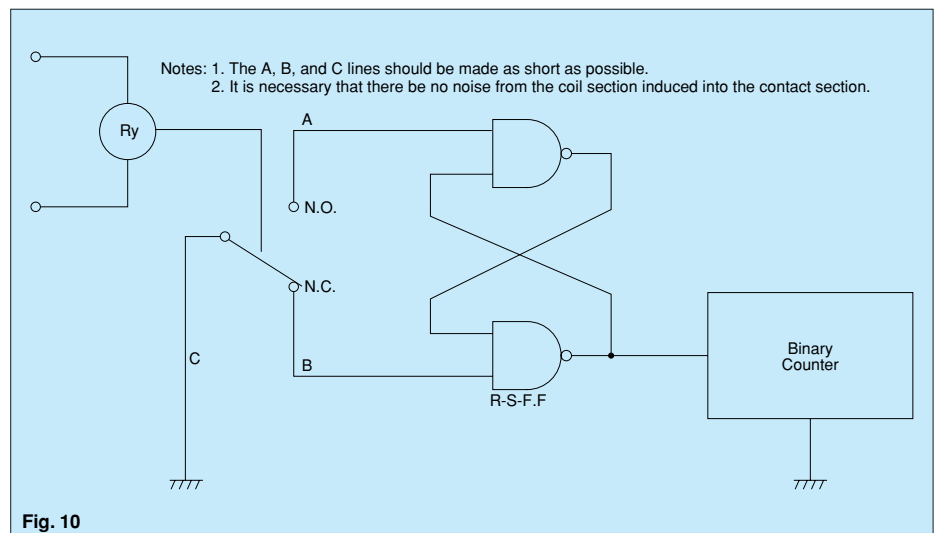

Fig. 10

• Triac drive

When an electronic circuit using a direct drive from a triac, the electronic circuit will not be isolated from the power circuit, and because of this, troubles due to erroneous operation and damage can develop easily. The introduction of a relay drive is the most economical and most effective solution. (Photo coupler and pulse transformer circuits are complicated.) When a zero cross switching characteristic is necessary, a solid state relay (SSR) should be used. (Fig. 11)

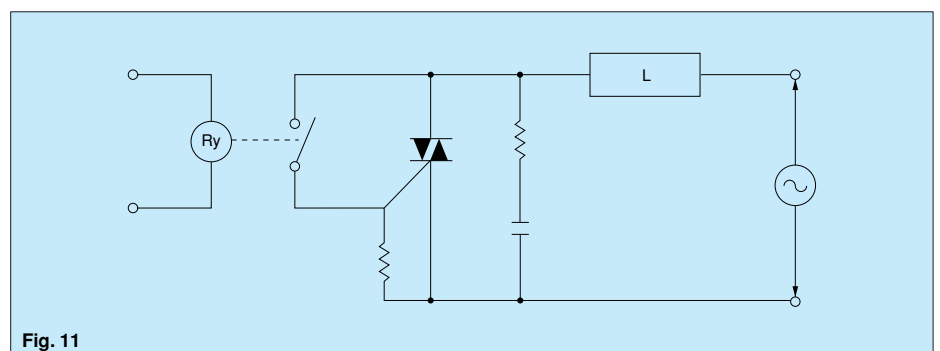

Fig. 11

Applications of Relays in Electronic Circuits

ASSURANCE OF POWER SOURCE FOR RELAY AND ELECTRONIC CIRCUIT

• Constant Voltage circuit and PC board pattern

Ordinarily, it is extremely undesirable to have ripple and voltage variation in an electronic circuit power source. This is naturally true also for relay power sources but not to the same extent as for the electronic circuit. Accordingly, it is desirable to have a constant voltage circuit for dedicated use of the electronic circuit with a sufficient margin of current. Roughly speaking, this is also good for the relay, but from a practical viewpoint, the relay should be operated within the standards set for ripple and voltage variation. Similarly, in the circuit diagram shown in Fig. 12, but means of the

manner in which the PC board pattern is designed, the ON/OFF operation of the relay coil, lamp, etc., will exert no

influence on the electronic circuit. This is just a matter of technique that is necessary.

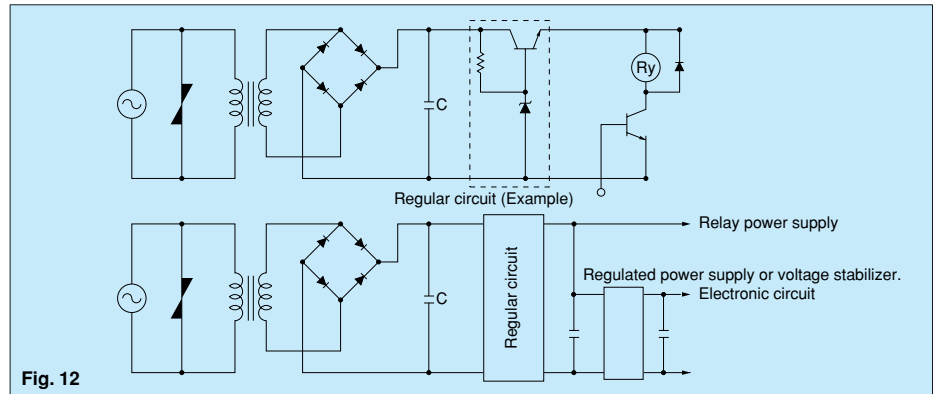

Fig. 12

• Prevention of Voltage Drop Due to Rush Current

In the circuit shown in Fig. 13 (a), rush current flows from the lamp or capacitor. The instant the contacts close, the voltage drops and the relay releases or chatters. In this case it is necessary to raise the transformer's capacity or add a smoothing circuit.

Fig. 13 (b) shows an example of the modified circuit.
Fig. 13 (c) shows a battery-powered version.

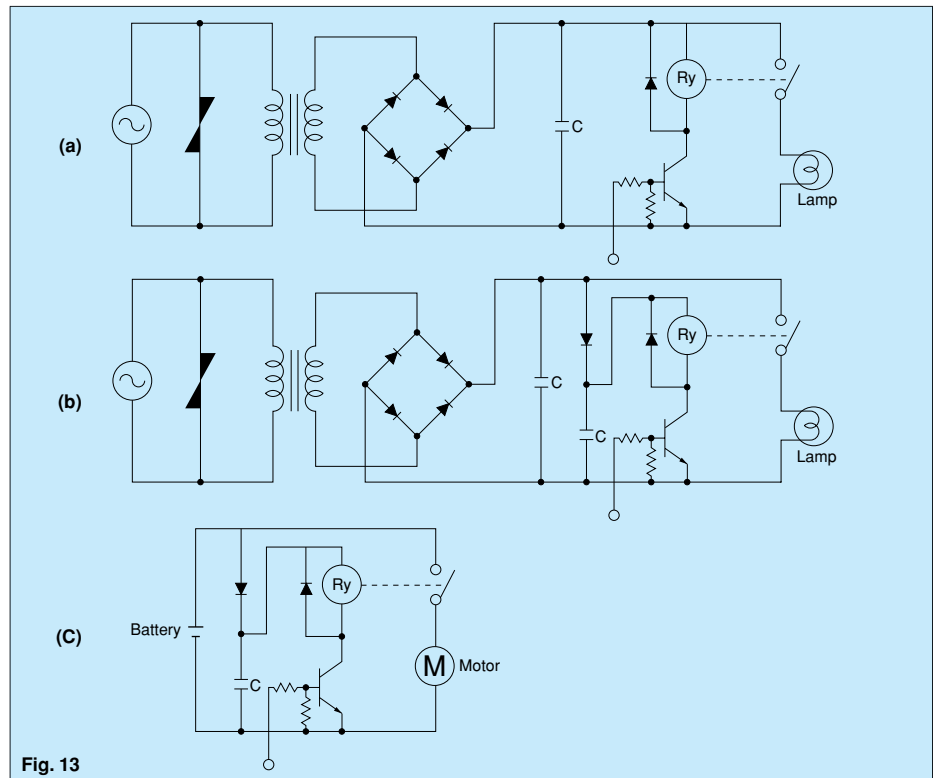

Fig. 13

PC BOARD DESIGN CONSIDERATIONS

• Pattern Layout for Relays

Since relays affect electronic circuits by generating noise, the following points should be noted.

Keep relays away from semiconductor devices. Design the pattern traces for shortest lengths. Place the surge arrester (diode, etc.) near the relay coil. Avoid routing pattern traces susceptible to noise (such as for audio signals) underneath the relay coil section. Avoid through-holes in places which cannot be seen from the top (e.g. at the base of the relay). Solder flowing up through such a hole may cause damage such as a broken seal. Even for

the same circuit, pattern design considerations which minimize the influence of the on/off operations of the

relay coil and lamp on other electronic circuits are necessary. (Fig. 14)

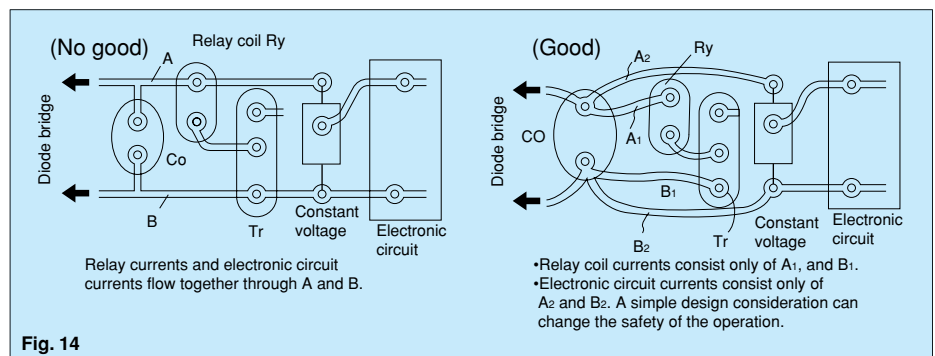

Fig. 14

Applications of Relays in Electronic Circuits

• When it is necessary to use hand soldering for one part of a component after dip soldering has been done

By providing a narrow slot in the circular part of the foil pattern, the slot will prevent the hole from being plugged with solder. (Fig. 15)

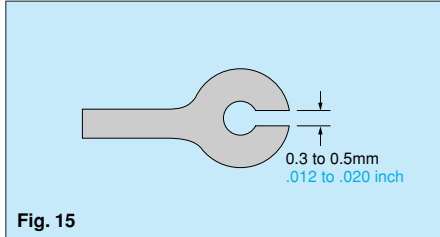

Fig. 15

• When the printed circuit board itself is used as a connector

[1] The edge should be beveled. (This prevents peeling of the foil when the board is inserted into its socket.)

[2] When only a single side is used as the connector blade, if there is distortion in the circuit board, contact will be defective. Care should be taken. (Fig. 16)

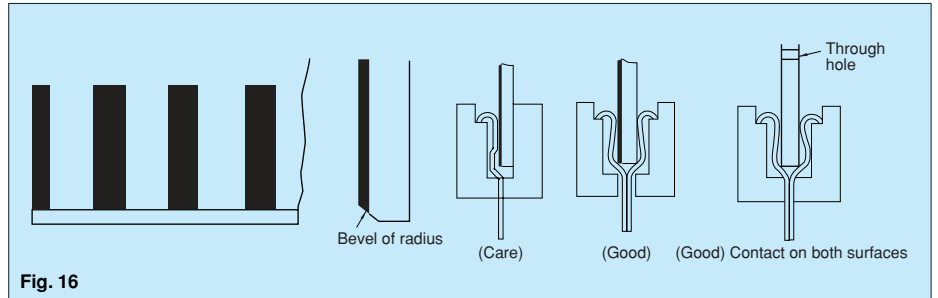

Fig. 16

PC BOARD REFERENCE DATA

(This data has been derived from samples of this company's products. Use this data as a reference when designing printed circuit boards.)

• Conductor width

The allowable current for the conductor was determined from the safety aspect and the effect on the performance of the conductor due to the rise in saturation temperature when current is flowing. (The narrower the conductor width and the thinner the copper foil, the larger the temperature rise.) For example, too high a rise in temperature causes degradation of

the characteristic and color changes of the laminate. In general, the allowable current capacity of the conductor is determined so that the rise in temperature is less than 10 degrees C. It is necessary to design the conductor width from this allowable conductor current capacity. Fig. 17, Fig. 18, Fig. 19 show the relationship between the current and the conductor

width for each rise in temperature for different copper foils. It is also necessary to give consideration to preventing abnormal currents from exceeding the destruction current of the conductor. Fig. 21 shows the relationship between the conductor width and the destruction current.

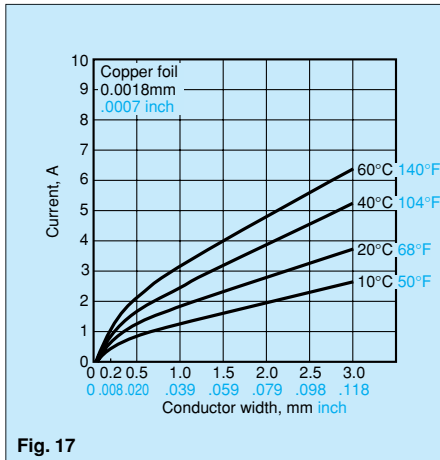

Fig. 17

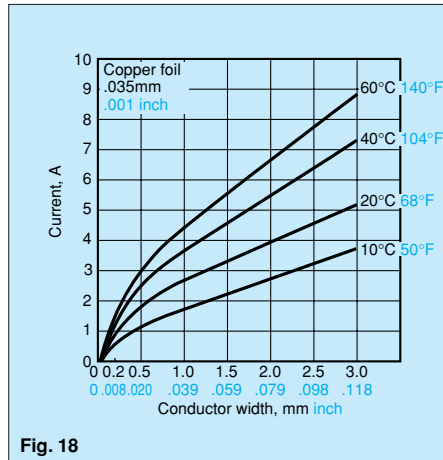

Fig. 18

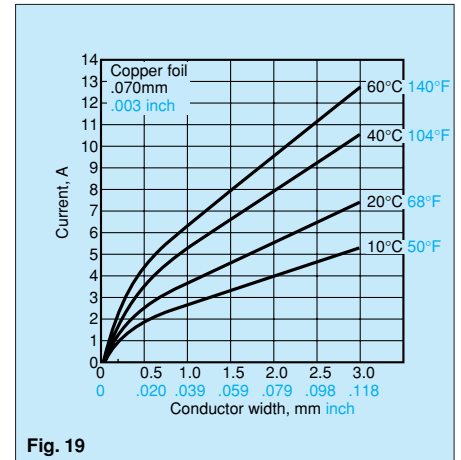

Fig. 19

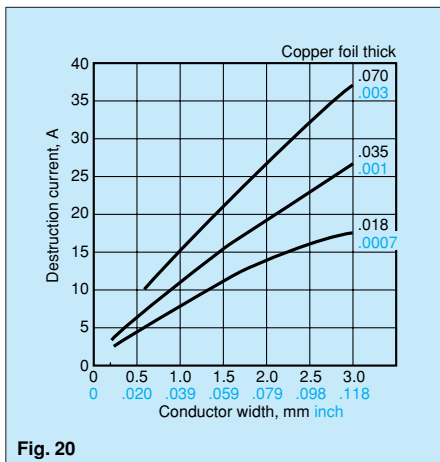

Fig. 20

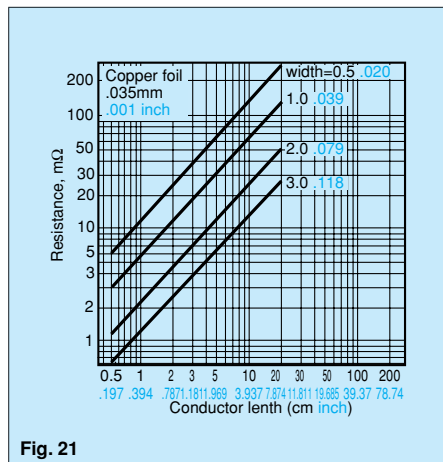

Fig. 21

Applications of Relays in Electronic Circuits

• Hole and land diameter

The hole diameter and land are made with the hole slightly larger than the lead wire so that the component may be inserted easily. Also, when soldering, the solder will build up in an eyelet condition, increasing the mounting strength.

The standard dimensions for the hole diameter and land are shown in the table below.

Standard dimensions for hole and land diameter

mm inch

Standard hole diameter	Tolerance	Land diameter
0.8 .031	±0.1 ±.039	2.0 to 3.0 .079 to .118
1.0 .039		
1.2 .047		3.5 to 4.5 .138 to .177
1.6 .063		

Remarks

1. The hole diameter is made 0.2 to 0.5mm **.008 to .020inch** larger than the lead diameter. However, if the jet method (wave type, jet type) of soldering is used, because of the fear of solder passing through to the component side, it is more suitable to make the hole diameter equal to the lead diameter +0.2mm.
2. The land diameter should be 2 to 3 times the hole diameter.
3. Do not put more than 1 lead in one hole.

• Expansion and shrinkage of copperclad laminates

Because copperclad laminates have a longitudinal and lateral direction, the manner of punching fabrication and layout must be observed with care. The expansion and shrinkage in the longitudinal direction due to heat is 1/15 to 1/2 that in the lateral, and accordingly, after the punching fabrication, the distortion in the longitudinal direction will be 1/15 to 1/2 that of the lateral direction. The mechanical strength in the longitudinal direction is 10 to 15% greater than that in the lateral direction. Because of this difference between the longitudinal and lateral directions, when products having long configurations are to be fabricated, the lengthwise direction of the configuration should be made in the longitudinal direction, and PC boards having a connector section should be made with the connector along the longitudinal side. (Fig. 22)

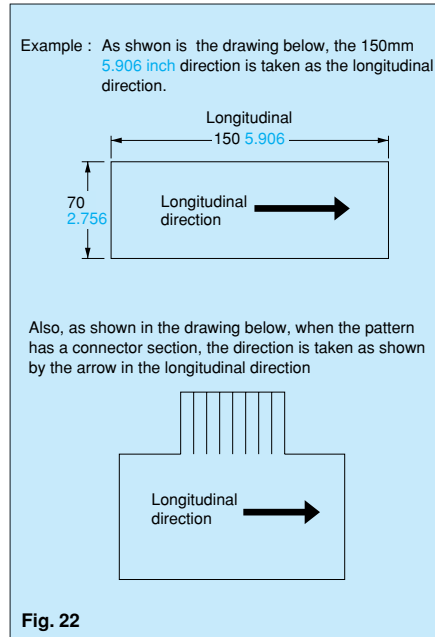

Space between conductors

Fig. 23 shows the relationship between the spacing between conductors and the destruction voltage. This destruction voltage is not the destruction voltage of the PCB; it is the flash over voltage (insulation breakdown voltage of the space between circuits.) Coating the surface of the conductor with an insulating resin such as a solder resist increases the flash over voltage, but because of the pin holes of the solder resist, it is necessary to consider the conductor destruction voltage without the solder resist. In fact, it is necessary to add an ample safety factor when determining the spacing between conductors. Table 1 shows an example of a design for the spacing between conductors. (Taken from the JIS C5010 standards.) However, when the product is covered by the electrical products control law, UL standards or other safety standards, it is necessary to conform to the regulations.

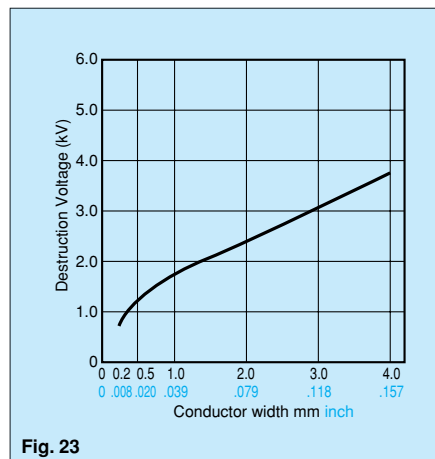
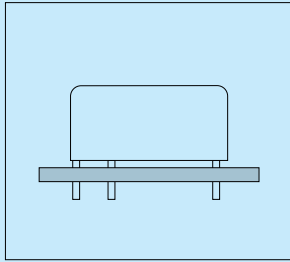

Table 1. Example of conductor spacing design

Maximum DC and AC Voltage Between Conductors (V)	Minimum Conductor Spacing (mm inch)
0 to 50	0.381 .015
51 to 150	0.635 .025
151 to 300	1.27 .050
301 to 500	2.54 .100
500 or more	Calculated at 0.00508 mm/V

Relay Soldering and Cleaning Guidelines

1. Mounting of Relay



- Avoid bending the terminals to make the relay self-clinching. Relay performance cannot be guaranteed if the terminals are bent. Self-clinching terminal types are available depending on the type of relay.
- Correctly drill the PC board according to the given PC board pattern illustration.
- Stick packaging for automatic mounting is available depending on the type of relay.

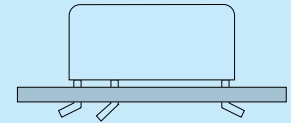

Bad example

2. Flux Application

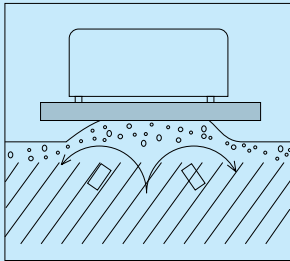

- Adjust the position of the PC board so that flux does not overflow onto the top of it. This must be observed especially for dust-cover type relays.
- Use rosin-based non-corrosive flux.
- If the PC board is pressed down into a flux-soaked sponge as shown on the right, the flux can easily penetrate a dust-cover type relay. Never use this method. Note that if the PC board is pressed down hard enough, flux may even penetrate a flux-resistant type relay.

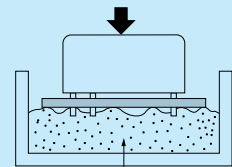

Bad example

3. Preheating

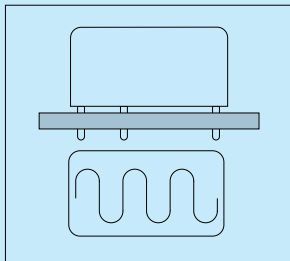

- Be sure to preheat before using automatic soldering. For dust-cover type relays and flux-resistant type relays, preheating acts to prevent the penetration of flux into the relay when soldering. Solderability also improves.
- Preheat according to the following conditions.

Temperature	120°C 248°F or less
Time	Within approx. 2 minutes

- Note that long exposure to high temperatures (e.g. due to a malfunctioning unit) may affect relay characteristics.

4. Soldering

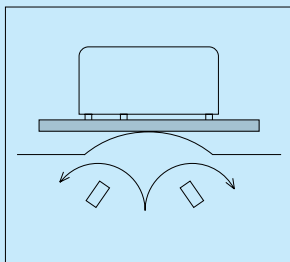

Please consult us regarding lead-free solder.

Automatic Soldering

- Flow solder is the optimum method for soldering.
- Adjust the level of solder so that it does not overflow onto the top of the PC board.
- Unless otherwise specified, solder under the following conditions depending on the type of relay.

Solder Temperature	Approx. 260°C 500°F
Soldering Time	Within approx. 6 seconds

Hand Soldering

- Keep the tip of the soldering iron clean.

Soldering Iron	30W to 60W
Iron Tip Temperature	Approx. 400°C 752°F
Soldering Time	Within approx. 3 seconds

Relay Soldering and Cleaning Guidelines

5. Cooling

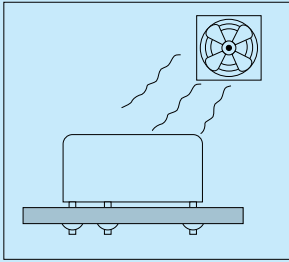

Automatic Soldering

- Immediate air cooling is recommended to prevent deterioration of the relay and surrounding parts due to soldering heat.
- Although the environmentally sealed type relay (plastic sealed type, etc.) can be cleaned, avoid immersing the relay into cold liquid (such as cleaning solvent) immediately after soldering. Doing so may deteriorate the sealing performance.

Hand Soldering

6. Cleaning

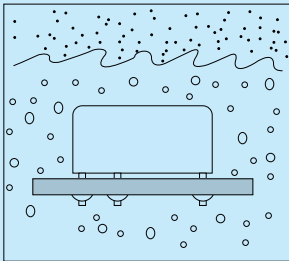

- Do not clean dust-cover type relays and flux-resistant type relays by immersion. Even if only the bottom surface of the PC board is cleaned (e.g. with a brush), careless cleaning may cause cleaning solvent to penetrate the relay.
- Plastic sealed type relays can be cleaned by immersion. Use a Freon- or alcohol-based cleaning solvent. Use of other cleaning solvents (e.g. Trichlene, chloroethene, thinner) may damage the relay case. However, some types of relays

use materials which are chemical resistant. Select the suitable relay or solvent by referring to the cleaning solvent compatibility chart below.

- Cleaning with the boiling method is recommended. Avoid ultrasonic cleaning on relays. Use of ultrasonic cleaning may cause breaks in the coil or slight sticking of the contacts due to the ultrasonic energy.

7. Coating

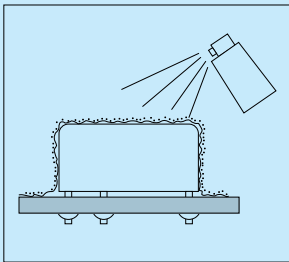

- If the PC board is to be coated to prevent the insulation of the PC board from deteriorating due to corrosive gases and high temperatures, note the following.
- Do not coat dust-cover type relays and flux-resistant type relays, since the coating material may penetrate the relay and cause contact failure. Or, mount the relay after coating.

- Depending on the type, some coating materials may have an adverse effect on relays. Furthermore, solvents (e.g. xylene, toluene, MEK, I.P.A.) may damage the case or chemically dissolve the epoxy and break the seal. Select coating materials carefully.

Type	Suitability for Relays	Features
Epoxy-base	Good	<ul style="list-style-type: none"> • Good electrical insulation. • Although slightly difficult to apply, does not affect relay contacts.
Urethane-base	Care	<ul style="list-style-type: none"> • Good electrical insulation, easy to apply. • Solvent may damage case. Check before use.
Silicon-base	No Good	<ul style="list-style-type: none"> • Silicon gas becomes the cause of contact failure. (also plastic sealed types) • Use a substitute that is not a silicon-base

- If the relay and all components (e.g. ICs) are to be coated, be sure to carefully check the flexibility of the coating material. The solder may peel off from thermal stress.
 - Transporting when mounted on PCBs
- Whether mounted or not, since relays are precision devices, do not apply vibration and shock that exceeds the stipulated value. Initial performance, as shipped from the factory, may be lost if undue vibration or shock is applied to the relay.

SMT Soldering Guidelines

CAUTIONS FOR SURFACE MOUNT RELAY INSTALLATION

To meet the market demand for downsizing to smaller, lighter, and thinner products, PC boards also need to proceed from Insertion mounting to

surface mounting technology. To meet this need, we offer a line of surface mount relays. The following describes some cautions required for surface mount relay

installation to prevent malfunction and incorrect operation.

• What is a Surface Mount Relay?

1. From IMT to SMT

Conventional insertion mount technology (IMT) with some 30 years of history is now being replaced with surface mount technology (SMT).

Solid-state components such as resistors, ICs, and diodes can withstand high heat stresses from reflow soldering because they use no mechanical parts. In contrast, the conventional electro-mechanical relays consisting of solenoid coils, springs, and armatures are very sensitive to thermal stress from reflow soldering.

We applied the experience gained from our advanced relay technologies to produce high-performance

electromagnetic relays compatible with surface mount technologies such as IRS and VPS.

• Insertion Mount Technology vs. Surface Mount Technology

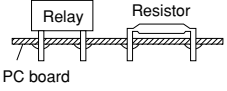
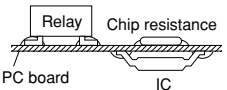
Insertion Mounting Technology: IMT	Components' leads are inserted into lead holes of PC board and are soldered to copper pads on the other side of the board using flow-soldering techniques.	
Surface Mount Technology (SMT)	Components are placed on copper pads pre-coated with paste solder and the board assembly is heated to solder the components on the pads (reflow soldering).	

2. Features and Effects

Features	Effects
<ul style="list-style-type: none"> Allows high density mounting Components can be installed on both sides of a board Ceramic PC boards can be used 	System downsizing
<ul style="list-style-type: none"> Compatible with automatic placement by robots Drilling for lead holes is not required Compact system designs are possible due to high density mounting 	Overall cost reduction
<ul style="list-style-type: none"> High heat resistance Anti-gas measures 	High reliability

The surface mount relay is manufactured with the following advanced technologies:

- Heat-resistance encapsulation technique
- Gas analysis
- Reliability assessment
- Precision molding technique for heat-resistant materials

• TQ-SMD Relay

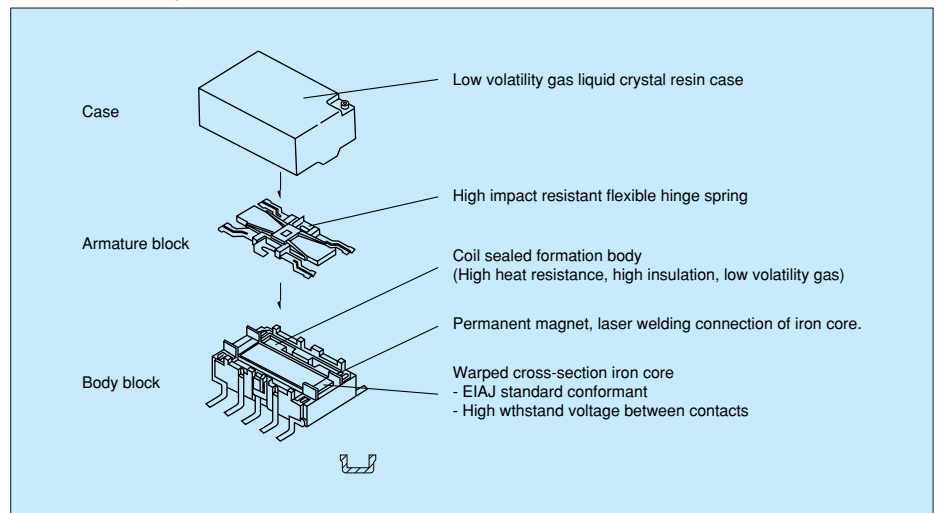

3. Examples of SMT Applications

The following describes some examples of typical SMT applications:

(1) Infrared Reflow Soldering (IRS)

IRS is the most popular reflow soldering technology now available for surface mounting. It uses a sheath heater or infrared lamp as its heat source. PC board assemblies are continuously soldered as they are transferred through a tunnel furnace comprised of a preheating, heating, and cooling-stages.

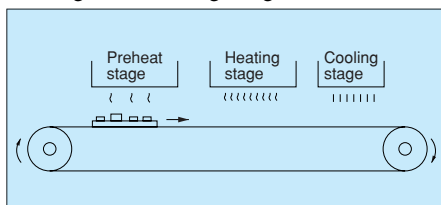

(2) Vapor Phase Soldering (VPS)

With VPS technology, PCB assemblies are carried through a special inactive solvent, such as Fluorinert FC-70, that has been heated to a vapor state. As the saturated vapor condenses on the PC board surface, the resulting evaporation heat provides the energy for reflow soldering.

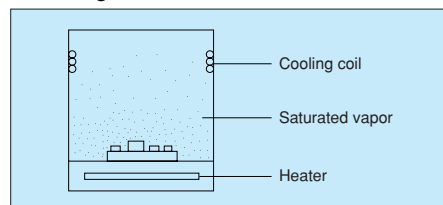

(3) Belt conveyer reflow furnace

As PCB assemblies are transferred on a thin, heat-resistant belt conveyer, they are soldered by the heat from hotplates placed beneath the conveyer belt.

(4) Double Wave Soldering (DWS)

Components are glued to the PC board surface. The board assembly is transferred through a molten solder fountain (with the component side facing down), and the components are soldered to the board.

(5) Other Technologies

Other reflow soldering technologies include those utilizing lasers, hot air, and pulse heaters.

SMT Soldering Guidelines

• Cautions for installation

1. Paste Soldering

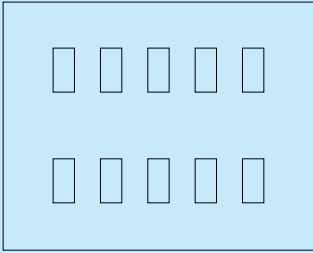

- Mounting pads on PC boards must be designed to absorb placement errors while taking account of solderability and insulation. Refer to the suggested mounting pad layout in the application data for the required relay product.
- Paste solder may be applied on the board with screen printing or dispenser techniques. For either method, the paste solder must be coated to appropriate thickness and shapes to achieve good solder wetting and adequate insulation.

Screen Printing

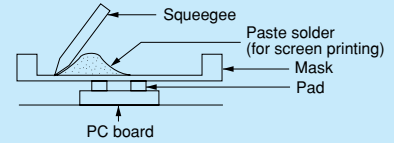

Solder Dispenser

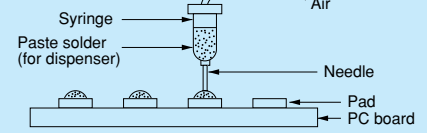

2. Relay Installation

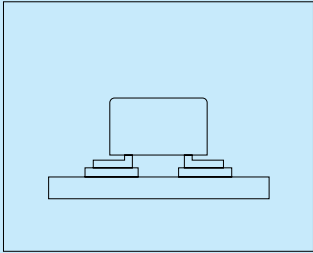

- For small, lightweight components such as chip components, a self-alignment effect can be expected if small placement errors exist. However, this effect is not as expected for electro-mechanical components such as relays, and they require precise positioning on their soldering pads.
- If SMT relays sustain excessive mechanical stress from the placement machine's pickup head, their performance cannot be guaranteed.

- Our SMT relays are supplied in stick packaging compatible with automatic placement processes. We also offer tape packaging at customer request.

Holding Pressure

Direction A: Less than 9.807 N (less than 1,000 gf)
 Direction B: Less than 9.807 N (less than 1,000 gf)
 Direction C: Less than 9.807 N (less than 1,000 gf)

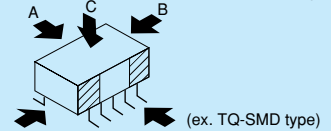

3. Reflow

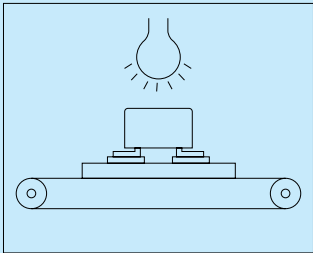

- Reflow soldering under inadequate soldering conditions may result in unreliable relay performance or even physical damage to the relay (even if the relay is of surface mount type with high heat resistance).
- Example of Recommended Soldering Condition for Surface Mount Relays.

(2) VPS technique

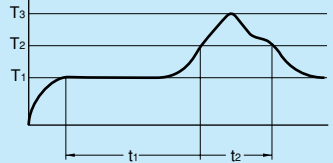

$T_1 = 90 \text{ to } 100^\circ\text{C}$ 194 to 212°F $t_1 = 90 \text{ to } 120 \text{ sec.}$
 $T_2 = 180 \text{ to } 200^\circ\text{C}$ 356 to 392°F $t_2 = \text{Less than } 60 \text{ sec.}$
 $T_3 = \text{Less than } 215^\circ\text{C}$ 419°F

(1) IRS technique

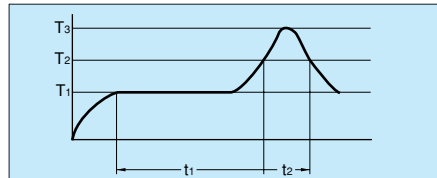

$T_1 = 155 \text{ to } 165^\circ\text{C}$ 311 to 329°F $t_1 = \text{Less than } 120 \text{ sec.}$
 $T_2 = 180 \text{ to } 200^\circ\text{C}$ 356 to 392°F $t_2 = \text{Less than } 30 \text{ sec.}$
 $T_3 = \text{Less than } 245^\circ\text{C}$ 473°F

<Reference>

Recommended temperature profile condition during reflow when using lead-free solder.

Please consult us correspondence products.

(3) Manual soldering

Soldering iron tip temperature: 280 to 300°C 536 to 572°F

Soldering iron wattage: 30 to 60 watts

Soldering time: Less than 5 sec.

(4) Others

When a soldering technique other than above is to be used (hot air, hotplate, laser, or pulse heater technique), carefully investigate the suitability of the technique.

Notes:

1. The soldering temperature profile indicates the pad temperature. In some cases, the ambient temperature may be greatly increased. Check for the specific mounting condition.
2. The preheating conditions for the VPS technique are identical to those for the IRS technique.

4. Cleaning

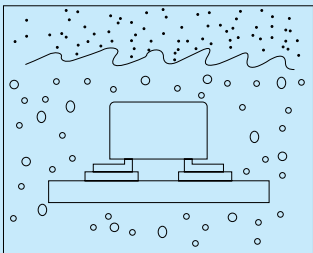

- The surface mount relays are solvent washable. Use alcohol or an equivalent solvent for cleaning.
- Boiled cleaning is approved for surface mount relays. Ultrasonic cleaning may cause coil damage or light contact sticking.

* Please consult us regarding lead-free solder.