

# LM.F-HD-SST | Levelling feet for ground mounting

Stainless steel, Hygienic Design



- 1
- 2
- 3
- 4
- 5
- 6
- 7
- 8
- 9
- 10
- 11
- 12
- 13
- 14
- 15
- 16
- 17
- 18

## MATERIAL

Fine turned AISI 304 stainless steel.

## UPPER RING OF THE PROTECTIVE SLEEVE (GBS)

NBR synthetic rubber hardness 70 +/-5 Shore A, blue colour, in compliance with FDA.

## LOWER RING OF THE PROTECTIVE SLEEVE (GBI)

Polyurethane elastomer TPU hardness 95 +/-5 Shore A, blue colour, in compliance with FDA.

## STEM RING (GST)

H-NBR synthetic rubber hardness 85 +/-5 Shore A, blue colour, in compliance with FDA.

## BASE RING (GBA)

Silicone hardness 85 +/-5 Shore A, blue colour, in compliance with FDA.

## FEATURES AND APPLICATIONS

LM.F-HD-SST levelling elements for ground mounting are intended for use in environments where high hygiene is required and are certified according to EHEDG guidelines.

The surface beneath the base is protected by rings that prevent dirt from entering, when the levelling element is mounted onto the supporting floor with screws through the holes provided in the element itself. The mounting and correct positioning of the holes is therefore essential for the sealing of the various rings.

For optimum mounting of the levelling element it is required the use of screws NT-HD-SST.

The adjustable protective sleeve, which covers the threaded part of the stem, is provided both at the top and bottom with a protective ring, as well as the base of the threaded stem. These rings prevent access to dirt inside the coupling between the threaded stud and the adjustable protective sleeve.

The finish quality of stainless steel parts prevents dirt adhering and facilitates cleaning.

The static load values in the table below are the result of laboratory tests in which the load has been applied perpendicularly to the base. Such values have to be considered as purely indicative and must be verified under the specific conditions of use.

Under common working conditions, side or angular loading increases the stress on the levelling element and reduces its carrying capacity.

It's the user's responsibility to determine, case by case, whether the product is suitable for the intended use.

See Hygienic Design technical data.

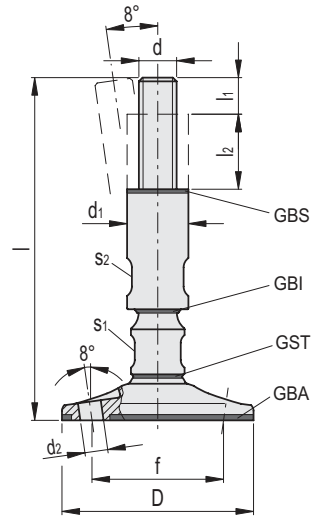

Conversion Table	
1 mm = 0.039 inch	
D	
mm	inch
80	3.12
100	3.90
120	4.68



Code	Description	D	d	d1	l	l1	l2	d2	f	s1	s2	Static load [N]	⚖
406201	LM.F-HD-80-SST-M12x175	80	M12	25	175	14	35	9.5	55.5	17	19	16000	1110
406211	LM.F-HD-80-SST-M12x225	80	M12	25	225	14	35	9.5	55.5	17	19	16000	1154
406213	LM.F-HD-80-SST-M16x175	80	M16	28	175	19	35	9.5	55.5	18	22	30000	1170
406215	LM.F-HD-80-SST-M16x225	80	M16	28	225	19	35	9.5	55.5	18	22	30000	1250
406221	LM.F-HD-80-SST-M20x185	80	M20	32	185	24	35	9.5	55.5	24	27	47000	1383
406223	LM.F-HD-80-SST-M20x235	80	M20	32	235	24	35	9.5	55.5	24	27	47000	1460
406225	LM.F-HD-80-SST-M24x185	80	M24	36	185	29	35	9.5	55.5	24	30	67000	1547
406227	LM.F-HD-80-SST-M24x235	80	M24	36	235	29	35	9.5	55.5	24	30	67000	1725
406231	LM.F-HD-100-SST-M16x175	100	M16	28	175	19	35	12	69	18	22	30000	1113
406236	LM.F-HD-100-SST-M16x225	100	M16	28	225	19	35	12	69	18	22	30000	1193
406241	LM.F-HD-100-SST-M20x185	100	M20	32	185	24	35	12	69	24	27	47000	1325
406246	LM.F-HD-100-SST-M20x235	100	M20	32	235	24	35	12	69	24	27	47000	1455
406251	LM.F-HD-100-SST-M24x185	100	M24	36	185	29	35	12	69	24	30	67000	1487
406256	LM.F-HD-100-SST-M24x235	100	M24	36	235	29	35	12	69	24	30	67000	1668
406261	LM.F-HD-120-SST-M16x175	120	M16	28	175	19	35	12	89	18	22	30000	1426
406266	LM.F-HD-120-SST-M16x225	120	M16	28	225	19	35	12	89	18	22	30000	1508
406271	LM.F-HD-120-SST-M20x185	120	M20	32	185	24	35	12	89	24	27	47000	1641
406276	LM.F-HD-120-SST-M20x235	120	M20	32	235	24	35	12	89	24	27	47000	1765
406281	LM.F-HD-120-SST-M24x185	120	M24	36	185	29	35	12	89	24	30	67000	1805
406286	LM.F-HD-120-SST-M24x235	120	M24	36	235	29	35	12	89	24	30	67000	1980

Levelling feet and supports