

ADM8698/ADM8699

FEATURES

Superior Upgrade for ADM698/ADM699, MAX698/MAX699
 Guaranteed $\overline{\text{RESET}}$ Assertion with $V_{CC} = 1\text{ V}$
 Low 70 μA Supply Current
 Precision 4.65 V Voltage Monitor
 Power OK/Reset Time Delay
 Watchdog Timer
 Minimum Component Count
 Performance Specified over Temperature

APPLICATIONS

Microprocessor Systems
 Computers
 Controllers
 Intelligent Instruments
 Automotive Systems
 Critical μP Power Monitoring

GENERAL DESCRIPTION

The ADM8698/ADM8699 supervisory circuits provide power supply monitoring and watchdog timing for microprocessor systems.

The ADM8698 monitors the 5 V V_{CC} power supply and generates a $\overline{\text{RESET}}$ pulse during power up, power down and during low voltage "Brown Out" conditions. The $\overline{\text{RESET}}$ output is guaranteed to be functional (logic low) with V_{CC} as low as 1 V.

The ADM8699 features an identical monitoring circuit as in the ADM8698, plus an additional watchdog timer input to monitor microprocessor activity. The $\overline{\text{RESET}}$ output is forced low if the watchdog input is not toggled within the 1 second watchdog timeout period.

Both parts are available in 8-pin plastic DIP/SOIC and 16-lead SOIC packages. The 16-lead SOIC contains additional outputs $\overline{\text{RESET}}$ (without inversion) and Watchdog Output $\overline{\text{WDO}}$ (ADM8699 only).

FUNCTIONAL BLOCK DIAGRAM

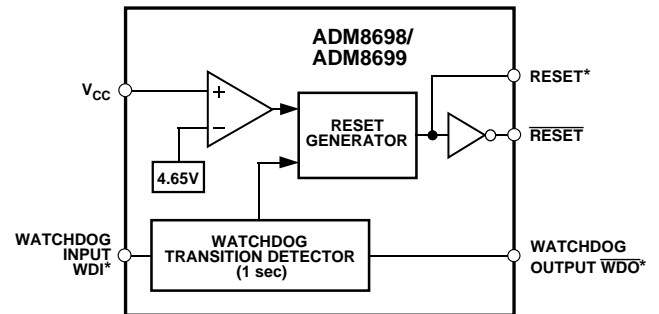

*WDI (ADM8699 ONLY)
 $\overline{\text{RESET}}$ (SOIC ONLY)
 $\overline{\text{WDO}}$ (ADM8699 SOIC ONLY)

TYPICAL APPLICATION CIRCUIT

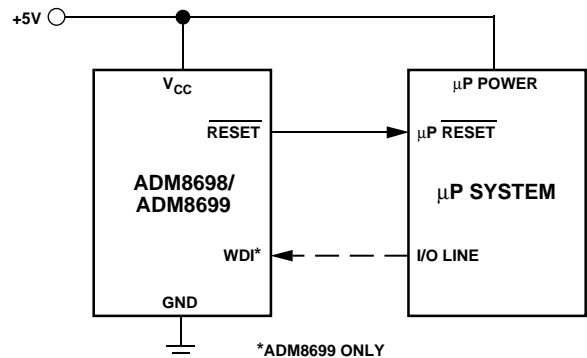

REV. 0

Information furnished by Analog Devices is believed to be accurate and reliable. However, no responsibility is assumed by Analog Devices for its use, nor for any infringements of patents or other rights of third parties which may result from its use. No license is granted by implication or otherwise under any patent or patent rights of Analog Devices.

ADM8698/ADM8699—SPECIFICATIONS ($V_{CC} = +5\text{ V} \pm 10\%$, $T_A = T_{MIN}$ to T_{MAX} unless otherwise noted)

Parameter	Min	Typ	Max	Units	Test Conditions/Comments
V_{CC} Operating Voltage Range	3.0		5.5	V	
Supply Current		70	100	μA	
Power-Down Reset Assertion	4.5	4.65	4.75	V	
Power-Up Reset Deassertion		40		mV	
Reset Threshold Hysteresis				ms	
Reset Active Time	140	200	280		
Watchdog Timeout Period (ADM8699)	1.0	1.6	2.25	s	
Minimum WDI Input Pulse Width	50			ns	$V_{IL} = 0.4$, $V_{IH} = 0.8$ (V_{CC})
$\overline{\text{RESET}}$ Output Voltage			0.4	V	$I_{SINK} = 3.2\text{ mA}$, $V_{CC} = 4.4\text{ V}$
$\overline{\text{RESET}}$ Output Voltage ($V_{CC} = 1\text{ V}$)		12	200	mV	$I_{SINK} = 100\ \mu\text{A}$, $V_{CC} = 1.0\text{ V}$
RESET and $\overline{\text{WDO}}$ Output Voltage	3.5			V	$I_{SOURCE} = 500\ \mu\text{A}$, $V_{CC} = 5\text{ V}$
RESET and $\overline{\text{WDO}}$ Output Voltage			0.4	V	$I_{SINK} = 3.2\text{ mA}$, $V_{CC} = 5\text{ V}$
RESET Output Short Circuit Current	3.5			V	$I_{SOURCE} = 1\ \mu\text{A}$, $V_{CC} = 4.4\text{ V}$
RESET Output Short Circuit Current		45		mA	Output Sink Current
WDI Input Threshold (ADM8699)					
Logic Low			0.8	V	
Logic High	3.5			V	
WDI Input Current		+1	+10	μA	$\text{WDI} = V_{CC}$
	-10	-1		μA	$\text{WDI} = 0\text{ V}$

Specifications subject to change without notice.

ABSOLUTE MAXIMUM RATINGS*

($T_A = +25^\circ\text{C}$ unless otherwise noted)

V_{CC}	-0.3 V to +6 V
All Other Inputs	-0.3 V to $V_{CC} + 0.3\text{ V}$
Power Dissipation 8-Pin DIP	500 mW
θ_{JA} , Thermal Impedance	+120°C/W
Power Dissipation 16-Pin SOIC	375 mW
θ_{JA} , Thermal Impedance	+110°C/W
Power Dissipation 8-Pin SOIC	500 mW
θ_{JA} , Thermal Impedance	+125°C/W
Operating Temperature Range	
Industrial (A Version)	-40°C to +85°C
Storage Temperature Range	-65°C to +150°C
Lead Temperature (Soldering, 10 secs)	+300°C
Vapor Phase (60 secs)	+215°C
Infrared (15 secs)	+220°C
ESD Rating	>4 kV

*Stresses above those listed under Absolute Maximum Ratings may cause permanent damage to the device. This is a stress rating only; functional operation of the device at these or any other conditions above those listed in the operational sections of this specification is not implied. Exposure to absolute maximum ratings for extended periods of time may affect device reliability.

ORDERING GUIDE

Model	Temperature Range	Package Options*
ADM8698AN	-40°C to +85°C	N-8
ADM8698ARW	-40°C to +85°C	R-16
ADM8698ARN	-40°C to +85°C	R-8
ADM8699AN	-40°C to +85°C	N-8
ADM8699ARW	-40°C to +85°C	R-16
ADM8699ARN	-40°C to +85°C	R-8

*N = Plastic DIP; R = Small Outline.

PIN FUNCTION DESCRIPTIONS

Mnemonic	Function
V _{CC}	+5 V Power Supply Input.
GND	0 V. Ground reference for all signals.
$\overline{\text{RESET}}$	Logic Output. $\overline{\text{RESET}}$ goes low whenever V _{CC} falls below the reset voltage threshold (4.65 V typ). $\overline{\text{RESET}}$ remains low for a minimum of 140 ms after V _{CC} returns to 5 V. $\overline{\text{RESET}}$ also goes low for a minimum of 140 ms if the watchdog timer is enabled but not serviced within its time-out period.
WDI	Watchdog Input. WDI is a three level input. If WDI remains either high or low for longer than the watchdog timeout period, $\overline{\text{RESET}}$ pulses low and $\overline{\text{WDO}}$ goes low. The timer resets with each transition on the WDI line. The watchdog timer may be disabled if WDI is left floating or is driven to midsupply.
RESET	(SOIC packages only) Logic Output. RESET is an active high output. It is the inverse of $\overline{\text{RESET}}$.
$\overline{\text{WDO}}$	(SOIC ADM8699 only) Logic Output. The Watchdog Output, $\overline{\text{WDO}}$, goes low if WDI remains either high or low for longer than the watchdog timeout period. $\overline{\text{WDO}}$ is set high by the next transition at WDI. If WDI is unconnected or at midsupply, the watchdog timer is disabled and $\overline{\text{WDO}}$ remains high.

TYPICAL PERFORMANCE CURVES

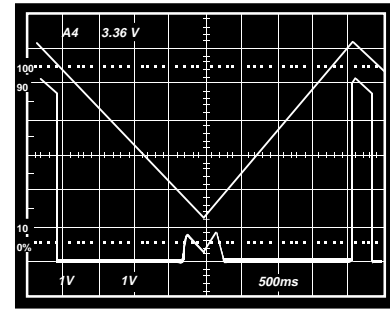

Figure 1. RESET Output Voltage vs. V_{CC}

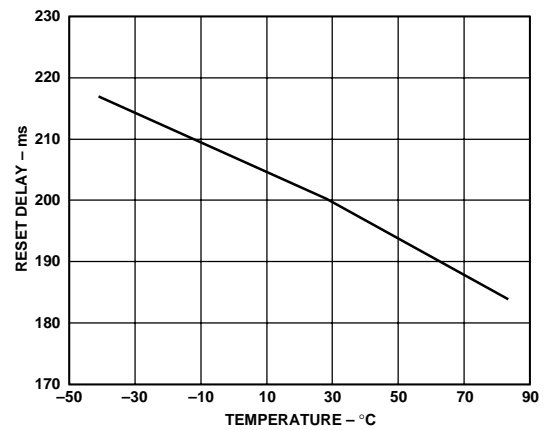

Figure 2. RESET Timeout Delay vs. Temperature

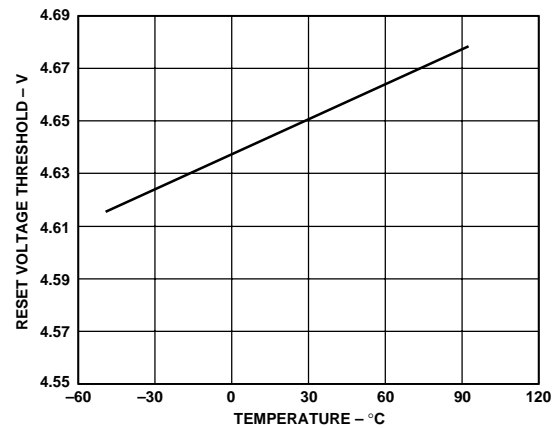
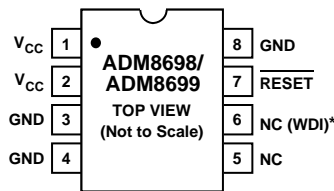

Figure 3. RESET Voltage Threshold vs. Temperature

PIN CONFIGURATIONS

8-Lead DIP & SOIC



*() ADM8699 ONLY
NC = NO CONNECT

16-Lead SOIC

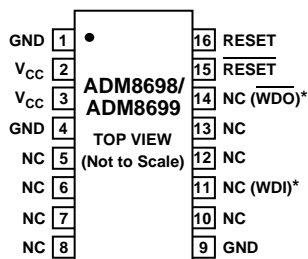

*() ADM8699 ONLY
NC = NO CONNECT

ADM8698/ADM8699

CIRCUIT INFORMATION

Power Fail RESET

A precision voltage detector monitors V_{CC} and generates a $\overline{\text{RESET}}$ output to hold the microprocessor's Reset line low when V_{CC} falls below the reset threshold 4.65 V (see Figure 4). The reset voltage threshold is set to accommodate a 5% variation on V_{CC} . The voltage detector has 40 mV hysteresis to ensure that glitches on V_{CC} do not activate the $\overline{\text{RESET}}$ output.

On power-up, an internal monostable holds $\overline{\text{RESET}}$ low for 140 ms after V_{CC} rises above the reset threshold. This allows the power supply to stabilize on power-up and also prevents repeated toggling of $\overline{\text{RESET}}$ even if the 5 V power drops out and recovers with each power line cycle. In order to prevent mistripping due to transient voltage spikes, it is recommended that a 0.1 μF capacitor be connected at the V_{CC} pin.

The $\overline{\text{RESET}}$ output is guaranteed to remain low with V_{CC} , as low as 1 V. This holds the microprocessor in a stable shutdown condition as the power supply comes up.

On the 16-lead SOIC package, an active high RESET output is also provided. This is the complement of $\overline{\text{RESET}}$ and is intended for microprocessors requiring an active high signal.

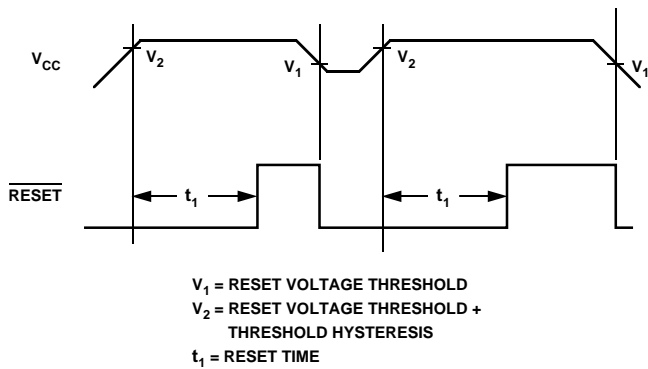

Figure 4. Watchdog Timeout Period vs. Temperature

Watchdog Timer (ADM8699 Only)

The watchdog timer input (WDI) monitors an I/O line from the μP system. The μP must toggle this input once every 1.6 seconds to verify correct software execution. Failure to toggle the line indicates that the μP system is not correctly executing its program and may be tied up in an endless loop. If this happens, a reset pulse is generated to initialize the processor.

The WDI input is a three level input and will recognize a low-to-high or high-to-low transition on its input. The watchdog timer is reset by each WDI transition and then begins its timeout period. If the WDI pin remains either high or low, reset pulses will be issued every 1.6 seconds typically. If the watchdog timer is not needed, the WDI input should be left floating.

The Watchdog Output ($\overline{\text{WDO}}$) (SOIC package Only) provides watchdog status information. It is driven low if WDI is not toggled within the watchdog timeout period. It goes high when V_{CC} falls below the reset threshold.

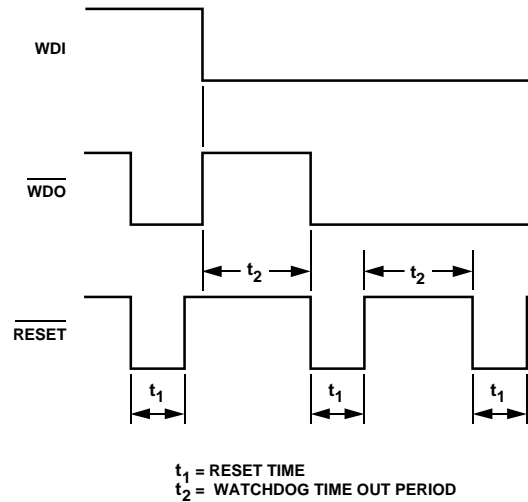
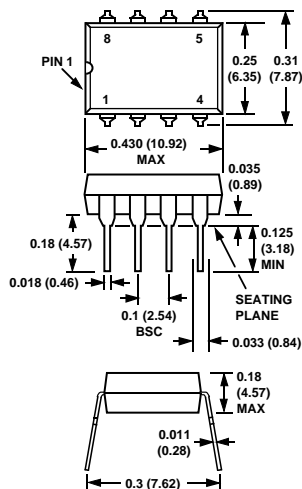

Figure 5. Watchdog Timeout Period and Reset Active Time

OUTLINE DIMENSIONS

Dimensions shown in inches and (mm).

8-Pin Plastic DIP (N-8)



8-Pin SOIC (R-8)

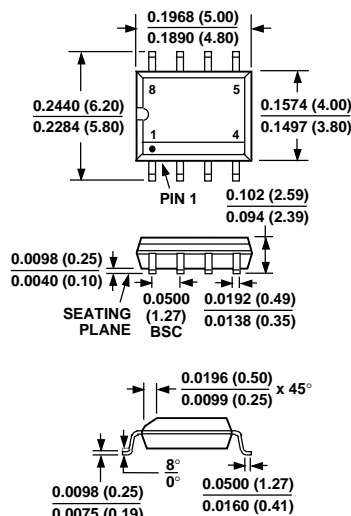

16-Lead SOIC (R-16)

