

LOC	DIST	REVISIONS			
DF	X5	REV	DESCRIPTION	DATE	BY
		A	RELEASED PER ECO-05-001646	06-05	AA DE

PART NO.	'A'	'B'
5830611-1	24.00 [609.6]	.25 [6.4]
5830611-9	30.00 [762.0]	.25 [6.4]
1-5830611-0	36.00 [914.4]	.25 [6.4]
1-5830611-1	8.00 [203.2]	.25 [6.4]
1-5830611-3	16.00 [406.4]	.38 [9.7]
1-5830611-6	5.00 [127.0]	.38 [9.7]
2-5830611-1	6.00 [152.4]	.38 [9.7]
2-5830611-3	48.00 [1219.2]	.38 [9.7]
2-5830611-5	18.00 [457.2]	.38 [9.7]
3-5830611-5	14.00 [355.6]	.38 [9.7]
4-5830611-2	15.50 [393.7]	.50 [12.7]
4-5830611-8	12.00 [304.8]	.38 [9.7]
5-5830611-1	120.00 [3048.0]	.38 [9.7]

1. TOLERANCE OF LEAD LENGTH:
 UP TO 24 INCHES [609.6] = ±.12 [±3.0]
 24 INCHES [609.6] & UP = ±1%
2. MARKED PER MIL-STD-130.
3. TO MATE WITH AMP LGH-1/2
 RECEPTACLE WITH .53 [13.4] BARREL DEPTH.
4. INSULATION CUT TO LENGTH 'B' BUT NOT REMOVED.
5. OPERATING VOLTAGE: 10 KVDC AT 0 TO 70,000 FEET, -55°C TO 125°C.

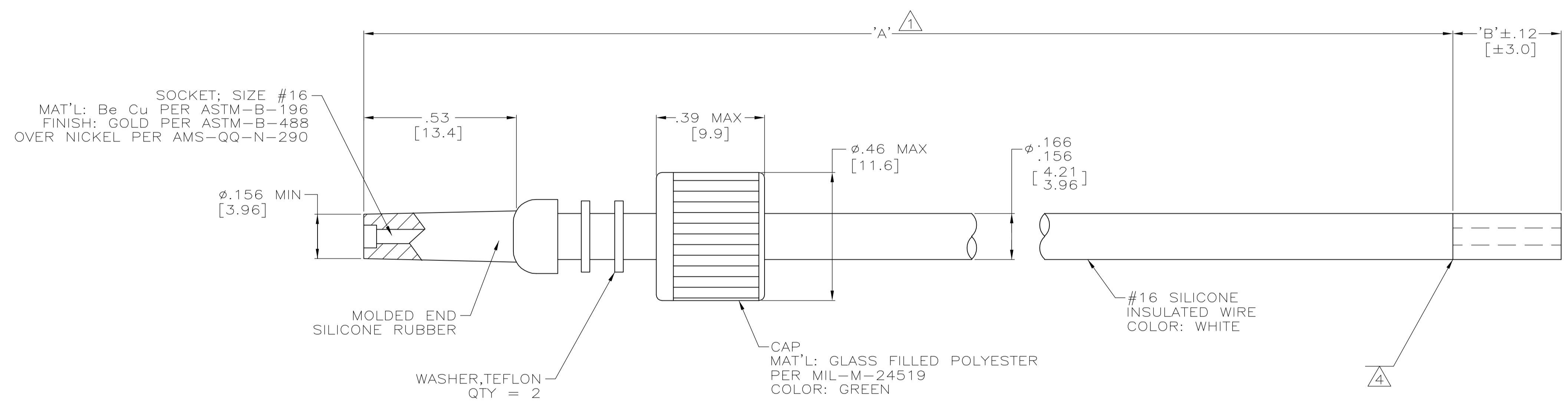

THIS DRAWING IS A CONTROLLED DOCUMENT.		DWG A.H.ANDERSON 09-JUN-05		Tyco Electronics Corporation Harrisburg, Pa 17105-3608
DIMENSIONS: INCHES		CHK D. FARY 09-JUN-05		NAME D. FARY
TOLERANCES UNLESS OTHERWISE SPECIFIED:		APPROD D. FARY 09-JUN-05	PRODUCT SPEC	RESTRICTED TO
0 PLC ± - 1 PLC ± - 2 PLC ± .02 [0.5] 3 PLC ± - 4 PLC ± - ANGLES ± -		APPLICATION SPEC	SIZE A1	CAGE CODE 00779
MATERIAL SEE CALLOUTS		FINISH SEE CALLOUTS	WEIGHT	DRAWING NO 5830611
		CUSTOMER DRAWING	SCALE 4:1	SHEET 1 OF 1