

| LOC | DIST | REVISIONS |     |                       |           |     |      |
|-----|------|-----------|-----|-----------------------|-----------|-----|------|
|     |      | P         | LTN | DESCRIPTION           | DATE      | OWN | APVD |
| AA  | 00   |           |     |                       |           |     |      |
|     |      | A2        |     | REV PER ECO-13-015117 | 16SEP2013 | OL  | SZ   |
|     |      | A3        |     | ADD NEW PART 6--2     | 18NOV2013 | OL  | SZ   |
|     |      | A4        |     | ECR-15-001425         | 19JAN2015 | SZ  | SZ   |

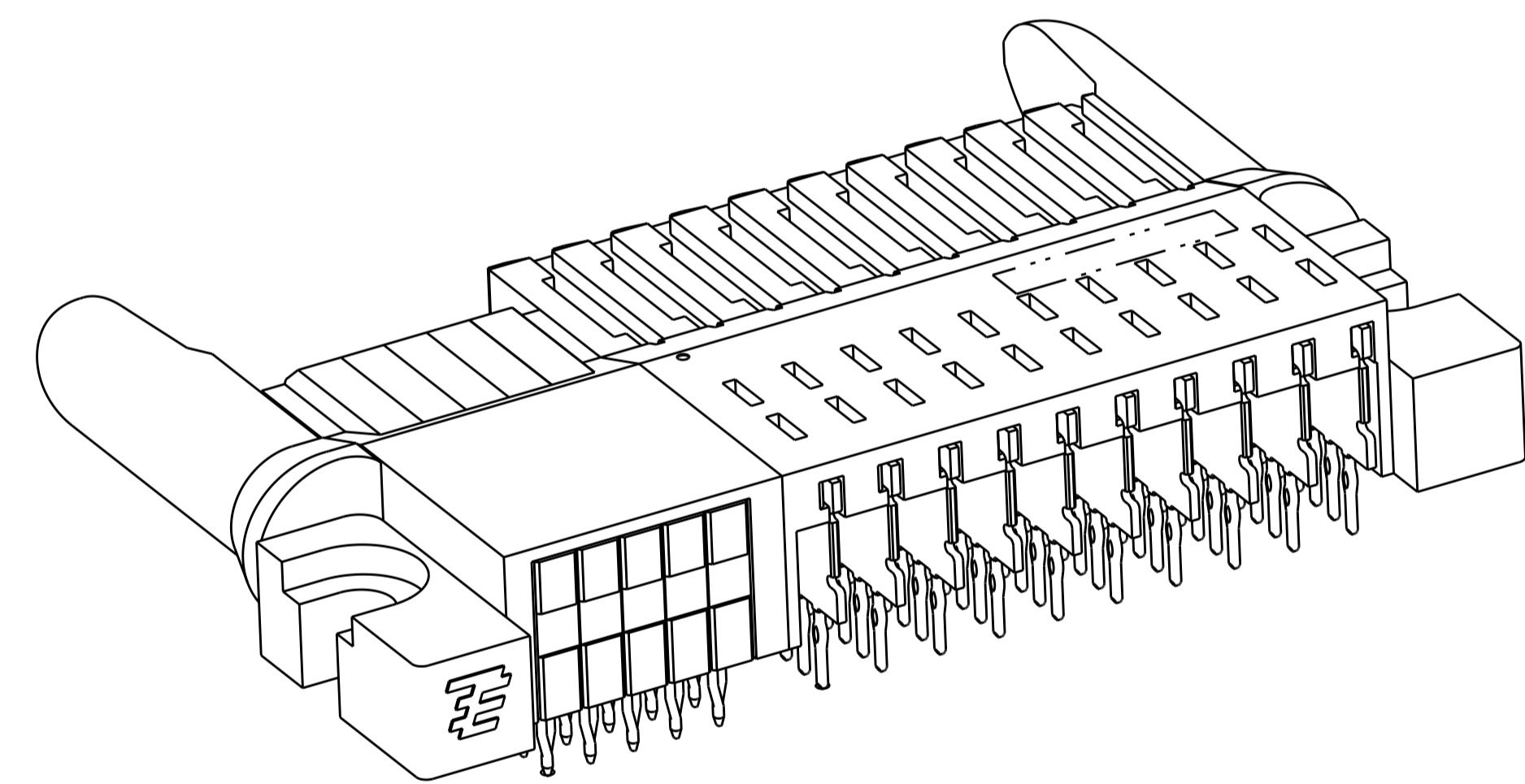
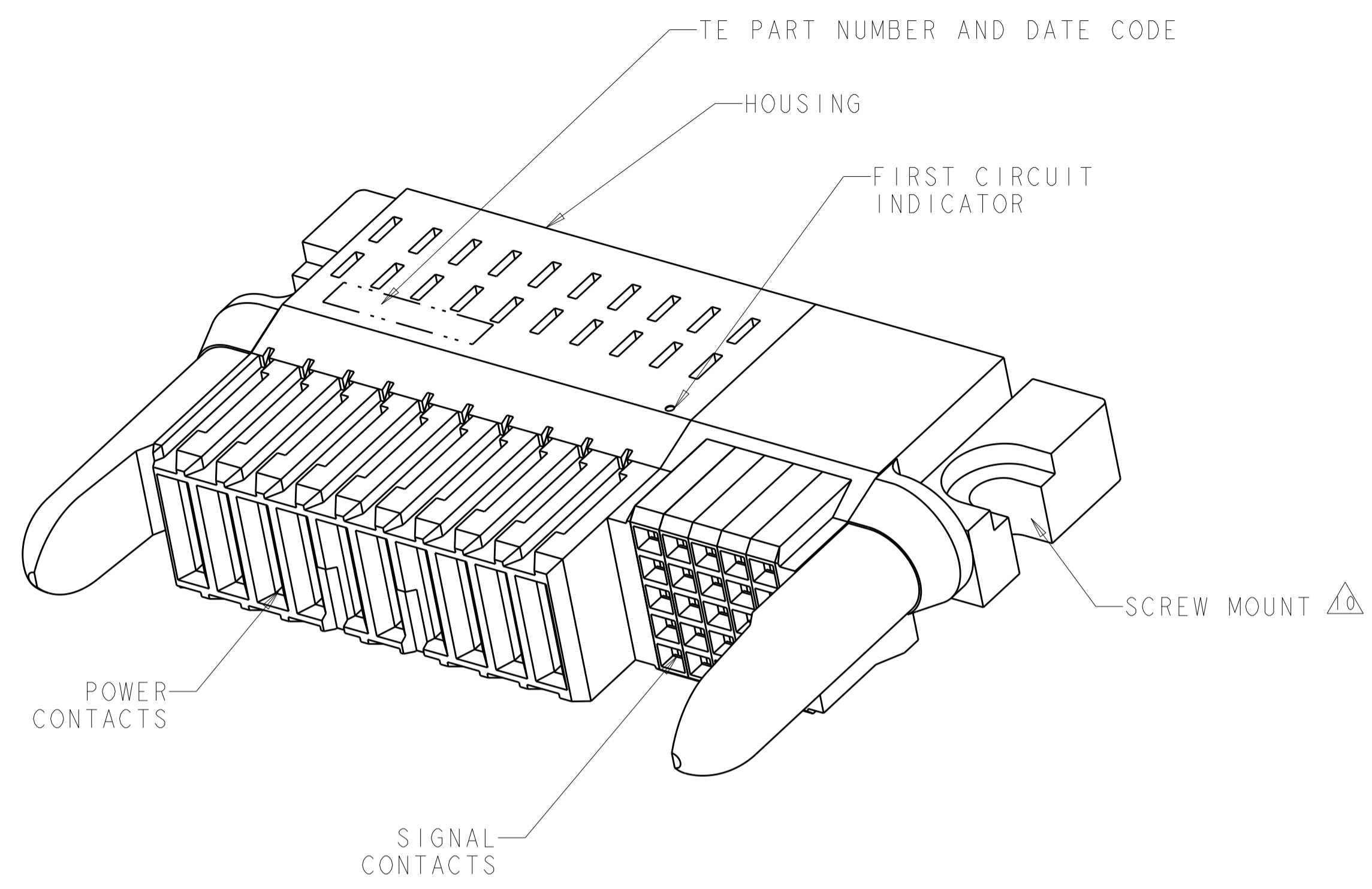

**2-1926739-5 SHOWN**

- HOUSING: GLASS FILLED LIQUID CRYSTAL POLYMER, COLOR: BLACK, UL 94 V-0 RATED  
 SIGNAL CONTACT: PHOSPHOR BRONZE  
 SIGNAL OVERMOLD: GLASS FILLED POLYESTER  
 POWER CONTACT: COPPER ALLOY
- SIGNAL CONTACT: 0.00127mm MIN NICKEL ALL OVER,  
 MATING AREA: 0.00008mm MIN GOLD OVER  
 0.00076mm MIN PALLADIUM-NICKEL  
 TAIL AREA: 0.0005mm MIN MATTE TIN  
  
 POWER CONTACT: 0.00127mm MIN NICKEL ALL OVER,  
 MATING AREA: 0.00008mm MIN GOLD OVER  
 0.00076mm MIN PALLADIUM-NICKEL,  
 TAIL AREA: 0.0005mm MIN MATTE TIN
- CONTACT MATING AREA LUBRICATED WITH BELLCORE APPROVED LUBRICANT,  
 TECHNICAL REFERENCE: GR-1217-CORE, ISSUE 1, NOVEMBER 1995
- THIS CONNECTOR EMPLOYS UL RECOGNIZED Z-PACK 2mm HM SIGNAL CONTACTS

- 5 DATUMS AND BASIC DIMENSIONS TO BE ESTABLISHED BY CUSTOMER
- 6 PC BOARD THICKNESS 1.4mm MIN, FOR WAVE SOLDER PC BOARD THICKNESS 2.62 MAX
- 7 SEE APPLICATION SPEC 114-13215 FOR PLATED THROUGH HOLE INFORMATION
- 8. SEE CUSTOMER DRAWING 1926730 OR 1926732 FOR MATING CONNECTOR
- 9 UNPLATED HOLES
- 10 #4-40 UNC PAN HEAD SCREW WITH HEX NUT, NOT SHOWN, SUPPLIED BY CUSTOMER

|          |          |             |             |       |       |                    |                |
|----------|----------|-------------|-------------|-------|-------|--------------------|----------------|
| 12       | 15       | 1           | 2           | 21.94 | 25.74 | 15S X 2P           | 8-1926739-0    |
| 144      | 40       | 23          | 7           | 92.44 | 96.24 | 40S X 24P          | 7-1926739-7    |
| 120      | 35       | 19          | 6           | 79.44 | 83.24 | 35S X 20P          | 6-1926739-2    |
| 108      | 35       | 17          | 6           | 73.94 | 77.74 | 35S X 18P          | 5-1926739-5    |
| 96       | 25       | 15          | 4           | 64.44 | 68.24 | 25S X 16P          | 4-1926739-6    |
| 72       | 15       | 11          | 2           | 49.44 | 53.24 | 15S X 12P          | 3-1926739-0    |
| 48       | 20       | 7           | 3           | 40.44 | 44.24 | 20S X 8P           | 1-1926739-1    |
| 72       | 25       | 11          | 4           | 51.44 | 57.24 | 25S X 12P          | 1926739-9      |
| 48       | 25       | 7           | 4           | 42.44 | 46.24 | 25S X 8P           | 1-1926739-8    |
| 36       | 20       | 5           | 3           | 36.74 | 40.54 | 20S X 6P           | 1-1926739-0    |
| 60       | 25       | 9           | 4           | 47.94 | 51.74 | 25S X 10P          | 2-1926739-5    |
| F<br>PLC | E<br>PLC | D<br>SPACES | C<br>SPACES | DIM B | DIM A | NO OF<br>POSITIONS | PART<br>NUMBER |

|  |  |   |  |  |  |  |  |  |  |
|--|--|---|--|--|--|--|--|--|--|
| DIMENSIONS:<br>mm<br>                      |  | TOLERANCES UNLESS OTHERWISE SPECIFIED:<br>0 PLC ±<br>1 PLC ±0.13<br>2 PLC ±<br>3 PLC ±<br>4 PLC ±<br>ANGLES ± |  | DIMENSIONS:<br>mm<br>0 PLC ±<br>1 PLC ±0.13<br>2 PLC ±<br>3 PLC ±<br>4 PLC ±<br>ANGLES ± |  | DIMENSIONS:<br>mm<br>0 PLC ±<br>1 PLC ±0.13<br>2 PLC ±<br>3 PLC ±<br>4 PLC ±<br>ANGLES ± |  | DIMENSIONS:<br>mm<br>0 PLC ±<br>1 PLC ±0.13<br>2 PLC ±<br>3 PLC ±<br>4 PLC ±<br>ANGLES ±   |  |
| MATERIAL: SEE NOTE 1<br>FINISH: SEE NOTE 2 |  | WEIGHT: -<br>Customer Drawing   |  | DWN: ORANDO LI 28OCT2011<br>CHK: SUNY ZHAO 28OCT2011<br>APVD: SUNY ZHAO 28OCT2011        |  | Tyco Electronics<br>Shanghai, PR 200233  |  | NAME: RECEPTACLE ASSEMBLY, RIGHT ANGLE, PASSIVE GUIDE, SIGNAL/POWER, WITH SCREW MOUNT, MINIPAK HDL<br>SIZE: A100779<br>CAGE CODE: 1926739<br>DRAWING NO: 1926739-5 |  |
| SCALE: 3:1                                 |  | SHEET 1 OF 3  |  | REV: A4  |  | RESTRICTED TO  |  | Customer Drawing   |  |

| LOC |     | DIST        |      | REVISIONS |      |  |  |
|-----|-----|-------------|------|-----------|------|--|--|
| P   | LTN | DESCRIPTION | DATE | DMN       | APVD |  |  |
| -   | -   | SEE SHEET 1 | -    | -         | -    |  |  |
|     |     |             |      |           |      |  |  |
|     |     |             |      |           |      |  |  |

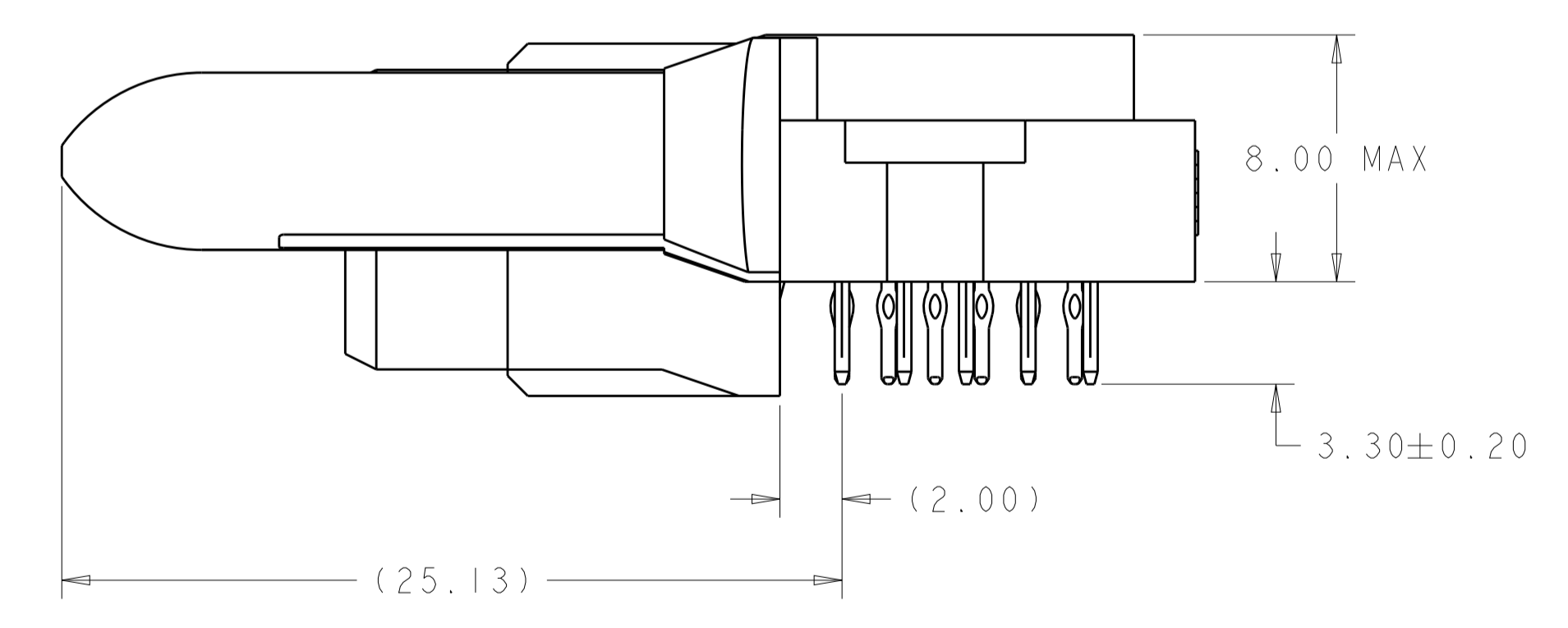
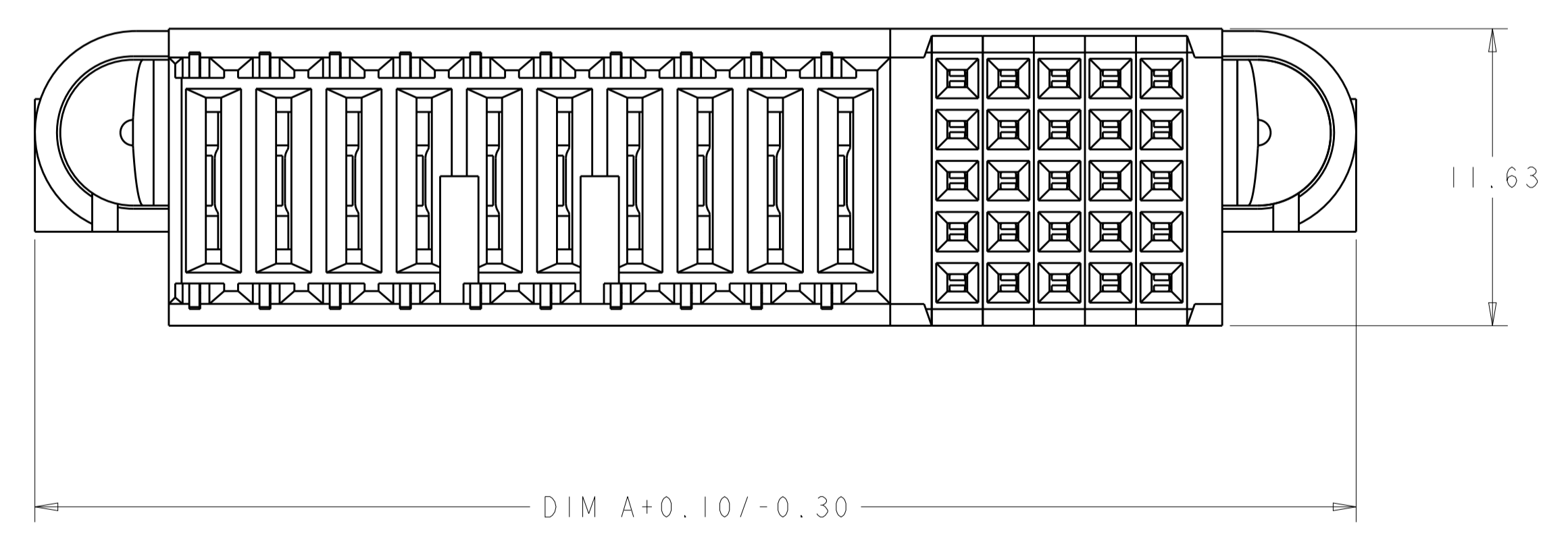
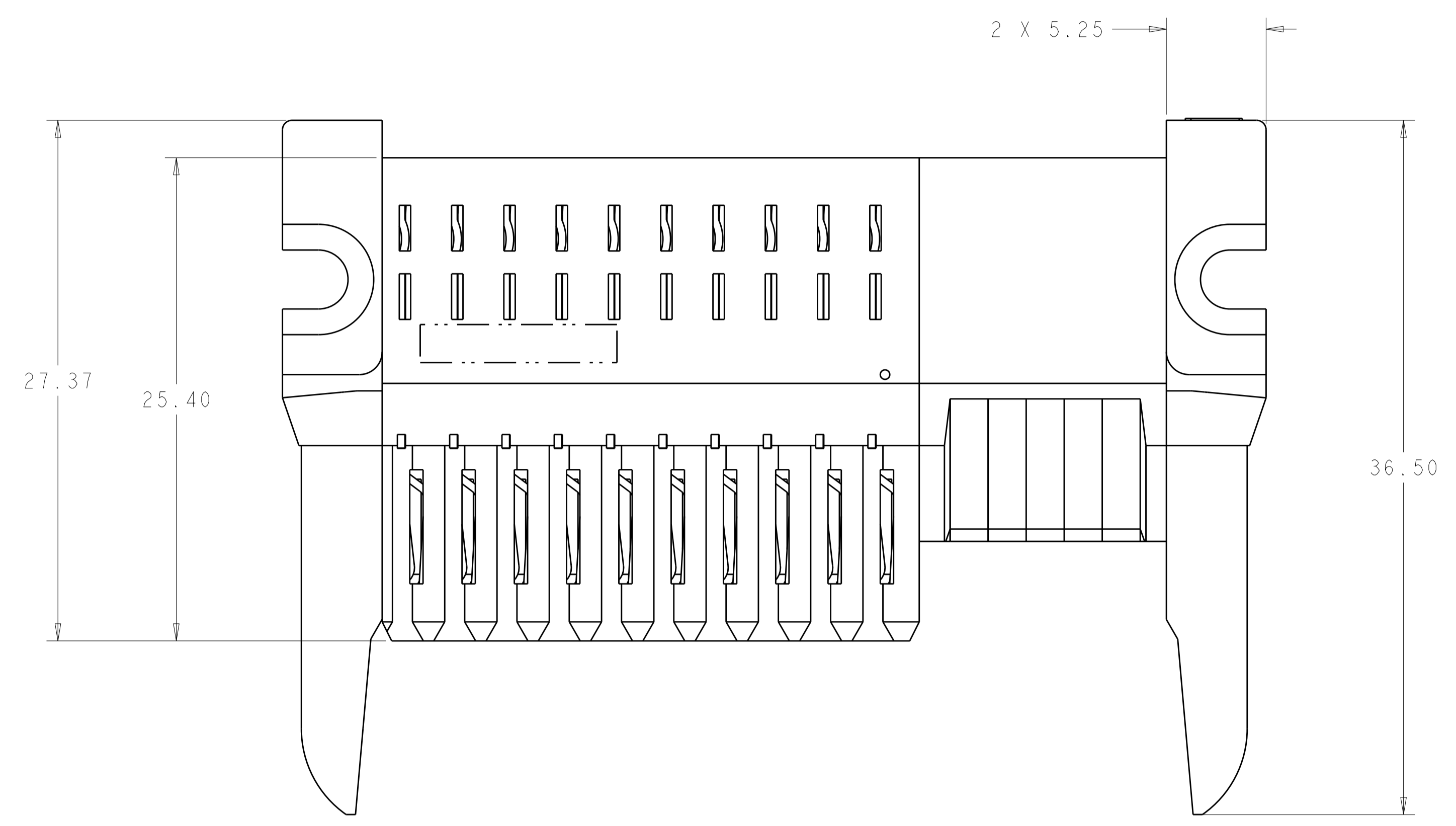

|  |  |  |   |
|--|--|--|---|
| <small>THIS DRAWING IS UNPUBLISHED. RELEASED FOR PUBLICATION BY TYCO ELECTRONICS CORPORATION. ALL RIGHTS RESERVED.</small> |  | DWN: ORANDO LI 28OCT2011<br>CHK: SUNY ZHAO 28OCT2011<br>APVD: SUNY ZHAO 28OCT2011  | Tyco Electronics<br>Shanghai, PR 200233                                 |
| DIMENSIONS:<br>mm<br>  | TOLERANCES UNLESS OTHERWISE SPECIFIED:<br>0 PLC ±<br>1 PLC ±0.13<br>2 PLC ±<br>3 PLC ±<br>4 PLC ±<br>ANGLES ±<br>FINISH SEE NOTE 2 | NAME: RECEPTACLE ASSEMBLY, RIGHT ANGLE, PASSIVE GUIDE, SIGNAL/POWER, WITH SCREW MOUNT, MINIPAK HDL<br>PRODUCT SPEC: 108-2325<br>APPLICATION SPEC: 114-13215<br>WEIGHT: -<br>Customer Drawing | SIZE: A<br>CAGE CODE: 1926739<br>SCALE: 3:1<br>SHEET: 2 OF 3<br>REV: A4 |

| LOC | DIST | REVISIONS   |      |     |      |
|-----|------|-------------|------|-----|------|
| P   | LTN  | DESCRIPTION | DATE | DWN | APVD |
| -   | -    | SEE SHEET 1 | -    | -   | -    |
|     |      |             |      |     |      |
|     |      |             |      |     |      |

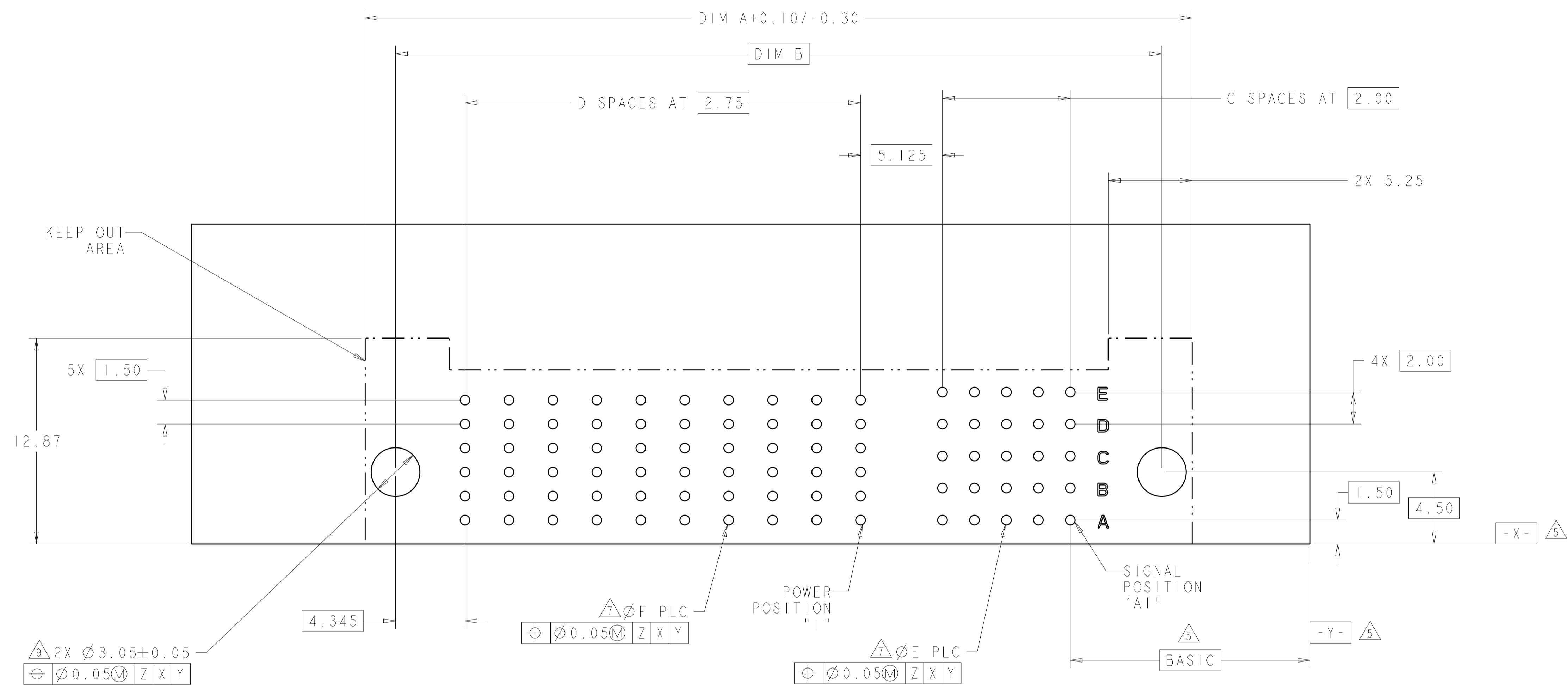

**2-1926739-5 SHOWN**  
**RECOMMENDED PRINTED CIRCUIT BOARD LAYOUT**  
 (AS VIEWED FROM COMPONENT SIDE)

|   |   |  |   |
|---|---|--|---|
| <small>THIS DRAWING IS UNPUBLISHED. IT IS THE PROPERTY OF TYCO ELECTRONICS CORPORATION. IT IS TO BE USED ONLY FOR THE PURPOSES AND IN THE QUANTITIES SPECIFIED IN THE ORDER. IT IS TO BE RETURNED TO TYCO ELECTRONICS CORPORATION UPON REQUEST.</small> |   | DWN: ORANDO LI 28OCT2011<br>CHK: SUNY ZHAO 28OCT2011<br>APVD: SUNY ZHAO 28OCT2011  | Tyco Electronics<br>Shanghai, PR 200233                                 |
| DIMENSIONS:<br>mm<br>   | TOLERANCES UNLESS OTHERWISE SPECIFIED:<br>0 PLC ±<br>1 PLC ±0.13<br>2 PLC ±<br>3 PLC ±<br>4 PLC ±<br>ANGLES ± | NAME: RECEPTACLE ASSEMBLY, RIGHT ANGLE, PASSIVE GUIDE, SIGNAL/POWER, WITH SCREW MOUNT, MINIPAK HDL<br>PRODUCT SPEC: 108-2325<br>APPLICATION SPEC: 114-13215<br>WEIGHT: - | SIZE: A1<br>CAGE CODE: 00779<br>DRAWING NO: 1926739<br>RESTRICTED TO: - |
| MATERIAL: SEE NOTE 1<br>FINISH: SEE NOTE 2  | SCALE: 3:1<br>SHEET: 3 OF 3<br>REV: A4  | Customer Drawing   | Tyco Electronics<br>Shanghai, PR 200233                                 |