

rev	ecn no	dr	date
A	---	JW	2012-08-22
-	-	-	-
-	-	-	-
-	-	-	-
-	-	-	-

spec ref	-	dr	Wei-Long Zhang	2011/08/03	projection	MM	size	A2	scale	4:1
tolerance std	ISO 406 ISO 1101	eng	Wei-Long Zhang	2012/08/22			ecn no	-	<b>Released</b>	rev <b>A</b>
surface	ISO 1302	chr	-	rel level			10118849			
		appr	Pei-Ming Zheng	2012/08/23	product family	HPCE	rel level	Product - Customer Drw	sheet 1 of 4	

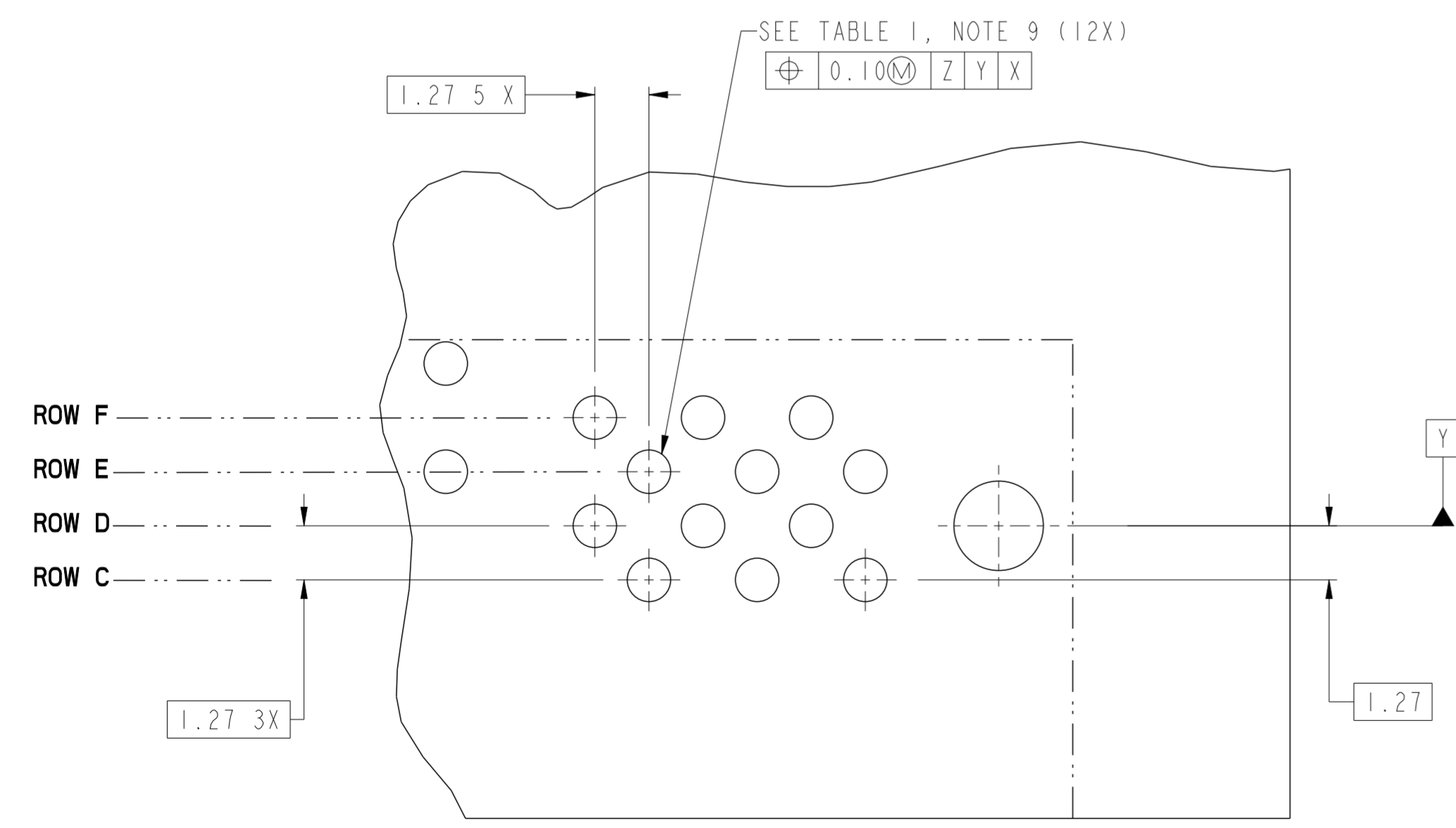

DETAIL K  
SCALE 8:1

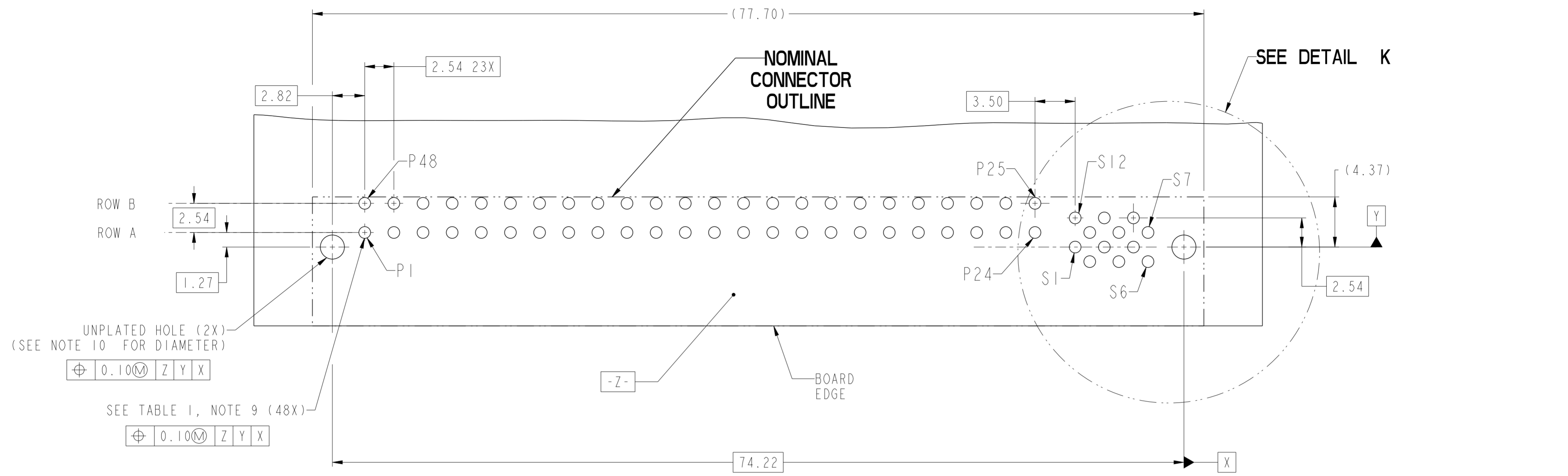
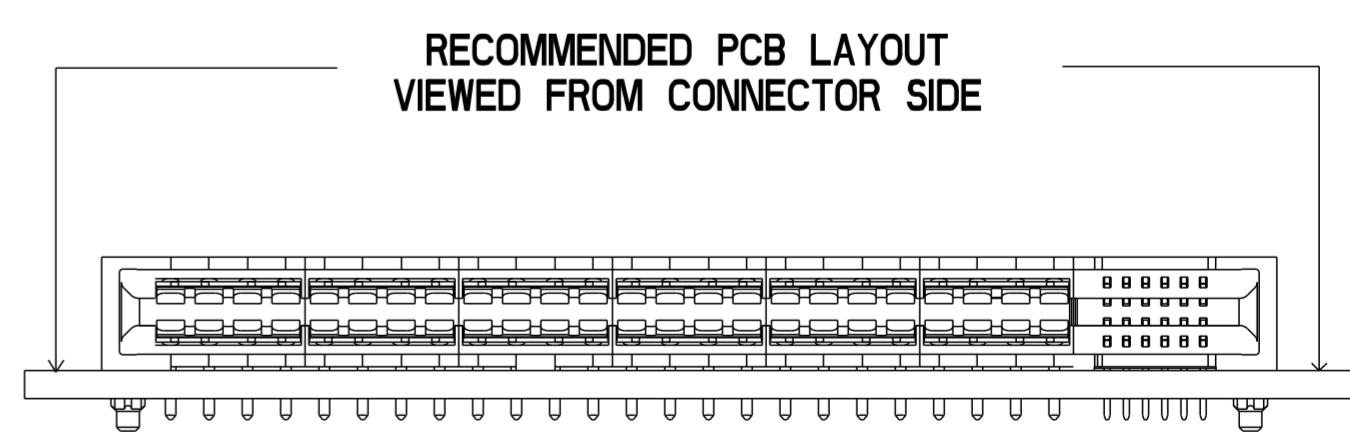

dr	Wei-Long Zhang	2011/08/03	projection	MM	size	A2	scale	4:1	
eng	Wei-Long Zhang	2012/08/22			ecn no.	-	rel level	Released	
chr	-	-			product family	HPCE			
appr	Pei-Ming Zheng	2012/08/23			title	RIGHT ANGLE 48P12S HIGH POWER CARD EDGE		rev	A
www.fci.com			cat. no.	-	Product - Customer Drw	sheet 2 of 4			

Copyright FCI. FCI

CONTACT TYPE	TOP LAYER DESCRIPTION	TABLE 1 (HPCE / SOLDER TAILS) PLATED THROUGH-HOLE REQUIREMENTS				
		DRILLED HOLE DIAMETER	COPPER THICKNESS	TIN-LEAD THICKNESS	TIN THICKNESS	FINISHED HOLE DIAMETER
POWER & SIGNAL	TIN-LEAD	1.10-1.16 (1.15 DRILL)	0.025 - 0.050	0.005 - 0.015	--	0.94 - 1.10
	IMMERSION TIN	1.10-1.16 (1.15 DRILL)	0.025 - 0.050	--	0.9 - 1.5um	0.94 - 1.10
	COPPER (SEE NOTE 8)	1.10-1.16 (1.15 DRILL)	0.025 - 0.050	--	--	0.94 - 1.10

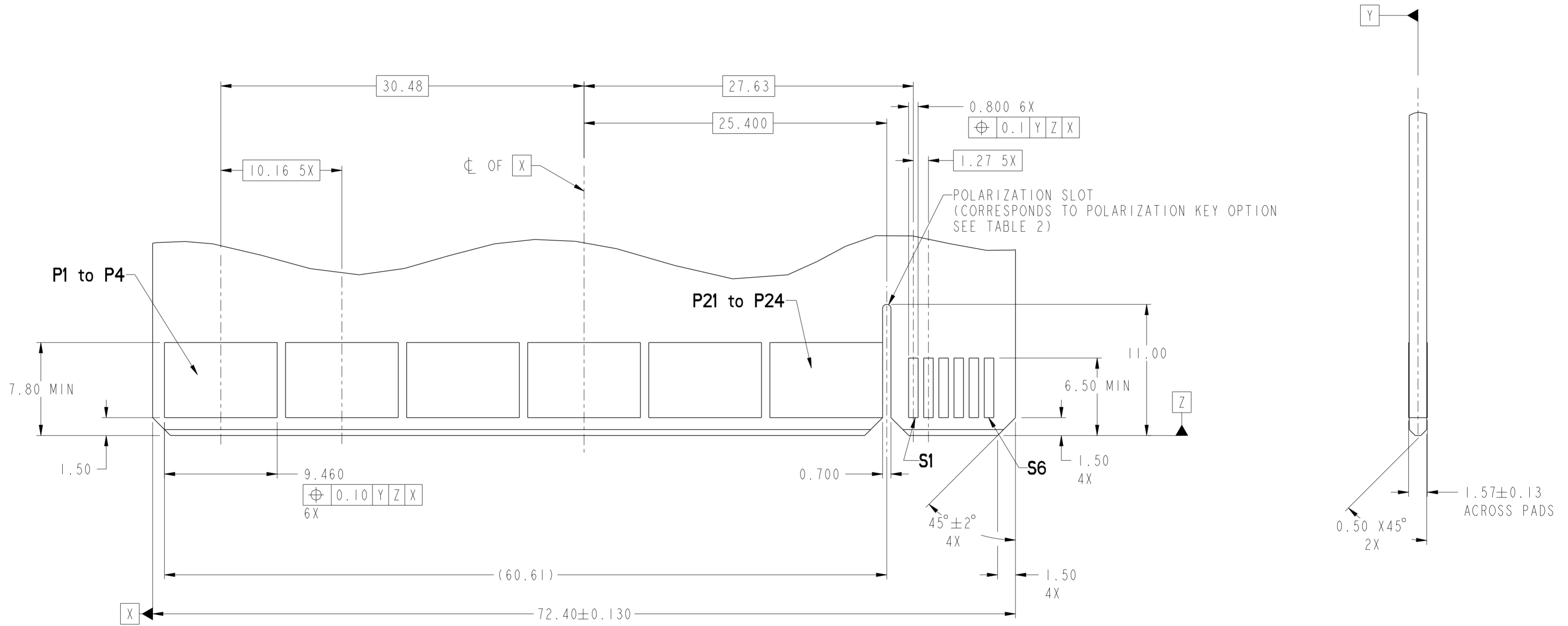

### RECOMMENDED MATING BOARD FOOTPRINT

dr	Wei-Long Zhang	2011/08/03	projection	MM	size	A2	scale	4:1
eng	Wei-Long Zhang	2012/08/22			ecn no	-	rel level	Released
chr	-	-						
appr	Pai-Ming Zheng	2012/08/23	product family	HPCE				
			title	RIGHT ANGLE 48P12S		dwg no	10118849	
www.fci.com			cat. no.	-		Product - Customer Drw	sheet 3 of 4	

HPCE PART NUMBER (TABLE 2)				
PRODUCT NUMBER	TAIL TYPE	HOLD-DOWN PEGS OPTION	POLARIZATION KEY OPTION	DIM "A" TYP TAIL LENGTH
10118849-001LF	SOLDER TAIL	NO	YES	3.25±0.50
10118849-002LF			NO	
10118849-003LF		YES	YES	
10118849-004LF			NO	

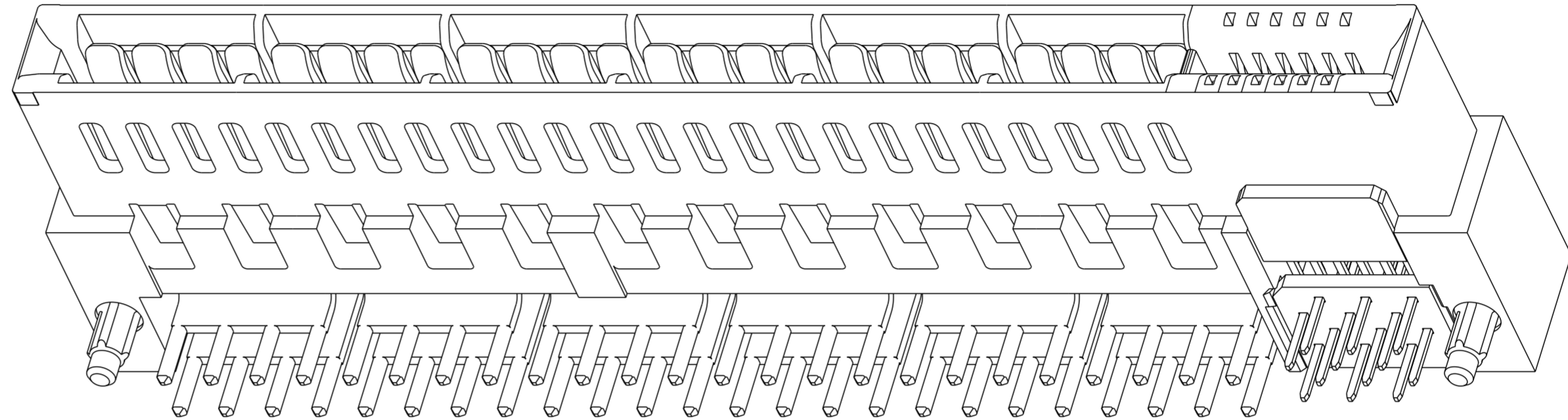

NOTES:

1. CONNECTOR MATERIALS:
  - HOUSING: HIGH TEMPERATURE THERMAL PLASTIC, BLACK  
UL 94V-0 COMPLIANT
  - CONTACTS: HIGH PERFORMANCE COPPER ALLOY.
2. CONTACT FINISH REF. GS-12-604 SECTION 5.2.
3. PRODUCT SPECIFICATION: GS-12-604.
4. APPLICATION SPECIFICATION: GS-20-128).
5. PRODUCT MARKING (FCI - PART NUMBER & DATE CODE) ON HOUSING IN AREA SHOWN.
6. PACKAGING MEETS FCI SPECIFICATION GS-14-937.
7. HOUSING COMPONENT WILL WITHSTAND EXPOSURE TO 260°C PEAK TEMPERATURE FOR 60 SECONDS IN A CONVECTION, INFRA-RED, OR VAPOR PHASE REFLOW OVEN.
8. COPPER PLATING THICKNESS IN CENTER OF VIA-HOLE CAN BE NO MORE THAN 0.003 LESS THAN OTHER AREAS.
9. ALL HOLE SIZES ARE FINISHED HOLE SIZES.
10. MOUNTING HOLES ARE UNPLATED  
Ø 2.18 +/- 0.03 FOR SOLDER TAILS

dr	Wei-Long Zhang	2011/08/03	projection	MM	size	A2	scale	4:1
eng	Wei-Long Zhang	2012/08/22			ecn no	-	rel level	Released
chr	-	-						
appr	Pei-Ming Zheng	2012/08/23	product family	HPCE				
			title	RIGHT ANGLE 48P12S		dwg no	10118849	
www.fci.com			cat. no.	-		rev	A	
			Product - Customer Drw			sheet 4 of 4		