



# 13 Output, 3.3V SDRAM Buffer for Desktop PCs with 3 DIMMs

## Features

- One input to 13 output buffer/driver
- Supports up to three SDRAM DIMMs
- One additional outputs for feedback
- Serial interface for output control
- Low skew outputs
- Up to 100-MHz operation
- Multiple  $V_{DD}$  and  $V_{SS}$  pins for noise reduction
- Low EMI outputs
- 28-pin SOIC (300-mil) package
- 3.3V operation

## Functional Description

The CY2313ANZ is a 3.3V buffer designed to distribute high-speed clocks in desktop PC applications. The part has 13 outputs, 12 of which can be used to drive up to three SDRAM DIMMs, and the remaining can be used for external feedback to a PLL. The device operates at 3.3V and outputs can run up to 100 MHz, thus making it compatible with Pentium® II processors. The CY2313ANZ can be used in conjunction with the CY2280, CY2281, CY2282 or similar clock synthesizer for a complete Pentium II motherboard solution.

The CY2313ANZ also includes a serial interface which can enable or disable each output clock. On power-up, all output clocks are enabled.

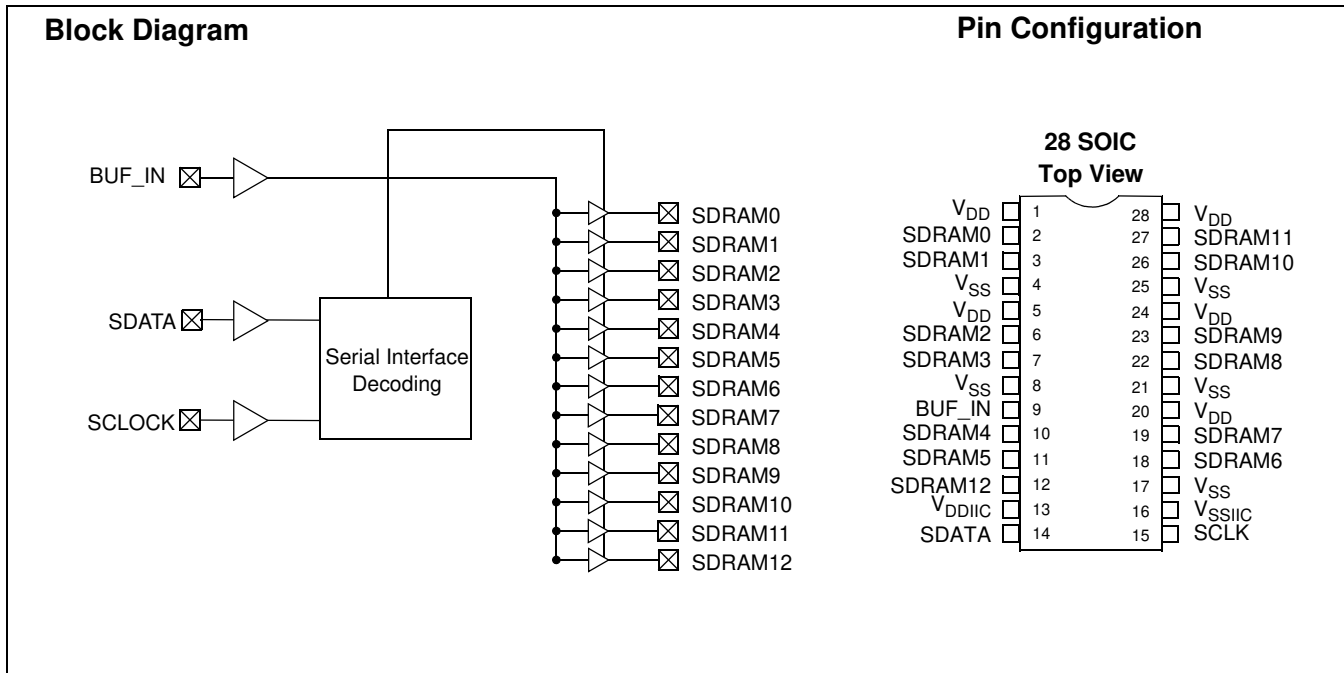

Pentium is a registered trademark of Intel Corporation.

**Pin Summary**

Name	Pins	Description
V <sub>DD</sub>	1, 5, 20, 24, 28	3.3V Digital voltage supply
V <sub>SS</sub>	4, 8, 17, 21, 25	Ground
V <sub>DDIIC</sub>	13	Serial interface voltage supply
V <sub>SSIIC</sub>	16	Ground for serial interface
BUF_IN	9	Input clock
SDATA	14	Serial data input, internal pull-up to V <sub>DD</sub>
SCLK	15	Serial clock input, internal pull-up to V <sub>DD</sub>
SDRAM [0-12]	2, 3, 6, 7, 10, 11, 12, 18, 19, 22, 23, 26, 27	SDRAM clock outputs

**Serial Configuration Map**

- The Serial bits will be read by the clock driver in the following order:
  - Byte 0 - Bits 7, 6, 5, 4, 3, 2, 1, 0
  - Byte 1 - Bits 7, 6, 5, 4, 3, 2, 1, 0
  - ...
  - Byte N - Bits 7, 6, 5, 4, 3, 2, 1, 0
- Reserved and unused bits should be programmed to "0"
- Serial interface address for the CY2313ANZ is:

A6	A5	A4	A3	A2	A1	A0	R/W
1	1	0	1	0	0	1	----

**Byte 0:SDRAM Active/Inactive Register  
(1 = Enable, 0 = Disable), Default = Enabled**

Bit	Pin #	Description
Bit 7	11	SDRAM5 (Active/Inactive)
Bit 6	10	SDRAM4 (Active/Inactive)
Bit 5	--	Reserved, drive to 0
Bit 4	--	Reserved, drive to 0
Bit 3	7	SDRAM3 (Active/Inactive)
Bit 2	6	SDRAM2 (Active/Inactive)
Bit 1	3	SDRAM1 (Active/Inactive)
Bit 0	2	SDRAM0 (Active/Inactive)

**Byte 1: SDRAM Active/Inactive Register  
(1 = Active, 0 = Inactive), Default = Active**

Bit	Pin #	Description
Bit 7	27	SDRAM11 (Active/Inactive)
Bit 6	26	SDRAM10 (Active/Inactive)
Bit 5	23	SDRAM9 (Active/Inactive)
Bit 4	22	SDRAM8 (Active/Inactive)
Bit 3	--	Reserved, drive to 0
Bit 2	--	Reserved, drive to 0
Bit 1	19	SDRAM7 (Active/Inactive)
Bit 0	18	SDRAM6 (Active/Inactive)

**Byte 2: SDRAM Active/Inactive Register  
(1 = Active, 0 = Inactive), Default = Active**

Bit	Pin #	Description
Bit 7	--	Reserved, drive to 0
Bit 6	12	SDRAM12 (Active/Inactive)
Bit 5	--	Reserved, drive to 0
Bit 4	--	Reserved, drive to 0
Bit 3	--	Reserved, drive to 0
Bit 2	--	Reserved, drive to 0
Bit 1	--	Reserved, drive to 0
Bit 0	--	Reserved, drive to 0

### Maximum Ratings

Supply Voltage to Ground Potential .....	-0.5V to +7.0V	Storage Temperature .....	-65°C to +150°C
DC Input Voltage (Except BUF_IN).....	-0.5V to $V_{DD} + 0.5V$	Junction Temperature.....	150°C
DC Input Voltage (BUF_IN).....	-0.5V to +7.0V	Static Discharge Voltage (per MIL-STD-883, Method 3015) .....	>2000V

### Operating Conditions<sup>[1]</sup>

Parameter	Description	Min.	Max.	Unit
$V_{DD}$	Supply Voltage	3.135	3.465	V
$T_A$	Operating Temperature (Ambient Temperature)	0	70	°C
$C_L$	Load Capacitance		30	pF
$C_{IN}$	Input Capacitance		7	pF
$t_{PU}$	Power-up time for all VDD's to reach minimum specified voltage (power ramps must be monotonic)	0.05	50	ms

### Electrical Characteristics Over the Operating Range

Parameter	Description	Test Conditions	Min.	Max.	Unit
$V_{IL}$	Input LOW Voltage <sup>[2]</sup>	Except serial interface pins		0.8	V
$V_{ILiic}$	Input LOW Voltage	For serial interface pins only		0.7	V
$V_{IH}$	Input HIGH Voltage <sup>[2]</sup>		2.0		V
$I_{IL}$	Input LOW Current (BUF_IN input)	$V_{IN} = 0V$	-10	10	$\mu A$
$I_{IL}$	Input LOW Current (Except BUF_IN Pin)	$V_{IN} = 0V$		100	$\mu A$
$I_{IH}$	Input HIGH Current	$V_{IN} = V_{DD}$	-10	10	$\mu A$
$V_{OL}$	Output LOW Voltage <sup>[3]</sup>	$I_{OL} = 25\text{ mA}$		0.4	V
$V_{OH}$	Output HIGH Voltage <sup>[3]</sup>	$I_{OH} = -36\text{ mA}$	2.4		V
$I_{DD}$	Supply Current <sup>[3]</sup>	Unloaded outputs, 100 MHz		200	mA
$I_{DD}$	Supply Current <sup>[3]</sup>	Loaded outputs, 100 MHz		290	mA
$I_{DD}$	Supply Current <sup>[3]</sup>	Unloaded outputs, 66.67 MHz		150	mA
$I_{DD}$	Supply Current <sup>[3]</sup>	Loaded outputs, 66.67 MHz		185	mA
$I_{DDS}$	Supply Current	BUF_IN= $V_{DD}$ or $V_{SS}$ All other inputs at $V_{DD}$		500	$\mu A$

**Notes:**

1. Electrical parameters are guaranteed under the operating conditions specified.
2. BUF\_IN input has a threshold voltage of  $V_{DD}/2$ .
3. Parameter is guaranteed by design and characterization. Not 100% tested in production.

**Switching Characteristics<sup>[4]</sup> Over the Operating Range**

Parameter	Name	Test Conditions	Min.	Typ.	Max.	Unit
	Maximum Operating Frequency				100	MHz
	Duty Cycle <sup>[3,5]</sup> = $t_2 \div t_1$	Measured at 1.5V	45.0	50.0	55.0	%
$t_3$	Rising Edge Rate <sup>[3]</sup>	Measured between 0.4V and 2.4V	0.9	1.5	4.0	V/ns
$t_4$	Falling Edge Rate <sup>[3]</sup>	Measured between 2.4V and 0.4V	0.9	1.5	4.0	V/ns
$t_5$	Output to Output Skew <sup>[3]</sup>	All outputs equally loaded	-250		+250	ps
$t_6$	SDRAM Buffer LH Prop. Delay <sup>[3]</sup>	Input edge greater than 1 V/ns	1.0	3.5	5.0	ns
$t_7$	SDRAM Buffer HL Prop. Delay <sup>[3]</sup>	Input edge greater than 1 V/ns	1.0	3.5	5.0	ns
$t_8$	SDRAM Buffer Enable Delay <sup>[3]</sup>	Input edge greater than 1 V/ns	1.0	5	12	ns
$t_9$	SDRAM Buffer Disable Delay <sup>[3]</sup>	Input edge greater than 1 V/ns	1.0	20	30	ns

**Notes:**

4. All parameters specified with loaded outputs.
5. Duty cycle of input clock is 50%. Rising and falling edge rate of the input clock is greater than 1 V/ns.

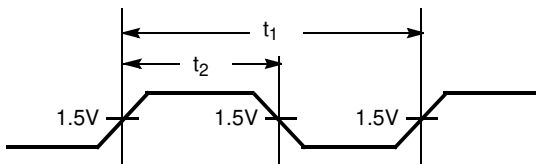
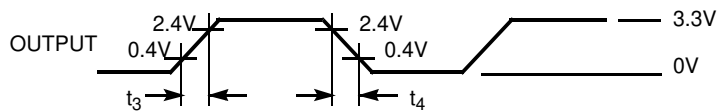
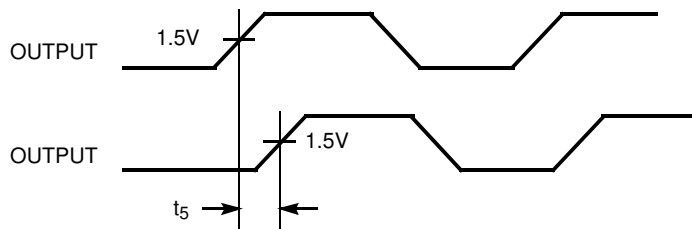
**Switching Waveforms**
**Duty Cycle Timing**

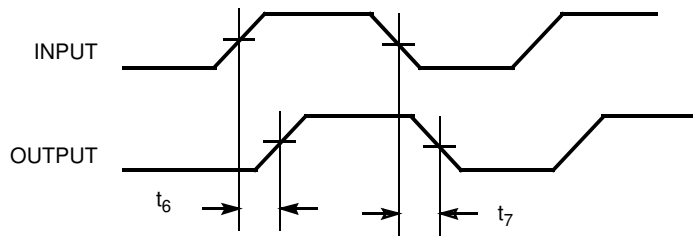
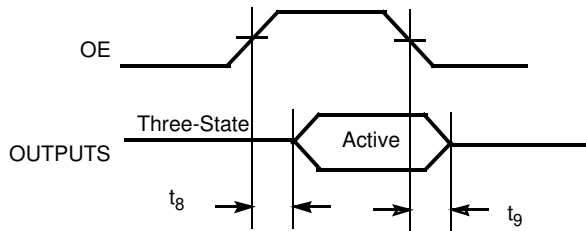
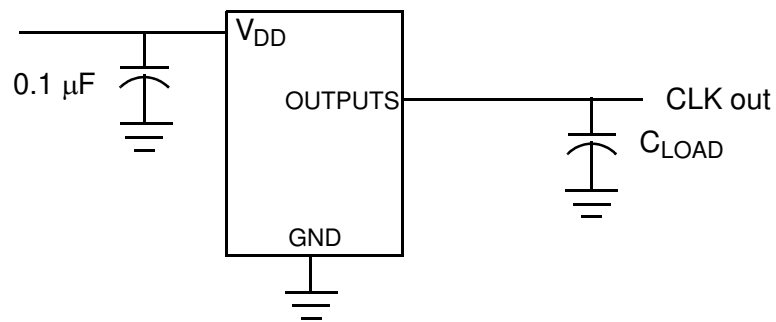
**All Outputs Rise/Fall Time**

**Output-Output Skew**

**Switching Waveforms (continued)**
**SDRAM Buffer LH and HL Propagation Delay**

**SDRAM Buffer Enable and Disable Times**

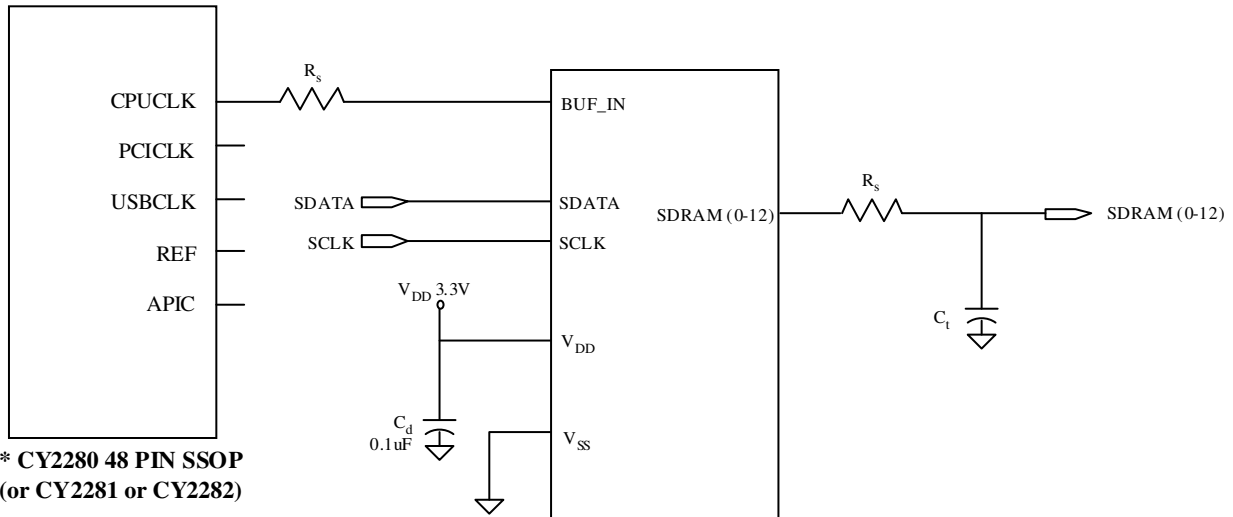
**Test Circuit**

## Application Information

Clock traces must be terminated with either series or parallel termination, as is normally done.

## Application Circuit



\* **CY2280 48 PIN SSOP**  
(or **CY2281** or **CY2282**)

**CY2313A: 28-PIN SOIC**

\* THIS FREQUENCY SYNTHESIZER IS USED TO GENERATE CPU, PCI, USB, REF, AND APIC CLOCKS.

$C_d$  = DECOUPLING CAPACITORS  
 $C_t$  = OPTIONAL EMI-REDUCING CAPACITORS  
 $R_s$  = SERIES TERMINATING RESISTORS

## Summary

- Surface mount, low-ESR, ceramic capacitors should be used for filtering. Typically, these capacitors have a value of 0.1  $\mu$ F. In some cases, smaller value capacitors may be required.
- The value of the series terminating resistor satisfies the following equation, where  $R_{trace}$  is the loaded characteristic impedance of the trace,  $R_{out}$  is the output impedance of the buffer (typically 25 $\Omega$ ), and  $R_{series}$  is the series terminating resistor.  
 $R_{series} > R_{trace} - R_{out}$
- Footprints must be laid out for optional EMI-reducing capacitors, which should be placed as close to the terminating resistor as is physically possible. Typical values of these capacitors range from 4.7 pF to 22 pF.
- A Ferrite Bead **may** be used to isolate the Board  $V_{DD}$  from the clock generator  $V_{DD}$  island. Ensure that the Ferrite Bead offers greater than 50 $\Omega$  impedance at the clock frequency, under loaded DC conditions. Please refer to the application note "Layout and Termination Techniques for Cypress Clock Generators" for more details.
- If a Ferrite Bead is used, a 10  $\mu$ F–22  $\mu$ F tantalum bypass capacitor should be placed close to the Ferrite Bead. This capacitor prevents power supply droop during current surges.

## Ordering Information

Ordering Code	Package Name	Package Type	Operating Range
CY2313ANZSC-1	S21	28-Pin SOIC	Commercial
Pb-free			
CY2313ANZSXC-1	S21	28-Pin SOIC	Commercial
CY2313ANZSXC-1T	S21	28-Pin SOIC Tape and Reel	Commercial

Package Diagram

28-Lead (300-Mil) Molded SOIC S21

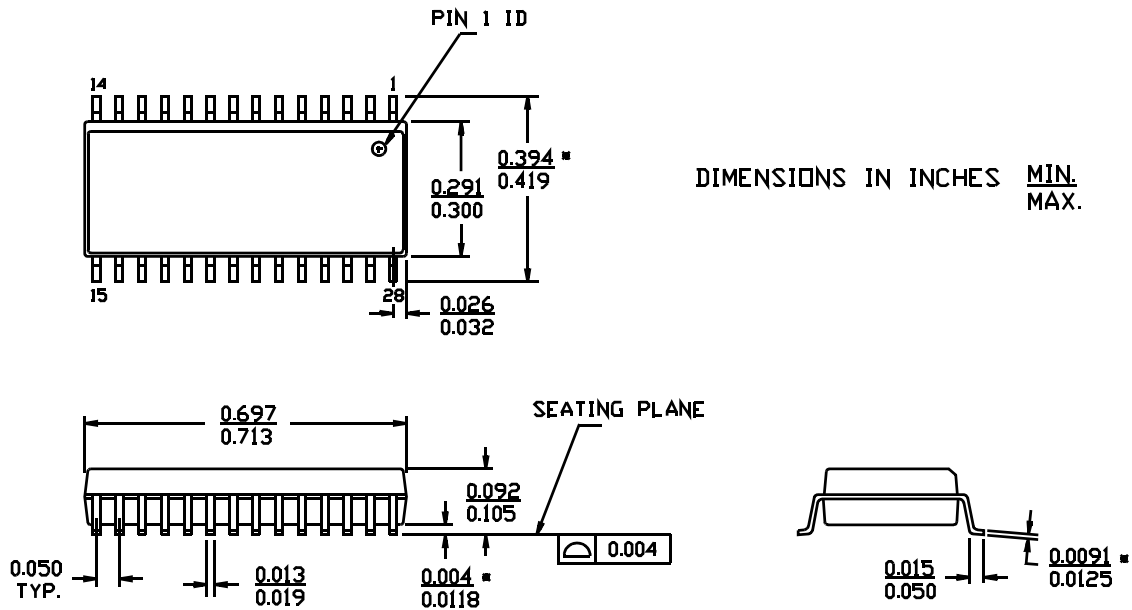

**Document History Page**

<b>Document Title: CY2313ANZ 13 Output, 3.3V SDRAM Buffer for Desktop PCs with 3 DIMMs</b>				
<b>Document Number: 38-07144</b>				
<b>REV.</b>	<b>ECN NO.</b>	<b>Issue Date</b>	<b>Orig. of Change</b>	<b>Description of Change</b>
**	110253	11/18/01	DSG	Change from Spec number: 38-00692 to 38-07144
*A	121831	12/14/02	RBI	Power up requirements added to Operating Conditions Information
*B	1244583	See ECN	DPF	Added Pb-free part numbers in the Ordering Information