

LOC		DIST		REVISIONS			
CM	00	REV	DATE	BY	CHK	APPV	
		K	13OCT11	REVISD PER ECO-11-014383	KH	SM	
		L	16SEP13	ECR-13-008537	M.T	D.Z	

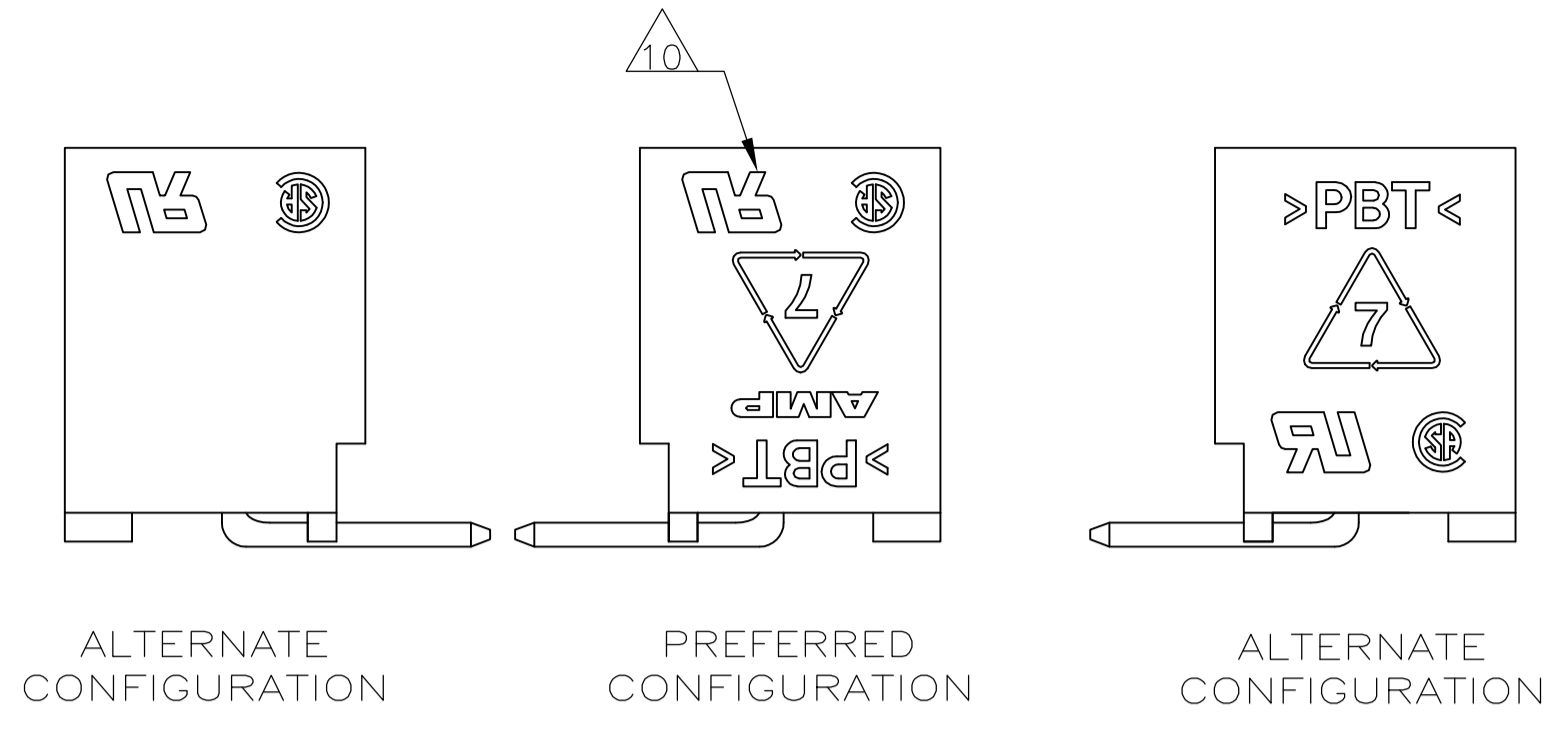

POSSIBLE MARKING CONFIGURATIONS SCALE 5:1

- 1 MATERIAL: HEADER- POLYESTER UL94V-0 (BLACK)
POST- COPPER ALLOY.
- 2 SOLDER SIDE OF P.C. BOARD SHOWN.
- 3 PARTS COMPLY WITH AMP SOLDERABILITY SPEC 109-11-2.
- 4 ONE HOLE MAY BE UNDERSIZED (.032-.035 DIA) FOR ASSEMBLY RETENTION DURING WAVE SOLDERING.
- 5 LATCH DETENT FEATURE OCCURS 2 PLACES ON EACH END (MAXIMUM OF FOUR PER PART). FOR 2 THRU 5 CIRCUIT HEADERS, LATCH FEATURE OCCURS BETWEEN EACH CIRCUIT.
- 6 COORDINATE DIMENSION APPLIES FROM CENTER OF ACTUAL FEATURE.
- 7 PLATING: GOLD PLATE AREA, .000030 GOLD OR .000003 MIN GOLD FLASH OVER .000027 PALLADIUM NICKEL, PER TE CONNECTIVITY'S DISCRETION, ALL SIDES, OVER NICKEL UNDERPLATE, .000050 MIN, ALL SIDES AND ENTIRE LENGTH OF POST.
- 8 TIN PLATE ALL FOUR SIDES, .140 REF. ON -2 THRU 1--4, 100% TIN FOR 2--2 THRU 3--4.
- 9 POST MUST WITHSTAND 3.0 LBS MIN FORCE WITHOUT DISLODGING, EITHER DIRECTION.
- 10 UL AND CSA LOGO WILL APPEAR IN THIS AREA. AMP LOGO MAY APPEAR IN THIS AREA OR ON BOTTOM OF PART.
- 11 SLOTS MAY OR MAY NOT APPEAR ON THESE PARTS.
- 12 OBSOLETE PARTS: OBSOLETE CIS STREAMLINING PER D.RENAUD/D.SINISI

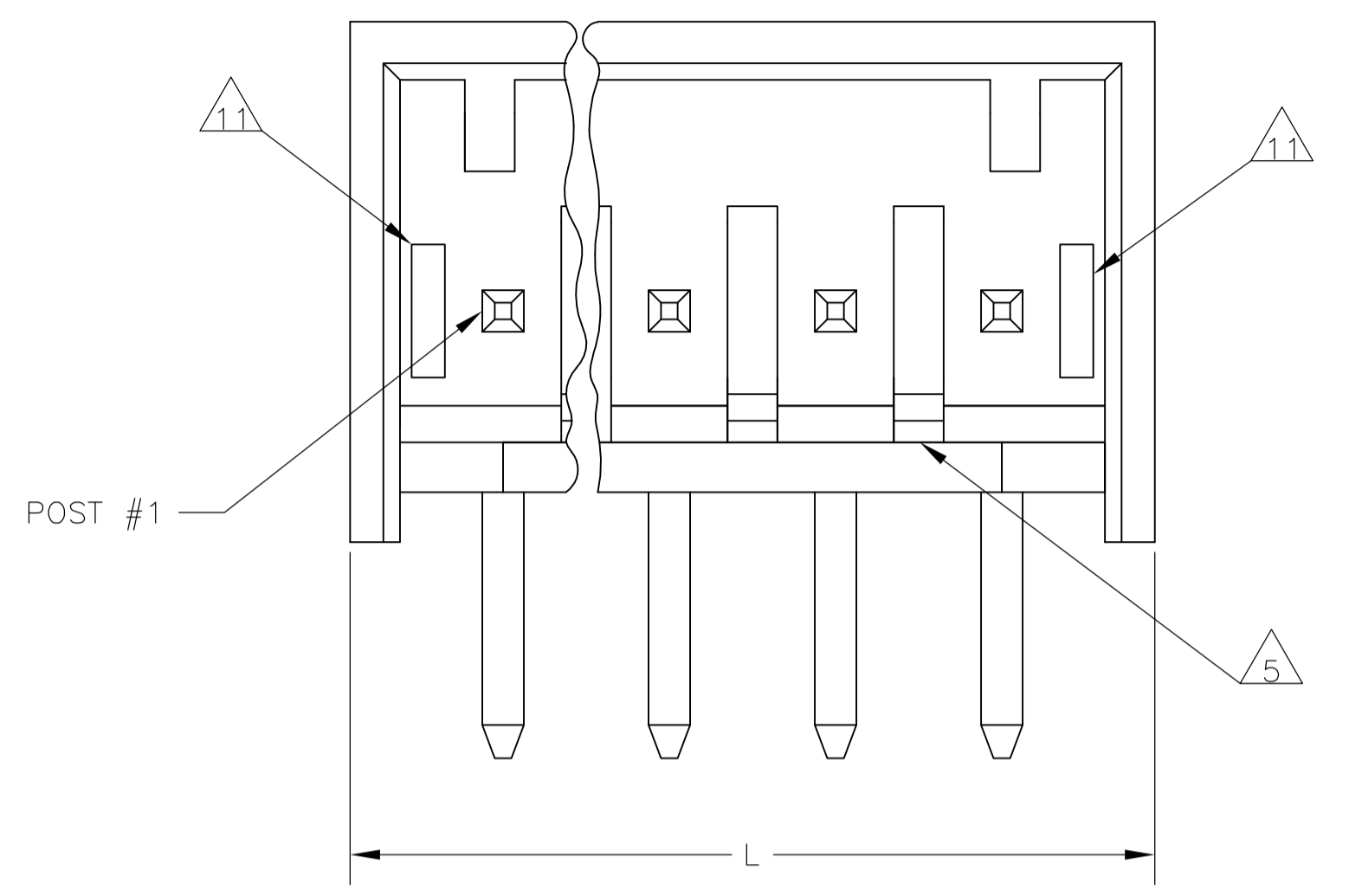
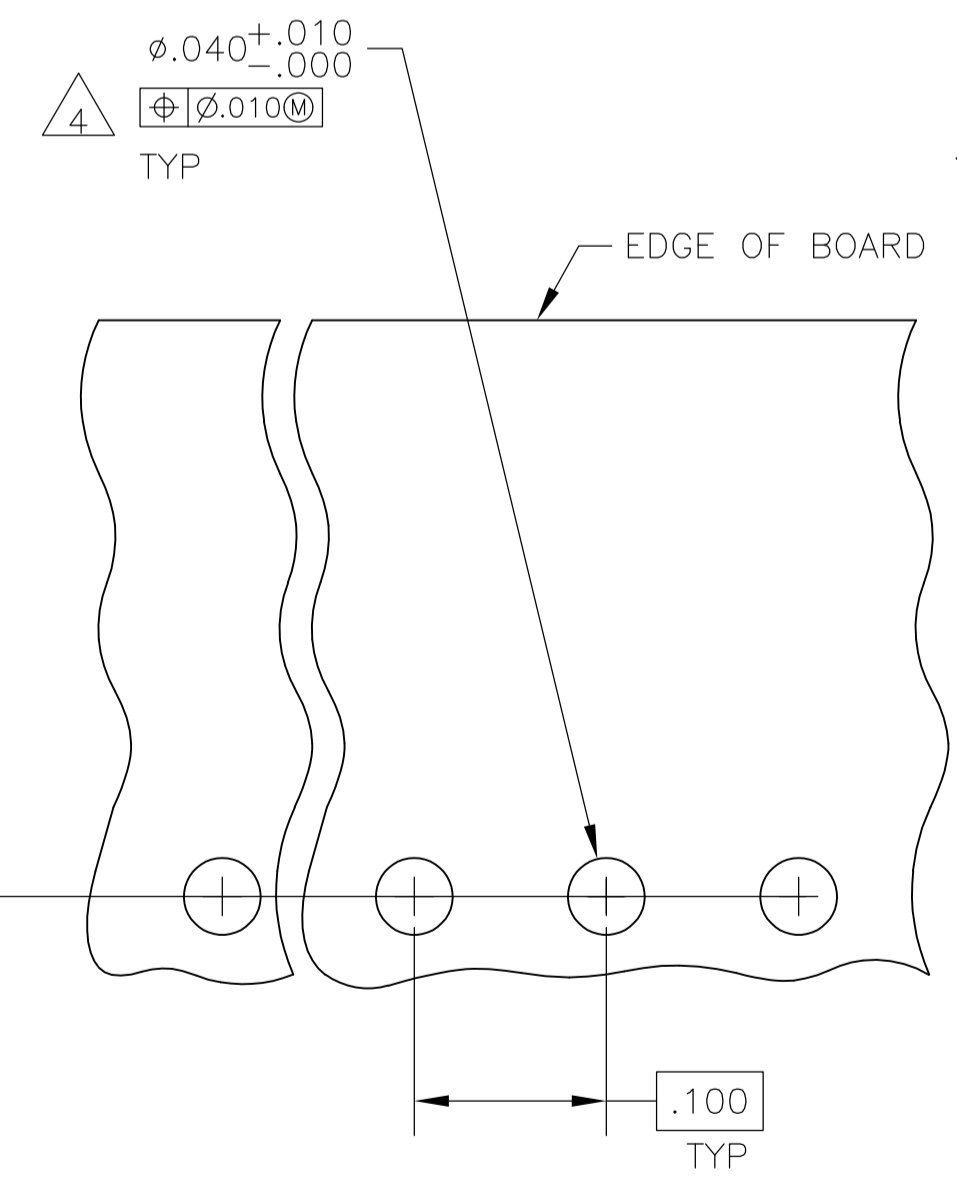
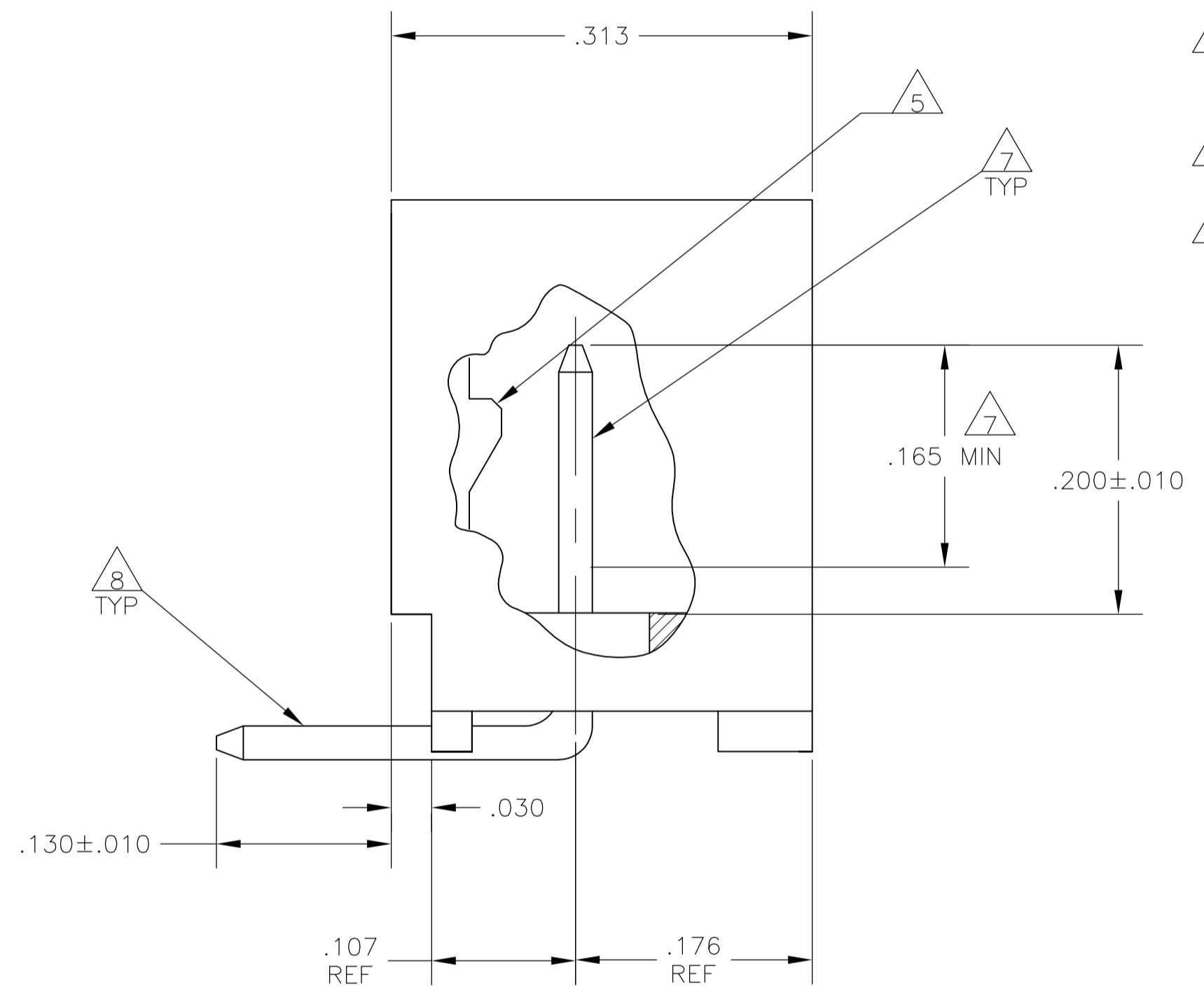
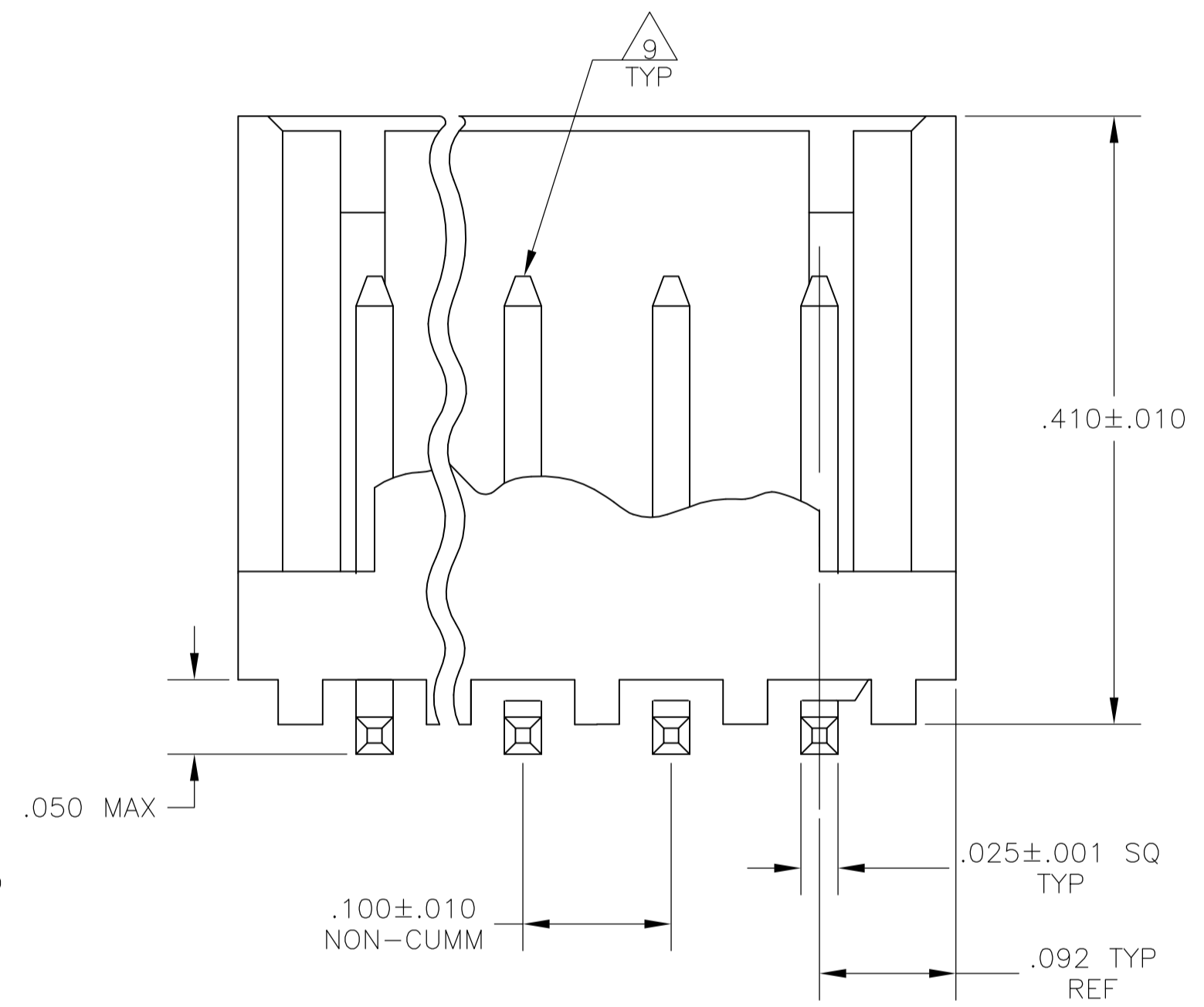

RECOMMENDED MOUNTING HOLE PATTERN FOR .063 THK PRINTED CIRCUIT BOARD

INCHES	MILLIMETERS	INCHES	MILLIMETERS
.050	1.27	-	-
.040	1.02	.410	10.41
.035	0.89	.313	7.95
.032	0.81	.300	7.62
.030	0.76	.176	4.47
.025	0.64	.165	4.19
.010	0.25	.140	3.56
.005	0.13	.130	3.30
.001	0.03	.107	2.72
.0000500	0.00127	.100	2.54
.0000300	0.00076	.092	2.34
.000	0.00	.063	1.60
IN	MM	IN	MM

CONVERSION TABLE

REV	DESCRIPTION	DATE	BY	CHK	APPV
1	SUPERSEDED BY 3-644489-4	1.484	37.69	14	3-644489-4
2	SUPERSEDED BY 3-644489-3	1.384	35.15	13	3-644489-3
3	SUPERSEDED BY 3-644489-2	1.284	32.61	12	3-644489-2
4	SUPERSEDED BY 3-644489-1	1.184	30.07	11	3-644489-1
5	SUPERSEDED BY 3-644489-0	1.084	27.53	10	3-644489-0
6	SUPERSEDED BY 2-644489-9	.984	24.99	9	2-644489-9
7	SUPERSEDED BY 2-644489-8	.884	22.45	8	2-644489-8
8	SUPERSEDED BY 2-644489-7	.784	19.91	7	2-644489-7
9	SUPERSEDED BY 2-644489-6	.684	17.37	6	2-644489-6
10	SUPERSEDED BY 2-644489-5	.584	14.83	5	2-644489-5
11	SUPERSEDED BY 2-644489-4	.484	12.29	4	2-644489-4
12	SUPERSEDED BY 2-644489-3	.384	9.75	3	2-644489-3
13	SUPERSEDED BY 2-644489-2	.284	7.21	2	2-644489-2

LEADFREE	IN	MM	NO OF POSITIONS	PART NUMBER
	L		HEADER ASSEMBLY	

THIS DRAWING IS A CONTROLLED DOCUMENT.

APPROVED BY: D. ROSSI, DATE: 29JUL02

TE Connectivity

MTA-100 SHROUDED HEADER ASSEMBLY, FRICTION LOCK, RIGHT ANGLE POST, .000030 GOLD

SIZE: A1, CAGE CODE: 00779, DRAWING NO: 644489

SCALE: 10:1, SHEET: 1 of 1, REV: L