

N-channel 30 V, 0.0027 Ω typ., 23 A STripFET™ H7 Power MOSFET plus monolithic Schottky in a PowerFLAT™ 3.3 x 3.3

Datasheet - production data

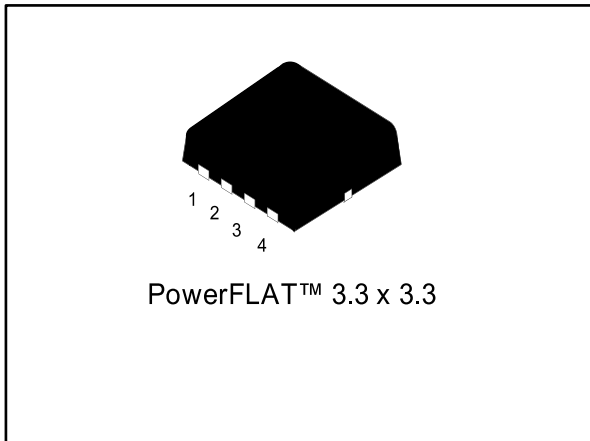

Figure 1: Internal schematic diagram

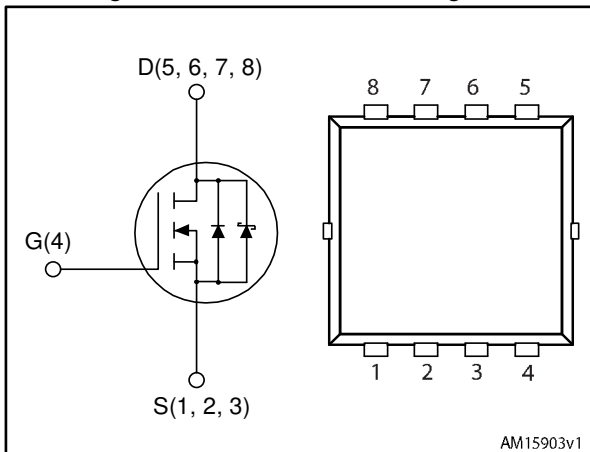

Table 1: Device summary

Order code	Marking	Package	Packing
STL23NS3LLH7	23NS3	PowerFLAT™ 3.3 x 3.3	Tape and reel

Features

Order code	V _{DS}	R _{DS(on)} max	I _D
STL23NS3LLH7	30 V	0.0037 Ω	23 A

- Very low on-resistance
- Very low Q_g
- High avalanche ruggedness
- Embedded Schottky diode

Applications

- Switching applications

Description

This N-channel Power MOSFET utilizes the STripFET H7 technology with a trench gate structure combined with extremely low on-resistance. The device also offers ultra-low capacitances for higher switching frequency operations.

Contents

1	Electrical ratings	3
2	Electrical characteristics	4
	2.1 Electrical characteristics (curves)	6
3	Test circuits	8
4	Package information	9
	4.1 PowerFlat 3.3 x 3.3 package information	10
5	Revision history	13

1 Electrical ratings

Table 2: Absolute maximum ratings

Symbol	Parameter	Value	Unit
V_{DS}	Drain-source voltage	30	V
V_{GS}	Gate-source voltage	± 20	V
$I_D^{(1)}$	Drain current (continuous) at $T_{pcb} = 25\text{ }^\circ\text{C}$	23	A
$I_D^{(1)}$	Drain current (continuous) at $T_{pcb} = 100\text{ }^\circ\text{C}$	14.3	A
$I_{DM}^{(1)(2)}$	Drain current (pulsed)	92	A
$I_D^{(3)}$	Drain current (continuous) at $T_C = 25\text{ }^\circ\text{C}$	92	A
$I_D^{(3)}$	Drain current (continuous) at $T_C = 100\text{ }^\circ\text{C}$	57.5	A
$I_{DM}^{(2)(3)}$	Drain current (pulsed)	368	A
$P_{TOT}^{(1)}$	Total dissipation at $T_C = 25\text{ }^\circ\text{C}$	50	W
$P_{TOT}^{(3)}$	Total dissipation at $T_{pcb} = 25\text{ }^\circ\text{C}$	2.9	W
T_{stg}	Storage temperature	-55 to 150	$^\circ\text{C}$
T_j	Operating junction temperature		

Notes:

⁽¹⁾This value is rated according to R_{thj-c} .

⁽²⁾Pulse width limited by safe operating area.

⁽³⁾This value is rated according to $R_{thj-pcb}$.

Table 3: Thermal data

Symbol	Parameter	Value	Unit
$R_{thj-pcb}^{(1)}$	Thermal resistance junction-pcb max	42.8	$^\circ\text{C/W}$
$R_{thj-case}$	Thermal resistance junction-case max	2.5	$^\circ\text{C/W}$

Notes:

⁽¹⁾When mounted on FR-4 board of 1 inch², 2oz Cu, $t < 10$ sec.

2 Electrical characteristics

($T_C = 25\text{ }^\circ\text{C}$ unless otherwise specified)

Table 4: On /off states

Symbol	Parameter	Test conditions	Min.	Typ.	Max.	Unit
$V_{(BR)DSS}$	Drain-source breakdown voltage	$I_D = 1\text{ mA}$, $V_{GS} = 0\text{ V}$	30			V
I_{DSS}	Zero gate voltage drain current	$V_{GS} = 0\text{ V}$ $V_{DS} = 24\text{ V}$			500	μA
I_{GSS}	Gate-body leakage current	$V_{GS} = \pm 20\text{ V}$, $V_{DS} = 0\text{ V}$			± 100	nA
$V_{GS(th)}$	Gate threshold voltage	$V_{DS} = V_{GS}$, $I_D = 1\text{ mA}$	1.2		2.3	V
$R_{DS(on)}$	Static drain-source on-resistance	$V_{GS} = 10\text{ V}$, $I_D = 11.5\text{ A}$		0.0027	0.0037	Ω
		$V_{GS} = 4.5\text{ V}$, $I_D = 11.5\text{ A}$		0.004	0.005	Ω

Table 5: Dynamic

Symbol	Parameter	Test conditions	Min.	Typ.	Max.	Unit
C_{iss}	Input capacitance	$V_{DS} = 15\text{ V}$, $f = 1\text{ MHz}$, $V_{GS} = 0\text{ V}$	-	2100	-	pF
C_{oss}	Output capacitance		-	850	-	pF
C_{rss}	Reverse transfer capacitance		-	60	-	pF
Q_g	Total gate charge	$V_{DD} = 10\text{ V}$, $I_D = 23\text{ A}$, $V_{GS} = 4.5\text{ V}$ (see Figure 13: "Gate charge test circuit")	-	13.7	-	nC
Q_{gs}	Gate-source charge		-	7.5	-	nC
Q_{gd}	Gate-drain charge		-	3.3	-	nC

Table 6: Switching times

Symbol	Parameter	Test conditions	Min.	Typ.	Max.	Unit
$t_{d(on)}$	Turn-on delay time	$V_{DD} = 15\text{ V}$, $I_D = 11.5\text{ A}$, $R_G = 3\text{ }\Omega$, $V_{GS} = 4.5\text{ V}$	-	10	-	ns
t_r	Rise time		-	33	-	ns
$t_{d(off)}$	Turn-off delay time		-	22	-	ns
t_f	Fall time		-	7.5	-	ns

Table 7: Source drain diode

Symbol	Parameter	Test conditions	Min.	Typ.	Max.	Unit
$V_{SD}^{(1)}$	Forward on voltage	$I_{SD} = 2 \text{ A}$, $V_{GS} = 0$	-	0.4	0.7	V
t_{rr}	Reverse recovery time	$I_{SD} = 2 \text{ A}$, $di/dt = 100 \text{ A}/\mu\text{s}$ $V_{GS} = 0 \text{ V}$	-	31.2		ns
Q_{rr}	Reverse recovery charge		-	18.7		nC
I_{RRM}	Reverse recovery current		-	1.2		A

Notes:

⁽¹⁾Pulsed: pulse duration = 300 μs , duty cycle 1.5%.

2.1 Electrical characteristics (curves)

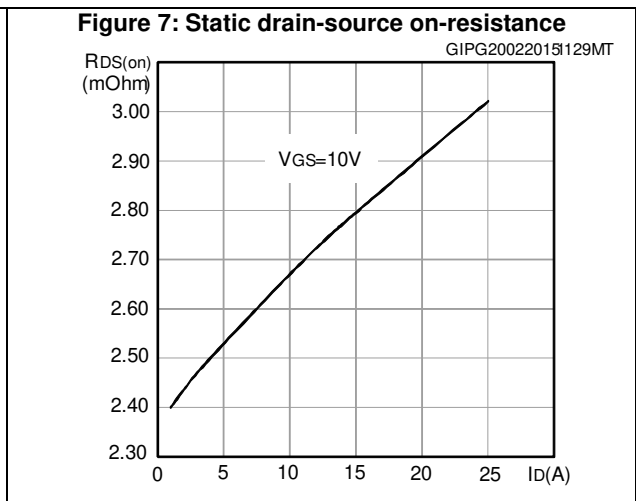
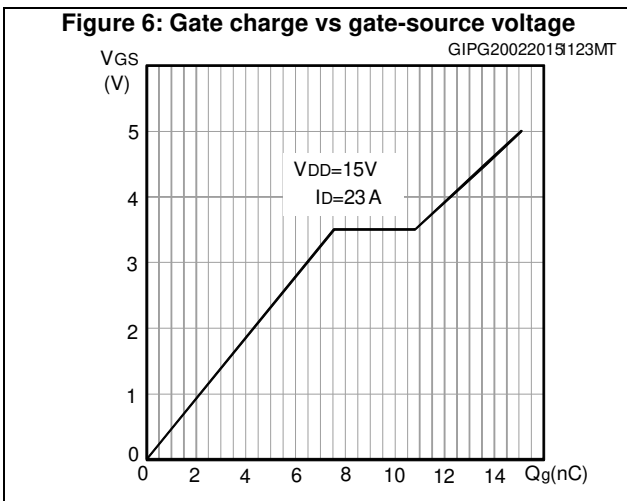
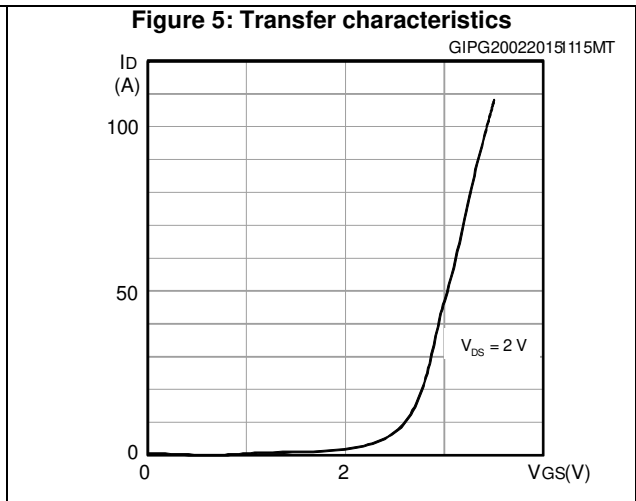
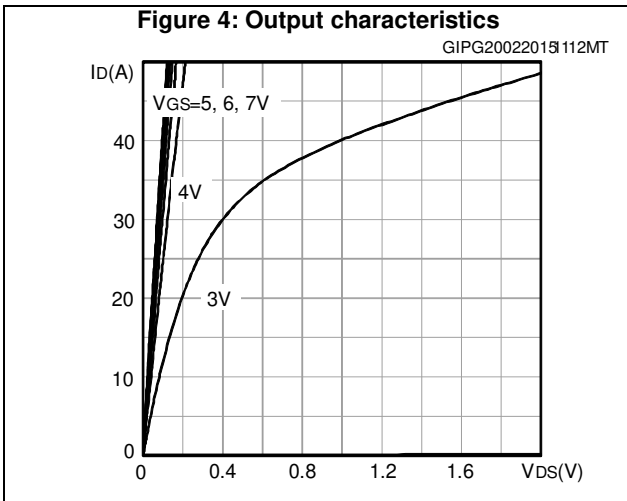
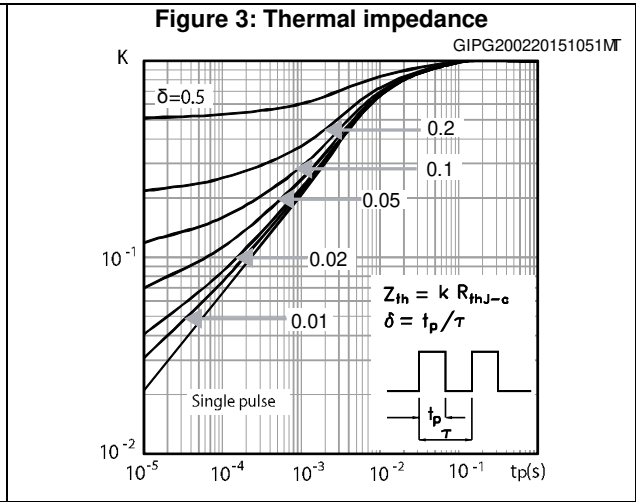
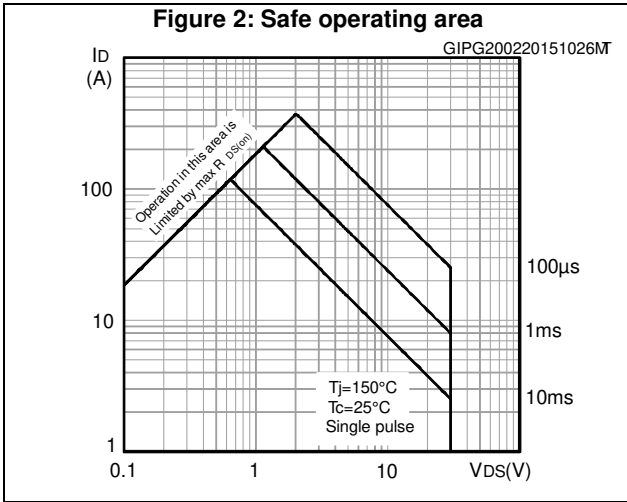

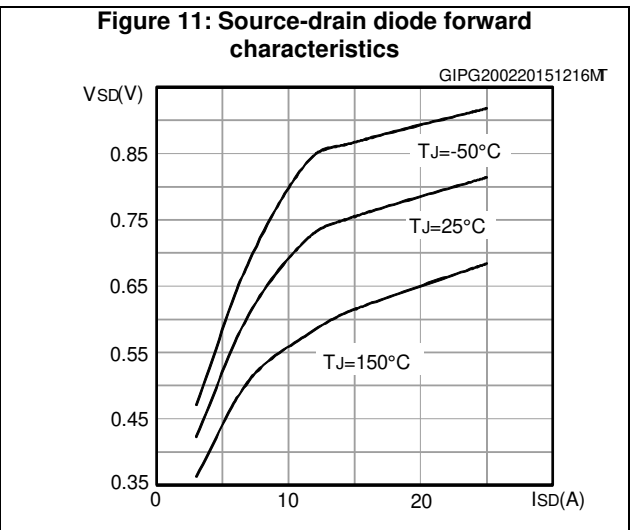
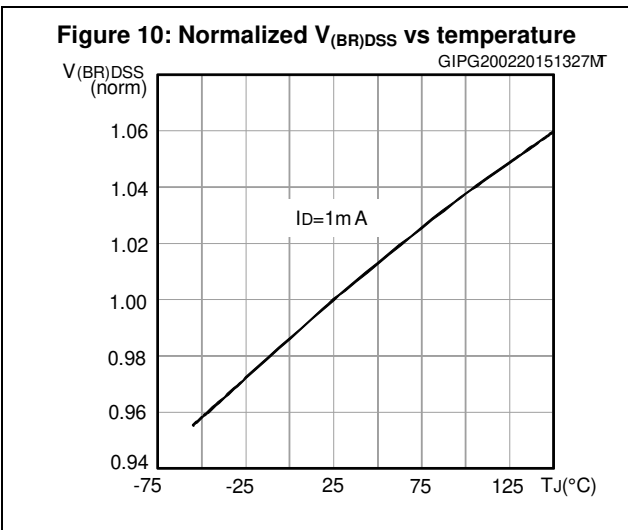
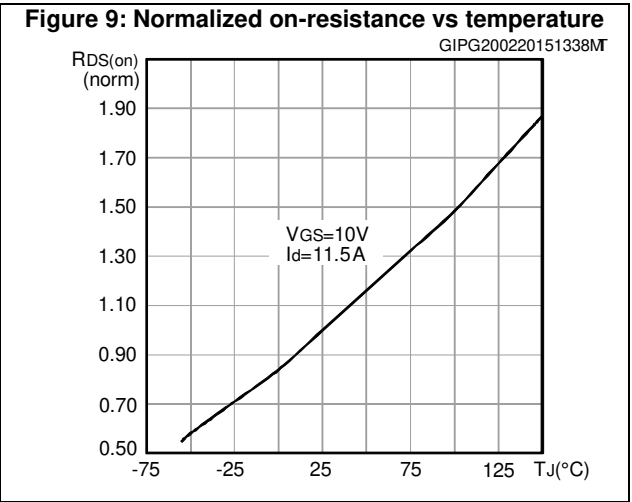
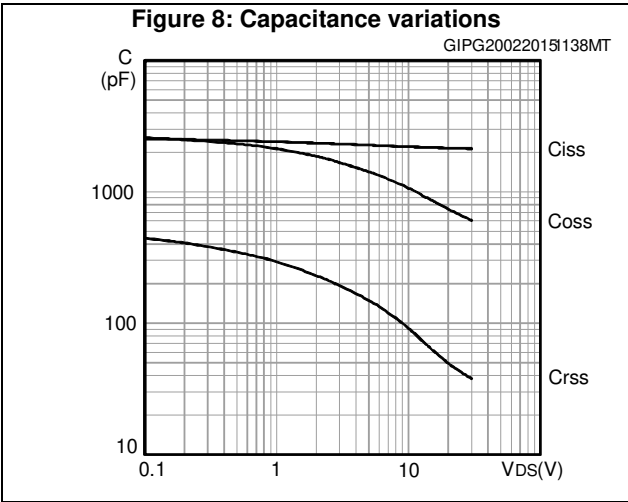

3 Test circuits

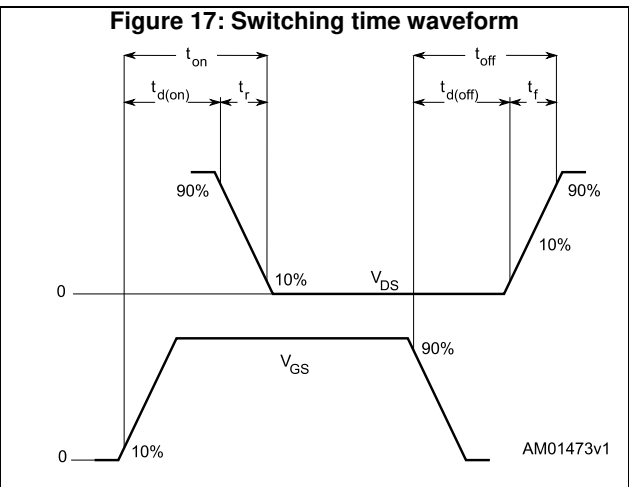
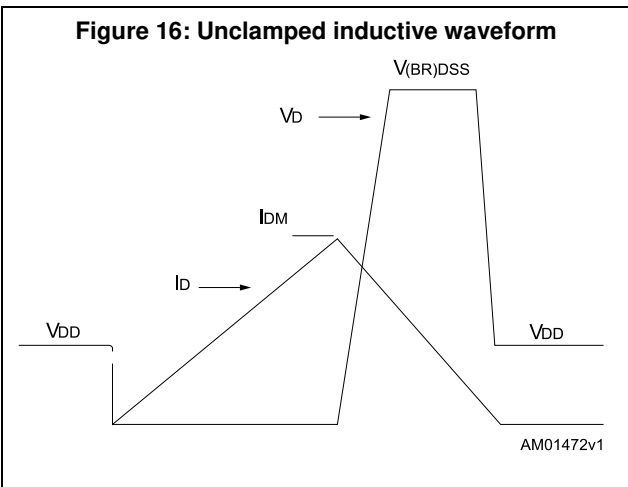
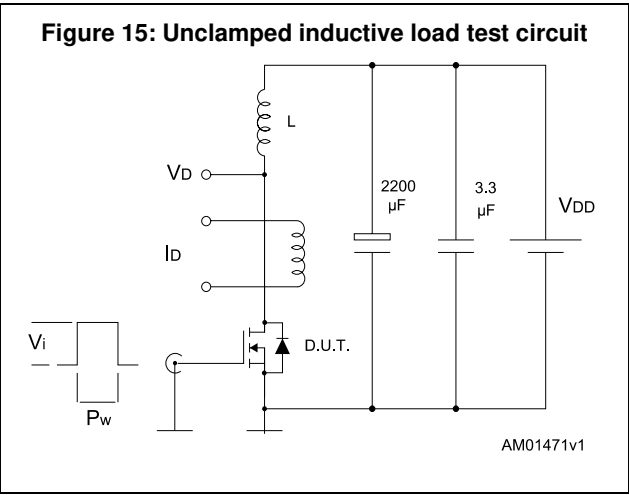
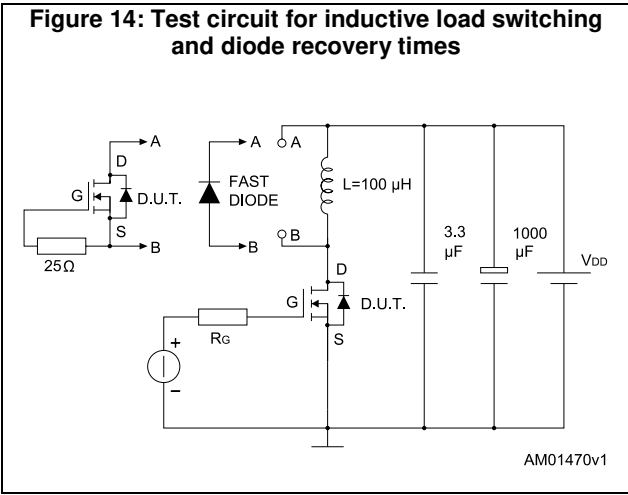
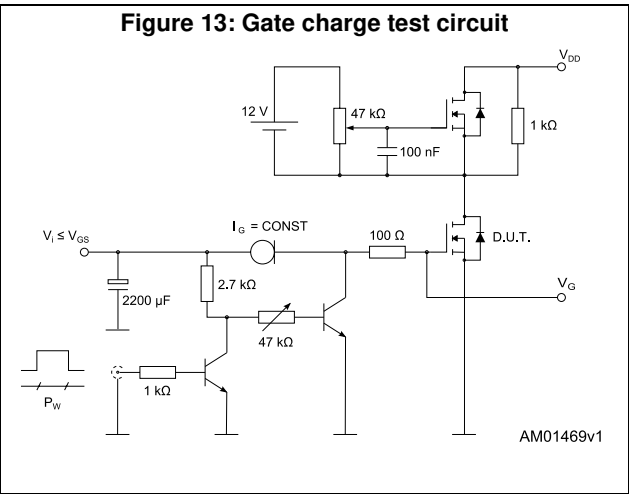
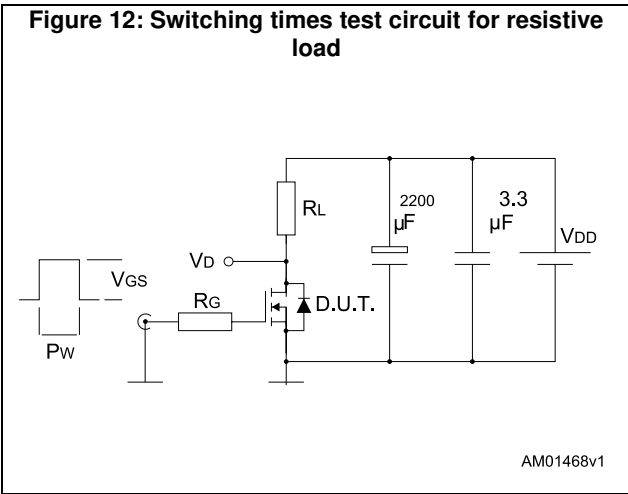

4 Package information

In order to meet environmental requirements, ST offers these devices in different grades of ECOPACK[®] packages, depending on their level of environmental compliance. ECOPACK[®] specifications, grade definitions and product status are available at: www.st.com. ECOPACK[®] is an ST trademark.

4.1 PowerFlat 3.3 x 3.3 package information

Figure 18: PowerFLAT™ 3.3 x 3.3 package outline

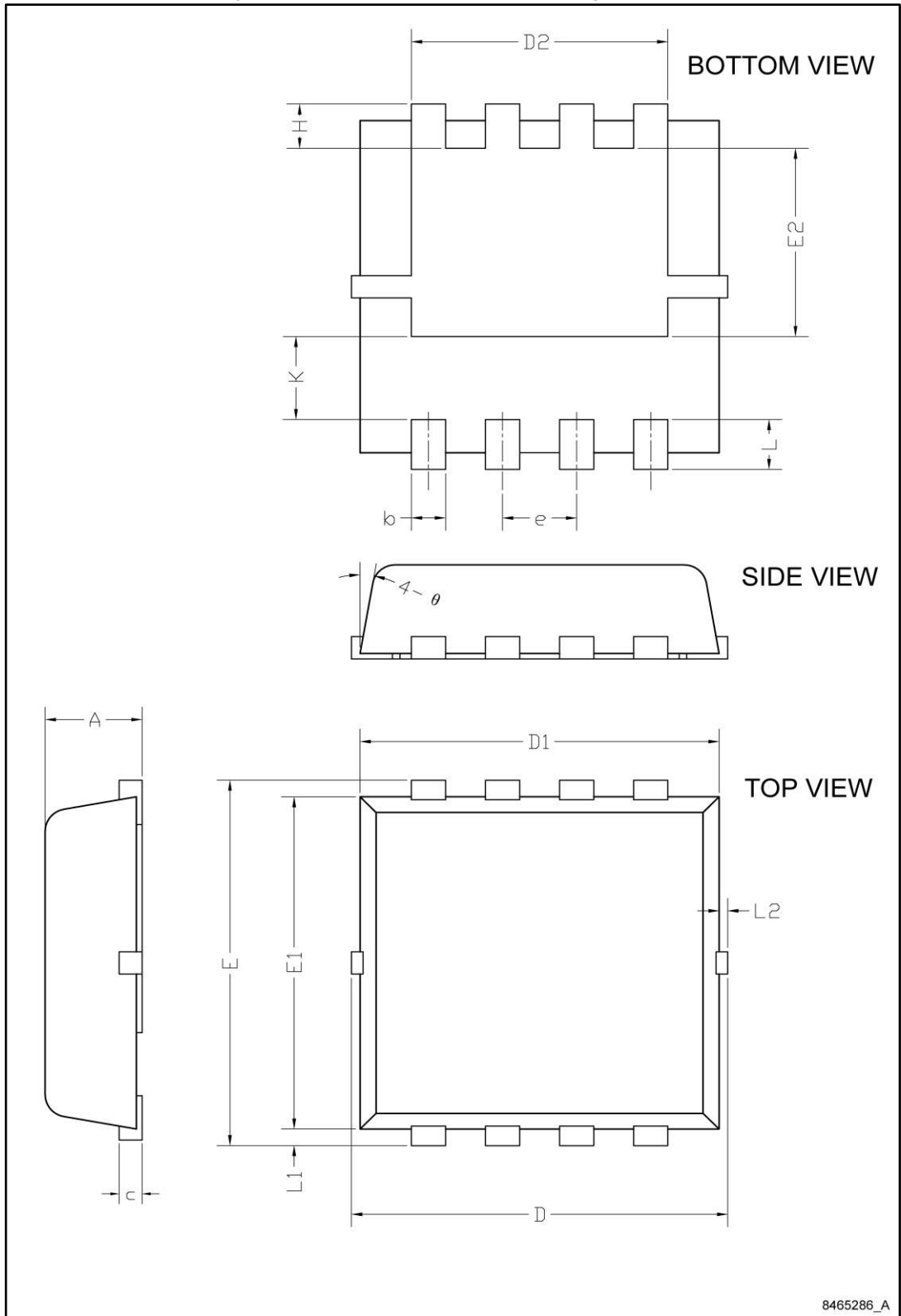
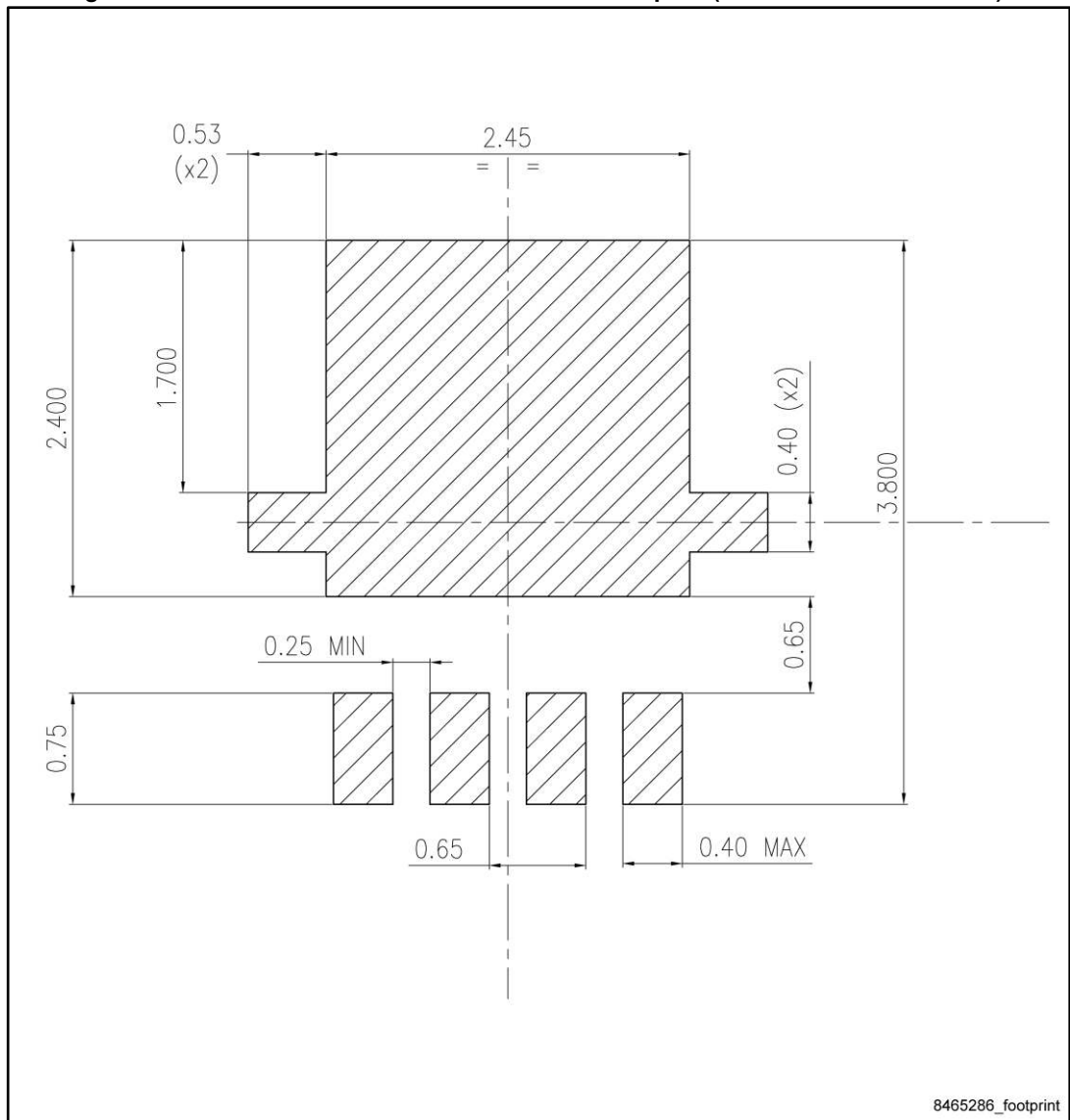

Table 8: PowerFLAT™ 3.3 x 3.3 mechanical data

Dim.	mm		
	Min.	Typ.	Max.
A	0.70	0.80	0.90
b	0.25	0.30	0.39
c	0.14	0.15	0.20
D	3.10	3.30	3.50
D1	3.05	3.15	3.25
D2	2.15	2.25	2.35
e	0.55	0.65	0.75
E	3.10	3.30	3.50
E1	2.90	3.00	3.10
E2	1.60	1.70	1.80
H	0.25	0.40	0.55
K	0.65	0.75	0.85
L	0.30	0.45	0.60
L1	0.05	0.15	0.25
L2			0.15
θ	8°	10°	12°

Figure 19: PowerFLAT™ 3.3 x 3.3 recommended footprint (dimension in millimeters)



5 Revision history

Table 9: Document revision history

Date	Revision	Changes
31-Jul-2013	1	First release.
27-Mar-2015	2	Updated title and features in cover page. Updated <i>Table 2: "Absolute maximum ratings"</i> , <i>Table 4: "On /off states"</i> and <i>Table 7: "Source drain diode"</i> . Added <i>Section 2.1: "Electrical characteristics (curves)"</i> . Minor text changes.
07-May-2015	3	Document status promoted from preliminary data to production data. Minor text changes.

IMPORTANT NOTICE – PLEASE READ CAREFULLY

STMicroelectronics NV and its subsidiaries ("ST") reserve the right to make changes, corrections, enhancements, modifications, and improvements to ST products and/or to this document at any time without notice. Purchasers should obtain the latest relevant information on ST products before placing orders. ST products are sold pursuant to ST's terms and conditions of sale in place at the time of order acknowledgement.

Purchasers are solely responsible for the choice, selection, and use of ST products and ST assumes no liability for application assistance or the design of Purchasers' products.

No license, express or implied, to any intellectual property right is granted by ST herein.

Resale of ST products with provisions different from the information set forth herein shall void any warranty granted by ST for such product.

ST and the ST logo are trademarks of ST. All other product or service names are the property of their respective owners.

Information in this document supersedes and replaces information previously supplied in any prior versions of this document.

© 2015 STMicroelectronics – All rights reserved